



University of  
Massachusetts  
Amherst

## Varied Applications of Work Zone Safety Analysis through the Investigation of Crash Data, Design, and Field Studies

Item Type	Thesis (Open Access)
Authors	Swansen, Erica
DOI	<a href="https://doi.org/10.7275/2406128">10.7275/2406128</a>
Download date	2026-06-08 23:22:12
Link to Item	<a href="https://hdl.handle.net/20.500.14394/47670">https://hdl.handle.net/20.500.14394/47670</a>

VARIED APPLICATIONS OF WORK ZONE SAFETY  
ANALYSIS THROUGH THE INVESTIGATION OF CRASH  
DATA, DESIGN, AND FIELD STUDIES

A Thesis Presented

by

ERICA LEE SWANSEN

Submitted to the Graduate School of the  
University of Massachusetts Amherst in partial fulfillment  
of the requirements for the degree of

MASTER OF SCIENCE IN CIVIL ENGINEERING

February 2012

Department of Civil and Environmental Engineering  
Transportation Engineering

© Copyright by Erica Lee Swansen 2012

All Rights Reserved

VARIED APPLICATIONS OF WORK ZONE SAFETY  
ANALYSIS THROUGH THE INVESTIGATION OF CRASH  
DATA, DESIGN, AND FIELD STUDIES

A Thesis Presented

By

ERICA LEE SWANSEN

Approved as to style and content by:

---

Michael Knodler, Chair

---

John Collura, Member

---

Richard Palmer, Department Head  
Department of Civil & Environmental Engineering

## ACKNOWLEDGMENTS

There are many people who have provided wisdom, guidance, and support in the completion of my research. Without their help and support, this long road would have seemed much longer. I am indebted to my boyfriend, Daniel Strang, who listened to my ideas, and sometimes complaints, while providing encouragement and love. In addition, my parents also deserve special thanks for their love and support through almost 20 years of schooling.

I would like to thank my advisor, Dr. Michael Knodler and committee member, Dr. John Collura for their help and knowledge throughout my time at UMass. I would also like to express my gratitude to Dr. Daniel Dulaski, who introduced me to the field of transportation and the opportunities of graduate research.

Thanks are warranted for Jennifer Kennedy for her patience in explaining the UMass Safety Data Warehouse and querying any and all data I needed, even with technical difficulties. I would like to extend this thanks to Robin Riessman who has a wealth of knowledge regarding crash reporting and commercial motor vehicles.

I am appreciative of the students who took the time to collect data, help me with narrative searches, and read and revise my papers. They included Cole Fitzpatrick, Keith Wenners, Manuel Pires, Ian McKinnon, Yue Tang, Evan Walsh, Jeffrey Young, Joseph Tyros and Samson Zhilyaev. Finally, I'd like to thank all of my colleagues at UMass who made this last year and a half one of the best I've had.

## ABSTRACT

### VARIED APPLICATIONS OF WORK ZONE SAFETY ANALYSIS THROUGH THE INVESTIGATION OF CRASH DATA, DESIGN, AND FIELD STUDIES

February 2012

ERICA LEE SWANSEN,

B.S.C.E., NORTHEASTERN UNIVERSITY

M.S.C.E., UNIVERSITY OF MASSACHUSETTS AMHERST

Directed by: Professor Michael A. Knodler Jr.

Work zone crashes and fatalities have been decreasing since 1994. Yet, according to Fatality Analysis Reporting System, 667 people were killed in highway work zone crashes in 2009. As the United States' infrastructure ages and new roads and highways are constructed less frequently, the need for repairs and alterations to the nation's roadways is continually increasing. This growth ensures that work zones will be a vital piece of design focus in the near future. In order to continue the decreasing trend in work zone crashes, and reduce the still significant number of work zone fatalities, work zones need to continually be examined to identify opportunities for improved safety.

This research explored the relationship between work zone related crashes and work zone design and setup. More specifically, existing literature and current standards, compiled with crash report form data in the UMass Safety Data Warehouse and field observations in Massachusetts were integrated to determine the causes and remedies for work zone related crashes. The research examined three critical areas: 1) causation of work zone related crashes in contrast to non-work zone related crashes along with

variations of citations as a result of work zone crashes; 2) variations of the work zone definition and the impact on work zone involvement and 3) analysis of conflict and event studies for small scale work zones to develop a methodology using surrogate measures to identify potential countermeasures leading to improved work zone safety. The results are expected to advance the current state of knowledge with regards to work zone design and setup, resulting in recommended actions for improved work zone analysis and design strategies.

# TABLE OF CONTENTS

	Page
ACKNOWLEDGMENTS .....	iv
ABSTRACT .....	v
LIST OF TABLES .....	xi
LIST OF FIGURES .....	xii
CHAPTER	
1 INTRODUCTION .....	1
1.1 Problem Statement .....	3
1.1.1 Crash Data Analysis.....	3
1.1.2 Work Zone Definition.....	5
1.1.3 Small Scale Work Zones.....	6
1.2 Research Goals And Objectives.....	6
1.3 Scope .....	9
2 BACKGROUND .....	11
2.1 Defining A Work Zone.....	12
2.2 Defining A Work Zone Crash.....	13
2.3 Work Zone Crash Analysis.....	14
2.4 CMV Crashes in Work Zones.....	16
2.5 Citation Data Analysis.....	20
2.6 Work Zone Design And Layout.....	21
2.6.1 Initial Design .....	21
2.6.2 Work Zone Crash Mitigation .....	24
2.6.3 Conflict and Event Studies.....	25
3 METHODOLOGY .....	26
3.1 Task 1: Literature Review .....	27
3.2 Task 2: Crash and Citation Data Analysis And Assessment .....	27
3.2.1 Crash Data Analysis.....	28
3.2.1.1 UMass Safety Data Warehouse.....	28
3.2.1.2 Crash Data Characteristics Analyses.....	31

3.2.2 Commercial Motor Vehicle Data Analysis .....	32
3.2.2.1 SAFETYNET .....	33
3.2.2.2 Massachusetts Commercial Vehicle Crash Data Tool .....	35
3.2.2.3 CMV Data Analysis .....	36
3.2.3 Citation Analysis .....	37
3.2.4 Crash and Citation Data Analysis Results .....	40
3.3 Task 3: Crash Narrative Analysis .....	40
3.3.1 Double Blind Narrative Search .....	42
3.3.2 Key Work Narrative Search .....	43
3.3.3 Narrative Search For Data Analysis Validation .....	44
3.3.4 Narrative Search Results .....	45
3.4 Task 4: Field Observations – Conflict and Event Study .....	45
3.4.1 Determination of Observations and Work Zones .....	46
3.4.2 Initial Work Zone Observation.....	46
3.4.3 Creation of Conflict and Event Study.....	47
3.4.4 Performance of Conflict and Event Study .....	48
3.4.5 Analysis of Results .....	48
3.5 Task 5: Documentation of Findings .....	49
4 RESULTS .....	50
4.1 Crash Data Analysis .....	50
4.1.1 Preliminary Crash Data Analysis .....	51
4.1.2 General Crash Data Analysis .....	52
4.1.2.1 Crash Level Analysis.....	53
4.1.2.1 VEHICLE LEVEL CHARACTERISTICS .....	59
4.1.3 CMV Specific Analysis .....	63
4.1.3.1 General CMV Crash Data.....	63
4.1.3.2 CRASH LEVEL CMV DATA .....	64
4.1.3.3 Vehicle Level CMV Crash Data Analysis.....	65
4.1.4 Citation Data Analysis .....	68

4.1.4.1	Generalized Work Zone Citation Analysis .....	68
4.1.4.2	Citation Rankings .....	70
4.1.4.3	General Crash and Citation Data.....	72
4.1.4.3.1	Time .....	72
4.1.4.3.2	Alcohol Related Citations .....	73
4.1.1.3.3	Injuries.....	74
4.1.4.4	Work Zone and Non-Work Zone Citation Analysis by Selected Event Related Variables .....	75
4.1.4.4.1	Vehicle Action Prior to Crash .....	77
4.1.4.4.2	First Harmful Event Location.....	77
4.1.4.5	Driver Contributing Code .....	78
4.1.5	Crash Data Conclusion of Results .....	80
4.2	Narrative Search.....	81
4.2.1	Double Blind Narrative Search .....	81
4.2.2	Key Word Narrative Search .....	84
4.3	Conflict And Event Studies .....	87
4.3.1	Traffic Infractions .....	98
4.3.2	Speed Related Conflicts And Events .....	98
4.3.3	Merge Related Conflicts And Events .....	98
4.3.4	Equipment Related Conflicts And Events.....	99
4.3.5	Setup Related Conflicts And Events.....	99
4.3.6	Age Related Conflicts And Events .....	100
4.3.7	Other Conflicts And Events .....	100
4.3.8	Serious Conflicts And Events.....	100
4.3.9	Conflict and Event Results Summary .....	101
5	CONCLUSIONS AND RECOMMENDATIONS .....	102
5.1	Data Analysis .....	102
5.1.1	Crash Analysis .....	103
5.1.2	CMV Specific Analysis .....	106
5.1.3	Citation Analysis .....	107
5.1.4	Potential Data Inaccuracies .....	111
5.2	Narrative Search Analysis .....	112

5.2.1 Random Sample Search .....	112
5.2.2 Narrative Key Word Search .....	113
5.2.3 Commonly Mislabeled Work Zone Narratives .....	115
5.2.4 Summary Of Narrative Search Results .....	116
5.2.5 Challenges With Narrative Searches .....	116
5.3 Conflict And Event Studies .....	117
5.4 Further Research .....	119
APPENDICES.....	121
A: AMERICAN NATIONAL STANDARD MANUAL ON CLASSIFICATION OF MOTOR VEHICLE TRAFFIC DEFINITIONS .....	122
B: MASSACHUSETTS CRASH REPORT FORM .....	128
C: NARRATIVE SEARCH WORKSHEET .....	129
D: CONFLICT AND EVENT WORKSHEET .....	133
REFERENCES.....	135

## LIST OF TABLES

Table	Page
1 Summary of CMV Crash and Fatality Involvement .....	19
2 Crash Data to be Analyzed .....	32
3 Chosen CMV Fields For Analysis .....	37
4 Injuries Resulting From Work Zone Related Crashes .....	51
5 Generalized Crash Data Breakdown .....	53
6 Crash Variables With P-Value .....	54
7 Crash Level Analyses .....	55
8 Vehicle Level Crash Analyses .....	60
9 General CMV Crash Data .....	63
10 Crash Level CMV Data Analyses .....	65
11 Vehicle Level CMV Crash Analyses .....	66
12 Work Zone And Non-Work Zone Related Crash And Citation Basic Analysis .....	69
13 Citation Analyses By General Crash Variables For Work Zone Versus Non-Work Zone Crashes .....	70
14 Citations For Work Zone And Non-Work Zone Crashes Sorted By Time .....	73
15 Citation Analysis By Event Related Variables For Work Zone Versus Non- Work Zone Crashes .....	76
16 Citation Analyses By Driver Contributing Code For Work Zone Versus Non-Work Zone Crashes .....	80
17 Double Blind Narrative Search Results .....	83
18 Discriminating Power Of Work Zone Related Words .....	84
19 Key Words In Narrative Search .....	87
20 Work Zone Descriptions .....	88
21 Roadway Location Characteristics Matrix .....	93
22 Work Zone Specific Characteristics Matrix .....	94
23 Observed Conflicts And Events .....	95

## LIST OF FIGURES

Figure	Page
1 Relationship of objectives and tasks. ....	26
2 UMass Safety Data Warehouse. ....	29
3 Massachusetts police crash report form. ....	30
4 Data flow for the UMass Safety Data Warehouse. ....	31
5 Truck and bus information in the police crash report form. ....	33
6 SAFETYNET information flow (32). ....	35
7 Narrative section of Massachusetts crash report form. ....	41
8 Work zone related narrative example . ....	44
9 Relationship between Task 4 and methodologic steps. ....	45
10 Average percentage of work zone related crashes by injury status for 2007-2009. ....	52
11 Percentages of crashes with single and multiple citations. ....	70
12 Percent of total citations that are alcohol or drug related. ....	74

# CHAPTER 1

## INTRODUCTION

In 2009, the American Society of Civil Engineers (ASCE) created a report card outlining the state of our Nation's infrastructure. The report card consisted of a list of graded infrastructure components. Out of 15 total categories, our nation's roadways received the lowest grade, a D-. In many instances, the roadways in the United States are reaching the end of their practical design lives and are in need of repair and rehabilitation. Yet at the same time, the amount of vehicle miles travelled (VMT) continues to increase. VMT is estimated to have been about 600 billion in the 1950s which increased to more than three trillion by 2006, and is expected to reach seven trillion by 2055. In contrast to this extreme increase in miles driven (79 percent in the last 20 years), the number of miles on the Interstate system has only increased by 15 percent in the last 50 years and five percent in the last 20 years (1, 2). From 1980 to 2005, truck VMT increased 105 percent whereas the highway lane-miles only increased 3.5 percent. In ten years, from 1994 to 2004, the ton miles of freight moved by truck increased 33 percent (3). The increasing traffic and VMT will continue to stress roads to their breaking point if nothing is done to remediate the effects. To combat the crumbling roadway system while maintaining operation, roadwork is constantly being performed. The Federal Highway Administration (FHWA) estimates that 20 percent of the National Highway System (NHS) is under repair during the construction season, resulting in over 3,000 work zones. About 12 billion VMT per year are spent travelling through work zones, and motorists encounter work zones one mile out of every 100 travelled (4).

In 2008, there were over 40,000 injuries resulting from crashes within a work zone (4). Although there was a 45 percent increase in work zone fatalities from 1996 to 2006, work zone safety has since been improving, and fatalities have decreased from 1,010 in 2006 to 835 in 2007, and further still to 720 in 2008. Also of concern, 235 of the 1,010 crashes in 2006 involved large trucks. The implication of those numbers is that a work zone injury occurs once every 13 minutes and a fatality once every ten hours (4).

As one would imagine, the nature of the work zone challenge has made all aspects of work zones the focus of many research efforts. Despite these efforts, the continued increase in the size and frequency of work zones coupled with the increasing demands for VMT requires added attention targeting key aspects of work zones. For example, the statistics cited above demonstrated that work zone safety is a serious issue which requires continued pursuit in order to maintain a downward trend in work zone crashes and fatalities. Researchers have been studying work zones to determine how and why crashes occur, and it has resulted in a multitude of studies, standards, and guidelines developed to address work zone issues. Research has also looked at where, when, and why crashes occur as well as identified countermeasures to reduce their negative impacts of the work zone related crashes. Despite this research, there remains a high degree of variability in crash reporting which creates discrepancies in crash data and the resulting analyses. Similarly, it is difficult to determine how to report crashes in the work zone, resulting in further inconsistencies.

This research examined the nature of work zone crashes using data from the Commonwealth of Massachusetts. An additional application of this research was to explore the feasibility of surrogate measures for assessing work zone safety. The results

from this study provide a better understanding of the variability of work zones and resulting crashes. This may prove useful for both law enforcement officers responsible for determining if a crash is work zone related, designers of work zones, and workers who layout work zone warnings, as well as many of the stakeholders in between.

## 1.1 Problem Statement

Much has been gained from the years of study and continual implementation of improved design procedures and technology when it comes to work zone safety. To that extent, much is known about typical work zone performance. For example, it is well understood that crashes often occur in work zones and can be attributed to a combination of factors including driver type, vehicle type and work zone layout, amongst others. Despite these efforts, work zone safety remains a topic of concern and when coupled with the increase in demand for work zones, there is a need for continued study. More specifically a need exists to build upon previous research in the development of a better understanding of work zones and their related crashes using both crash data and real world observations. Although the varied aspects necessitating work zones studies are significant and diverse, the research effort described herein targets three specific aspects of work zone safety as outlined below.

### 1.1.1 Crash Data Analysis

Work zones create a higher potential for crashes on roadways than normal roadway segments. The changes in roadway geometry, which are often unexpected and

much different than normal operating conditions, violate driver expectancy and create the opportunity for crashes. In an effort to make work zones safer for travelers, it is important to have an understanding of how and why these crashes occur. Factors in these crashes, such as time of day, weather, and driver behavior, when analyzed, can paint a picture of some of the causes of the crashes as well as what can be done to prevent them or lessen their severity.

Commercial motor vehicles (CMV) pose several more challenges in work zones than passenger vehicles. With a larger size, drivers who work extensive hours, and longer stopping and slowing distances, CMVs create a considerably higher amount of dangers in work zones than other vehicles do. Tighter lanes, smaller or closed shoulders, and abrupt lane changes cause issues for CMVs navigating the work zone. They are still overrepresented in work zone crashes despite efforts to decrease the chances of a crash. In addition, studies have shown that crashes involving CMVs and pedestrians, or for the purposes of this research, construction workers, more often result in injuries and fatalities. These CMV crashes still occur at an alarming rate. For example, on Tuesday, May 10, 2011 a speeding CMV in Pennsylvania ran into the back of a queue of vehicles resulting from a flagging operation. It resulted in a six vehicle chain reaction of rear end crashes and minor injuries. Understanding CMV crashes in work zones could lead to an improvement in work zone and CMV safety.

Citations written in work zone crashes can also provide a glimpse into the nature of work zone crashes. Police officers generally cite drivers in crashes for behaviors the officers believed the driver was doing wrong to have caused or influenced the crash. These citations have the potential to explain what went wrong when a crash occurs and

could lead to the identification of potential countermeasures for the behaviors that are most commonly seen as contributing to work zone crashes.

### 1.1.2 Work Zone Definition

A myriad of research efforts have focused on the crash statistics and safety analyses of work zones, yet there remains challenges associated with defining a work zone and determining the impact of the varied definition on subsequent crash analyses. Despite the fact that many crash report forms completed in the field by law enforcement officers responding to a crash have the work zone field marked, there remains a level of ambiguity with regards to whether the crash was in fact a work zone related crash. Further, there is added confusion as to whether a work zone crash should be identified as such if the work zone did not actually contribute to the crash itself. For example, how would one answer the work zone related field in the crash report form if a vehicle crashes into a work zone warning sign, or a queue resulting from the work zone a significant distance away the work activity zone? In addition, are there crashes without the work zone field marked in the crash report form that are, according to a specific work zone definition, actually work zone related? Developing a method for determining the accuracy of the work zone related field and verifying the field using a specific work zone definition can help make available work zone and non-work zone related data more accurate, and subsequently lead to improved analysis capabilities

### 1.1.3 Small Scale Work Zones

Within the range of work zone types, considerable time and effort has focused on large scale work zones. In many instances, these work zones are associated with high mobility roadways such as interstates or long term construction projects resulting in semi-permanent work zones. Less research, and subsequently less information, is available for small scale local work zones. These types of work zones are more often mobile, moving daily or even hourly through the roadway sections that are being repaired. In this regard, these work zones have the opportunity to violate driver expectancy more frequently than interstate work zones. The layout of these work zones needs to be examined to increase safety on local roadways where work zones are less regulated.

## 1.2 Research Goals And Objectives

As noted above, there is a continued need for applications of work zone safety analyses targeting specific aspects of the current approach to work zone safety. Based upon available research and literature, as well as potential benefits for a conflict and event study, an overall goal was developed. The overall goal of this research initiative was to identify and address issues related to work zone safety. Using both available crash data and direct field observation, work zone crashes were examined in detail along with work zone design and setup in an effort to improve critical aspects related to the understanding of work zone crashes to move towards improving the safety of work zones. Overall, the study was developed to provide a clearer sense of how and why crashes occur in a work zone, and what might be done to mitigate their occurrences. More

specifically, the intent was to provide a means by which to determine a relationship between the ways a work zone is set up, and how a work zone crash occurs.

The goal of this research approach, aimed at developing an improved understanding for multiple aspects of work zone safety analyses, directly led to the establishment of three research objectives. Each of the objectives, which are outlined below, correlates with a specific aspect of work zone safety identified as a critical area of need for research. The specific objectives are described further in the following:

1. *Characteristics can be determined for work zone crashes and those characteristics, can be used to determine the factors involved in and causes of work zone crashes.*

Using police crash report form data, citation data and SAFETYNET, work zone crashes, CMV specific work zone crashes, and citation data from work zone crashes were examined. The differences between work zone and non-work zone related crash data were analyzed to determine the number, type, and severity of the resulting work zone crashes. Using that analysis, this research establishes the widespread factors and causes of work zone crashes.

2. *A definition for a work zone can be found and the manipulation of that definition will result in a change in the characteristics and amounts of crashes that result in that work zone.*

This research examines and analyzes work zone crash data in the form of police reported crash report form narratives to determine the causes of work zone related crashes. A definition was established for work zone crashes. Using that definition of work zone crashes, the crash narratives were examined to determine the extent to which that definition changes the nature of work zone crashes.

3. *Using a conflict and event study, a methodology can be developed to identify work zones on secondary roads with a higher potential for crashes. This methodology can provide an opportunity to recognize the factors and characteristics of work zones. Measures can be taken, using the results of the study, to change the work zone layouts and reduce the amount and severity of the crashes. These changes could potentially be addressed in work design plans.*

A conflict and event study was created for use with small scale work zones on secondary roads. The work zones were categorized and characteristics of those work zones were observed and recorded. The results of the studies were compared to establish reoccurring conflicts and events for each as well as across all studied work zones. The results may be used to determine where small, easy changes can be made in work zones during setup or after, once specific problems are identified.

The remainder of this thesis explains the methods that were explored to attain the overarching goal and subsequent objectives set forth earlier and will describe the manner

by which the research objectives were accomplished. In continuation, the results will be laid out and conclusions and recommendations will be formed.

### 1.3 Scope

As previously noted, the research approach addressed three critical areas related to work zone safety: analyzing crash and citation data for work zones; quantifying the impact of varied work zone definitions; and determining surrogate measures of safety related to small scale work zones. Admittedly, there are many additional aspects of work zones warranting consideration; however, the scope of the research was limited simply to those listed above.

As is often the case with data analysis, the size and scope of research is directly limited by both the quality and availability of the data. This research effort was no exception. The scope was limited to the consideration of the available police reported crash and citation data, crash narratives and additional work zone data within the Commonwealth of Massachusetts. The data was directly accessed via the UMass Safety Data Warehouse (Warehouse), while field observations were also limited to locations within Massachusetts. The Warehouse data consisted of police crash report forms that were included in the data set from 2007 to 2009, as well as police issued citation data for the same period, representing the most recent available data at the time of the study. It also included improved CMV data from the SAFETYNET program. When researching work zone safety, there is a need to link work zone setups with their corresponding

effects on traffic operations. This research, however, was limited to describe safety analyses and did not consider the operational aspects of work zones.

Field observations were also a key portion of this research. Data was collected in the form of conflict and event studies in real world work zone setups. The scope of these observations was local (non-interstate) roadways primarily in Western Massachusetts and characterized by functional classification as well as layout. Drivers were not informed of the observations taking place and therefore behaved normally when driving through the work zone. Although large scale conflict studies could have been performed, the studies in this research were limited to Massachusetts during the summer and fall months with the number and duration of work zones determined based upon the experimental protocol and need for statistical testing.

## CHAPTER 2

### BACKGROUND

The overall goal of identifying and addressing issues in work zone safety along with the subsequent objectives involving the impacts of crash data and citation analysis, varied work zone definitions, and conflict and event studies of small scale work zones resulted from studying and evaluating work zone research. Throughout the years, state agencies, researchers, and other transportation professionals have been working together to improve work zone safety creating a multiplicity of resources that can be and are employed nationally to increase safety in work zones (5, 6, 7, 8, 9, 10, 11).

In recent years, work zone fatalities have been decreasing (4). However, in order to maintain that trend, several work zone features and situations need to be reexamined to provide engineers with a better understanding of why crashes occur. Literature has shown that work zones have higher crash rates than the same roadways under normal operating conditions. In 1965, a study of ten California work zones showed a 21.4 percent increase in crashes during construction than before (12). In Georgia, a 61 percent increase in crashes was seen for 207 studied work zones (12). In addition, about one out of every five fatalities in a work zone involves non-motorists (2). This is especially important on highways where the probability of a fatality for a pedestrian being struck by a vehicle traveling at 40 miles per hour is approximately 85 percent (9). The Rule on Work Zone Safety and Mobility (RWZSM) has devised three stages for work zone management: “conducting detailed project-level work zone impacts assessment during design,

managing work zone impacts during construction, and conducting work zone performance assessment on a regular basis (7).” Existing research has used these methods to assess work zone safety.

The sections below provide an overview of work zone related research and findings. The topics discussed are: defining a work zone; defining a work zone crash; work zone crash analyses; CMV crashes in work zones; citation analysis; and work zone design and layout, which includes initial design, work zone crash mitigation, and conflict and event studies.

## 2.1 Defining A Work Zone

One of the existing challenges with analysis of work zone crashes is the ambiguity that is present within the description of the work zone itself. This has been made apparent in the introduction, goal, and objectives of this research effort. The FHWA has been involved in many attempts to develop a standardized definition of a work zone. Adding to the complexity in the creation of a standard work zone definition is the mobile nature of many work zones. Defining a work zone using the queue is a challenge because queues resulting from work zones are constantly changing, which results in a dynamic work zone area (13). Using the “begin work zone” and “end of work zone” signs to define the work zone area is difficult as well. Many short term and mobile work zones do not use “end of work zone” signs and work zones often shift within a stretch of roadway in accordance with the type of work being completed, rendering the beginning and ending signs inadequate (13). A definition was created and added to the

American National Standard Manual on Classification of Motor Vehicle Traffic Accidents (ANSI) that said “a work zone is an area of trafficway with highway construction, maintenance, or utility-work activities...” (14). The definition then continued to describe specific work zone types and examples. The full definition can be found in Appendix A. The ANSI definition is used by many states, including Massachusetts. The FHWA, along with the National Highway Traffic Safety Administration (NHTSA), in the National Highway Work Zone Safety Program (NHWZSP), says that a national definition will be provided for a work zone and states will also be provided with the minimum information that needs to be collected to determine fatalities and injuries resulting from work zone crashes (8). This has not been completed yet though. The FHWA has also set up a national information exchange that promotes the conversation and cooperation between agencies, states, and researchers regarding improving work zone safety (8). These differences in work zone definitions create inconsistencies in work zone related crash reporting. A study completed by the Texas Transportation Institute (TTI) claimed that only 12 percent of accidents in work zones were actually work zone related (13).

## 2.2 Defining A Work Zone Crash

The goal and objectives set forth earlier have described the challenges of defining a work zone. Those same challenges present themselves when defining a crash within a work zone. Although the definition of a work zone would constantly change using the queue as the beginning of the definition of a work zone, the FHWA states that a work

zone crash should include crashes that occur due to work zone queues (13). The FHWA proposed that a work zone crash should include all crashes occurring inside the work zone as well as crashes outside the work zone that were caused by it (13). ANSI states that a work zone crash is “a traffic accident in which the first harmful event occurs within the boundaries of a work zone or an approach to or exit from a work zone...” (14). The full definition can be found in Appendix A.

The Massachusetts Department of Transportation (MassDOT) has encountered trouble, like many other state departments, when trying to establish whether a crash is work zone related or not. One specific instance of question is if a crash was work zone related when a driver distracted by an off-road construction site and subsequently crashed. Another specified challenge that MassDOT has encountered involves utilities in which there are no specific work zone setups. MassDOT has also encountered inconsistencies with the Fatality Analysis Reporting System (FARS) for fatal crash reporting. In 2009, the FARS data had nine work zone fatalities. Upon investigation, MassDOT determined that two of the nine crashes listed were not work zone related, while two other crashes listed as non-work zone related actually were.

### 2.3 Work Zone Crash Analysis

The first objective of this research, work zone crash data analysis relied heavily on previously attempted methods and results of work zone crash analyses. To reduce the number and severity of crashes within the work zone or related to the work zone, the nature of the crashes must be known. This includes the roads they occur on, the times

they occur, and the types of crashes that result. Many studies have looked at the temporal, location, and general crash variables associated with work zone crashes as compared to non-work zone crashes. The following paragraphs describe some of the basic findings of generated work zone crash data.

According to Akepati and Dissanayake, who examined five years of data from 2002-2006 for five states, a majority of work zone crashes occurred during daylight conditions, with no adverse weather conditions, and on dry road surface conditions (15). The majority of those work zones crashes were property damage only (PDO) crashes. In that five year period, 296 people died in work zones studied and 27.2 percent of the crashes resulted in an injury (15).

The most frequent types of work zone crashes are rear-end crashes that are caused by unexpected queuing (2). Akepati and Dissanayake found that a collision with other moving vehicles is one of the most predominant crashes with 73.3 percent of total work zone crashes (15). Out of the collisions with another vehicle, rear-end collisions (42.7 percent) were the most frequent type of crash in work zones followed by angle (14.4 percent) collisions. Results showed that drunken drivers were involved in nearly one-fourth (21.3 percent) of the work zone crashes (15). Garber and Zhao performed a study in Virginia examining work zone characteristics from 1996 to 1999 and found that 50 percent of work zone crashes were rear end crashes and 60 percent of crashes were PDO crashes (16).

In 1996, 55 percent of work zone fatalities occurred in rural areas (13). Garber and Zhao determined five different areas of a work zone: advance warning, transition, longitudinal barrier, activity, and termination (16). They found that about 70 percent of

the work zone crashes occurred in the activity zone (16). In Akepati and Dissanayake's study, their Iowa and Nebraska analyses found the majority of work zone crashes occurred in a lane-closure (37 percent) type of work zone (15). The highest proportion (47.6 percent) of crashes occurred in the activity area where the actual work was being performed. The highest proportion of work zone crashes (26.1 percent) also occurred where speed limits were 51 to 60 mph followed by 31 to 40 mph. Based on total crashes, a majority (30.4 percent) occurred at places where there was no traffic control within work zones, followed by work zones with the presence of traffic signals. Inattentive driving (21 percent) in work zones was the leading cause of crash occurrence, while following too close was responsible for 16.6 percent of total work zone crashes (15). Wang et al. determined the most common causes of work zone crashes are failure to stay in lane, reduce speed, and yield right of way (12).

## 2.4 CMV Crashes in Work Zones

The first objective of this research also concentrated on CMV crashes in work zones. A review of CMV research regarding involvement in work zones was required to have an understanding of what information existed and what needed to be improved upon. There are many discrepancies in the number of CMV related work zone crashes. FHWA claims, almost 30 percent of work zone crashes involve trucks. In 1996, 25 percent of the 719 fatalities in work zone crashes involved large trucks (13). According to FARS, only about 4.4 percent of fatal crashes involving large trucks were in a construction/maintenance zone (17). The University of Massachusetts Traffic Safety

Research Program (UMass Safe) performed a study in Massachusetts and discovered that CMVs have about twice as many crashes in work zones as other motor vehicles. In 2008, 3.8 percent of CMV crashes occurred in work zones and only 1.8 percent of non-CMV. There is also an overrepresentation of fatal as well as all injury level crashes involving CMVs. UMass Safe found that the manner of collision most common in crashes involving CMVs in work zones is rear end collisions followed by angle crashes (18).

CMVs are more likely to result in injuries or fatalities in work zones. A study in Kansas performed by Li and Bai found that trucks were involved in 42.4 percent of fatalities and 15.5 percent of injuries in work zones. That study also found that severe crashes involving heavy trucks were about three times more likely to result in a fatality (19). UMass Safe found the percentage of crashes in a work zone with a person injured are higher for crashes involving CMVs than crashes that did not involve CMVs (18). The analysis from the five states in Akepati and Dissanayake's study, mentioned earlier, found that 10.3 percent of work zone crashes involved heavy-duty vehicles (15). The following table, Table 1

Table 1 SUMMARY OF CMV CRASH AND FATALITY INVOLVEMENT, gives an overview of the CMV involvement in work zone crashes and fatalities as found in the literature.

**TABLE 1 Summary of CMV Crash and Fatality Involvement**

<b>Percent of work zone crashes that involve CMVs</b>	FHWA 30%	Akepati and Dissanayake 10.3%
<b>Percent of fatal crashes in work zones that involve CMVs</b>	What's a Work Zone 25%	Li and Bai 42.4%
<b>Percent of CMV fatalities that occur in work zones</b>	FARS 4.4%	UMass Safe 3.8%

Law enforcement officers' presence is another factor in considering CMV safety in work zones. A study completed for the Missouri Department of Transportation found a 32 percent reduction in the proportion of trucks exceeding the posted speed limit when an officer was present in a work zone in Illinois (20). The amount of trucks exceeding speeds deemed appropriate for the conditions also decreased by 32 percent (20). While reviewing crash history, a study from Iowa State University found that there was a significant reduction in work zone crashes when special enforcement was present. During a national survey, the Texas Transportation Institute (TTI) asked truck drivers if they would feel safer in work zones with stricter law enforcement; 49 percent said they would (21). About 60 percent of truck drivers claimed they would drive more carefully if there was increased law enforcement and they would be more likely to obey reduced speed limits. However, that same study found the presence of law enforcement does not have a statistically significant impact on the number of crashes (21).

## 2.5 Citation Data Analysis

Citations, coupled with police reported crash report form data provides a more complete picture of the nature of work zone crashes. Not only analyzing data such as driver, vehicle, and crash factors, but combining the data with citation information, provides the opportunity for a more complete understanding of why or how a crash in a work zone occurs. Police write citations for drivers they believe were at fault for some part of a crash. This provides researchers with a glimpse of not only the events of the crash, but the tasks the drivers were performing (i.e. speeding, drinking alcohol) that may have caused the crash.

Studies have previously used available citation information to determine relationships between chosen crash characteristics. The citations have helped provide insight into how often crashes can be expected to occur, which types of drivers are more at risk for crashes, and where the fault lies within the crashes. Comparing police issued citations with police reported fields in the crash report forms for work zone and non-work zone related crashes can bring to light the differences between the two types of crashes. An extensive examination of literature has not found any studies using citation information to analyze work zone crashes.

A study of Utah drivers, conducted by Vernon et al. between 1992 and 1996, used citation data as well as crash information to compare the rates of adverse driving events of drivers with or without medical conditions indicated on their licenses. The study found that, using citations as an indicator, the risk factors for adverse events for participants with medical problems were 5.83 times higher than the control group (22). Dulisse completed a study in 1997 using hospital information from two-vehicle crashes in Wisconsin in 1991 to determine the connection between driver age and the likelihood of receiving a citation as a result of a crash. Using the available information from Wisconsin Crash Outcomes Data Evaluation System (CODES) which links hospital discharge information with police crash reports, Dulisse was able to determine that the probability of receiving a citation for drivers in two-vehicle crashes is higher for 85+ drivers

than the rest of the population, suggesting that age-neutrality may not exist in ticketing (23). In 2001, McCartt et al. used self-reported data from teenagers in four states to examine the relationship between driving experience among newly licensed teen drivers and the risk of crash or citation. Teenagers had a high risk, with 23 percent of students reported receiving a citation not resulting from a crash and 33 percent received more than one citation.

## 2.6 Work Zone Design And Layout

In order to maintain a downward trend in work zone crashes, injuries, and fatalities, work zones design and organization needs to be examined and improved upon. The way a work zone is designed and then laid out has an impact in almost every aspect of work zone safety. Crashes are often a direct result of the organization of a work zone. This is the case for passenger vehicle and CMVs, as well as interstates and small scale work zones. The conflict and event studies that were performed as part of the third objective could be used to improve upon the design and layout of work zones. The studies and results were based on and subsequently had an effect on the initial design of as well as crash mitigation in work zones.

### 2.6.1 Initial Design

There are many national guidelines and standards for the design and layout of work zones and individual states also have specific requirements (5) (6) (8) (9) (10). The Manual on Uniform Traffic Control Devices (MUTCD) describes five different types of work zones: long term stationary, intermediate term stationary, short term stationary, short duration, and mobile and it provides standards, guidance, and recommendations for traffic control within a work zone (6). A study done by Ullman et al. used four different

work zone operation categories: lane and shoulder closure operations, flagging operations, mobile operations, and traffic control setup and removal operations. The study documented the sequences leading up to crashes in those work zones and found that in lane closure intrusions, 56 percent of crashes, were due to non-deliberate driver actions either from stopped traffic or an incorrect reaction to temporary traffic control. At mobile operations, 63 percent of the time, intrusions were due to the driver misjudging the work convoy they were approaching. In flagger operations intrusions, a higher amount of crashes was due to deliberate driver actions than non-deliberate (24).

According to the National Cooperative Highway Research Program (NCHRP) Report 581: Design of Construction Work Zones on High Speed Highways report, “repeated exposure to, as well as successful experience with, certain roadway configurations creates driver expectancies (9).” This means drivers respond to situations in ways they have done in the past that were successful. Work zones tend to violate driver expectancy and create a higher mental workload. NCHRP 581 states that “safety-critical and other important information should be clearly, conspicuously, and prominently presented to drivers (9).” Ullman et al. found that 38 percent of crashes in work zones were with work vehicles, and surprise and inattention were the major factors in the crashes (24).

Studies have shown that the placement and usage of work zone warning features has an impact on the speeds that are travelled through the area. A study of I-91 in Massachusetts, by Heaslip et al., found that variable message signs, the taper sight area, taper, and work zone areas all showed a significant decrease in mean traveler speeds, while static work zones signs did not. Heaslip et al. held a focus group regarding their

work zone study, in which drivers gave suggestions about the work zone setup of the I-91 location, many of which focused on providing better advanced warning to improve anticipation of the work zone (25).

There are several ideologies about varying speeds in work zones. According to the paper, *Work Zones That Work*, varying the speed as work conditions change result in increased credibility of speed limits, greater speed compliance, improved safety and improved compliance (2). Garber and Zhao claim that countermeasures that reduce speed variability will be effective in reducing work zone crashes (16). When choosing work zone design and operating speeds, designers need to be cautious to not violate driver expectancy with a simple speed change. NCHRP 581 claims that when there is a reduction of ten miles per hour, the drivers should be clearly notified. There should also be a forgiving roadside for the drivers if possible (9). The report suggested several strategies for improving work zone layouts to increase safety. These include but are not limited to detours, diversions, lane constrictions and the use of the shoulder. The report cautions against features in work zones that may pose problems, such as construction equipment, severe slopes and drop-offs, as well as certain guardrail configurations. NCHRP 581 also suggests using a benefit to cost ratio to decide which measures to take when designing the work zone (9).

A study by Finley suggested that when motorists see speed limit signs for work zones but do not see the work zone, their speed only decreases very slightly. The drivers only reduce their speed if they feel it is appropriate. Those feelings depend on the imposing nature of the work zone as well as enforcement presence. The study claimed that work zone conditions used to justify speed reductions are often inaccurately

perceived by motorists. High levels of non-compliance were also found to result when speed limits signs for work zones are left in place during non-working hours or after the work is complete. Finley suggests removing or covering work zone signs to maintain credibility (26).

### 2.6.2 Work Zone Crash Mitigation

Once a work zone is in place, it is important to be able to recognize hazards and be able to alleviate the negative effects on drivers and workers through redesign or mitigation of the hazards. NCHRP 500-17: A Guide for Reducing Work Zone Collisions provides strategies and countermeasures to improve safety in work zones. It uses a series of objectives and related strategies to provide for a safer working and driving environment (10). To provide proper protection for workers and drivers, the NCHRP 581 suggests factors and situations like duration of the construction activity, length of the hazard, adverse geometrics, and proximity of traffic to construction workers and equipment (9). According to the RWZSM, the most significant hazards for mobile and short duration maintenance zones are high speeds and inattentive motorists which result in rear-end crashes where vehicles enter the work area. The RWZSM asks designers to consider safety and mobility trends for work zones at the national or local level and then explore and promote characteristics that are associated with the positive trends. It also suggests the designers create remedies for poor safety trends (7). A simulator study by Antonuci et al. found that work zone devices were the second most likely targets involved in crashes. The study also found that there was a statistical difference in speeds between when a lane was closed and only a shoulder; when the lane was closed, the

vehicles swerved more for objects in the roadway. The factors that caused vehicles to decelerate the most were sign, barrel, or cone encroachment into the lane, a knocked over barrel, slow moving vehicles, or a worker in the lane (27).

### 2.6.3 Conflict and Event Studies

Conflict and event studies have been used since the 1960s and 1970s for transportation safety studies where monitoring actual collisions is impractical or not feasible (28, 29, 30). The conflicts are used as surrogate measures to determine the safety of the area being observed. The idea is that the factors that influence the types and amounts of conflicts also influence collisions. A conflict is an event in which two or more vehicles try to share the same place on the road at the same time. This usually involves evasive maneuvers like swerving and braking. Generally, conflict and event studies are performed for an hour at an intersection. They can be modified to fit the needs of the situation or study that requires their use.

## CHAPTER 3

### METHODOLOGY

he development of this research study, and in an effort to achieve the overall goal and supporting objectives, a series of tasks were established. The tasks were designed to allow for successful completion of the goal and proper evaluation of the data. The relationship between the tasks and specific objectives is presented in Figure 1.

The tasks, which are outlined below, include a literature review, work zone crash data and citation analysis and assessment, crash narrative analysis, field observations and analysis, and documentation of findings.

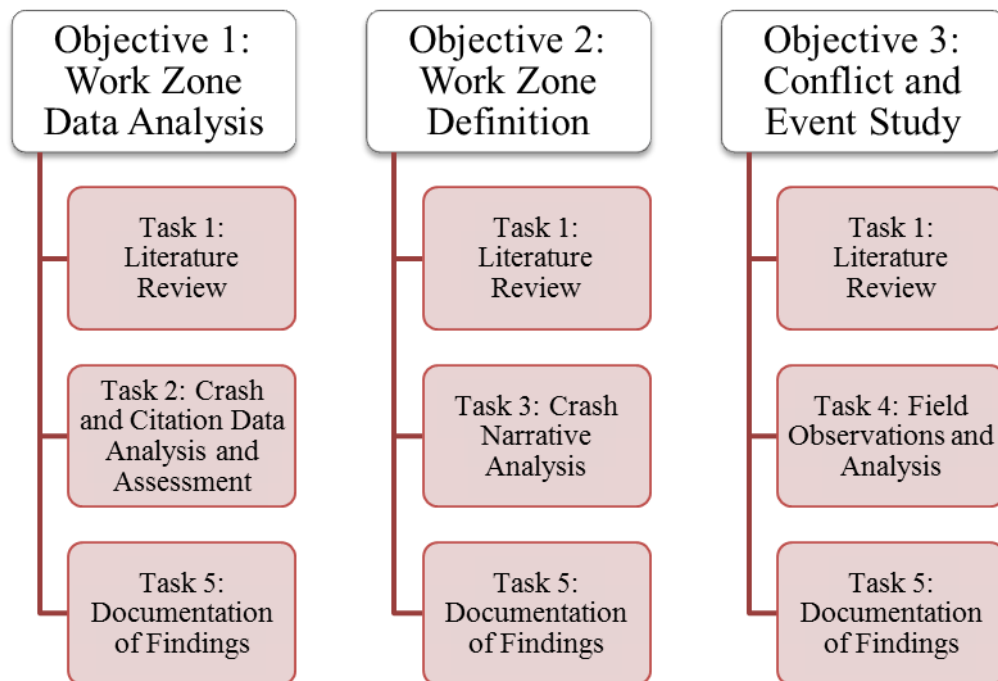

**FIGURE 1 Relationship of objectives and tasks.**

### 3.1 Task 1: Literature Review

The first research task was initiated at the start of this thesis and remained ongoing throughout the duration of the research. Specifically, the literature sought and reviewed was consistent with the research goal and three objectives set forth as related to work zone safety. Subtopics included current research standards and guidelines regarding work zone definitions, work zone crashes, CMV specific work zone crashes, and citation usage in data analysis, work zone design and layout, as well as conflict and event study techniques. The literature review is included in the background section of this thesis and presented in the previous section.

### 3.2 Task 2: Crash and Citation Data Analysis And Assessment

To address the research goal associated with quantification of the impact of work zone crash definitions, a research task centered upon crash data analysis was developed. This task required the use of several databases to determine the nature of work zone crashes. This was completed using the Warehouse and SAFETYNET as well as the UMass Safe CMV Query Tool. The data within these databases is from police-reported crash report form fields as well as research efforts by state officials to compile information from CMV crashes. This task is divided into three part, crash data analysis, CMV specific data analysis, and crash and citation data analysis.

### 3.2.1 Crash Data Analysis

The crash data analysis methodology was developed to address the first part of the first objective of this research. The crash data obtained for the analysis was queried from the Warehouse. The process in which the data is obtained and analyzed in this research is described below.

#### 3.2.1.1 UMass Safety Data Warehouse

In order to identify and analyze work zone related crash data, an understanding of the data collection and storage process is essential. Data used for this research was from the Warehouse which resides within UMass Safe. The Warehouse, shown in Figure 2 stores 13 different data sets such as crash and citation, health care and hospital, and CMV data which are all supplied by several different organizations such as the Registry of Motor Vehicles (RMV), the Massachusetts State Police (MSP), the Massachusetts Division of Health Care Finance and Policy, and the Office of Vital Statistics. In many instances, the various databases are able to be linked, allowing for more sophisticated analysis through cross-referencing of the information contained within the Warehouse.

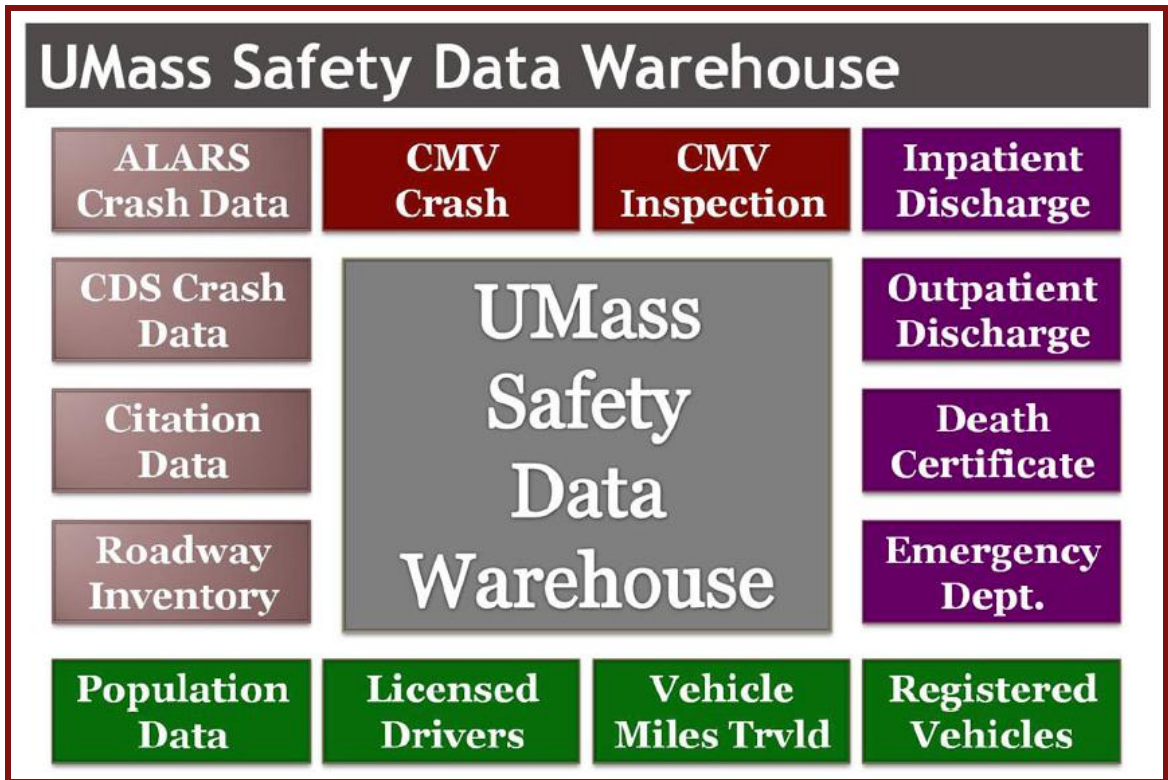

**FIGURE 2 UMass Safety Data Warehouse.**

Enforcement officials in Massachusetts fill out a standard police crash report form for crashes they respond to with damage of over \$1000 to the vehicles involved. The crash report form, presented in Figure 3 with a full copy in Appendix B, has over 40 fields of information to fill out like weather, driver, and vehicle characteristics as well as a narrative section where the officer can describe the details of the crash. The fields are divided into crash, vehicle, and person level information, each becoming more detailed. This form is sent either electronically or in paper form to the RMV. The Massachusetts RMV assigns each crash with a unique identifier and enters the associated information into the Crash Data System (CDS). If the crash report form is only partially filled out, the information may be supplemented from the operator’s report form if a party in the crash opted to fill one out.

**Commonwealth of Massachusetts**  
**Motor Vehicle Crash**  
**Exchange Form**

Date of Crash \_\_\_\_\_ Time of Crash \_\_\_\_\_ City/Town \_\_\_\_\_

State Police   
Local Police   
MRTA Police   
Other

< LOCATION >

**AT INTERSECTION:**      **NOT AT INTERSECTION:**

Route# _____ Direction _____ Name of Roadway/Street _____ At _____ Route# _____ Direction _____ Name of Intersecting Roadway/Street _____ Also at Intersection with _____ Route# _____ Direction _____ Name of Intersecting Roadway/Street _____	Route# _____ Direction _____ Address # _____ Name of Roadway/Street _____ Mile Marker _____ Feet [N S E W] of _____ Feet [N S E W] of _____ Feet [N S E W] of _____ Route# _____ Intersecting Roadway/Street _____ Landmark _____
--------------------------------------------------------------------------------------------------------------------------------------------------------------------------------------------------------------------------------------------------------------	-----------------------------------------------------------------------------------------------------------------------------------------------------------------------------------------------------------------------------------------------------

Please Select One of the Following:  Vehicle 1 \_\_\_\_# Occupant  Hit/Run  Moped

License # \_\_\_\_\_ St \_\_\_\_\_ DOB/Age \_\_\_\_\_ Reg # \_\_\_\_\_ Reg Type \_\_\_\_\_ Reg State \_\_\_\_\_  
 Sex \_\_\_\_\_ Lic. Class \_\_\_\_\_ Lic. Restrictions \_\_\_\_\_ CDL Endorsement \_\_\_\_\_ Veh. Year \_\_\_\_\_ Veh. Make \_\_\_\_\_ Veh. Config. \_\_\_\_\_  
 Operator: Last \_\_\_\_\_ First \_\_\_\_\_ Middle \_\_\_\_\_ Address: Last \_\_\_\_\_ First \_\_\_\_\_ Middle \_\_\_\_\_  
 City \_\_\_\_\_ State \_\_\_\_\_ Zip \_\_\_\_\_ City \_\_\_\_\_ State \_\_\_\_\_ Zip \_\_\_\_\_  
 Insurance Company \_\_\_\_\_

**Instructions**  
 According to Massachusetts General Laws, Chapter 90, Section 26: If the damage to any one vehicle or property is over \$1,000 or if there is an injury to any person, you are required to complete a crash report within 5 days of the date of the crash.  
 Please obtain a copy of the operator crash report from your local police department, Registry branch office or from the RMV Website: [WWW.MASS.GOV/RMV](http://WWW.MASS.GOV/RMV) and submit the original to:  
 Registry of Motor Vehicles  
 P.O. Box 55889  
 Boston, MA 02200-5889  
 Attn: Crash Records  
 Also, be sure to forward a copy to your insurance agency, the local police department where the crash occurred, and retain a copy for yourself.

Please Select One of the Following:  Vehicle 2 \_\_\_\_# Occupant  Non-Motorist A Type \_\_\_\_\_ Action \_\_\_\_\_ Location \_\_\_\_\_ Condition \_\_\_\_\_ Hit/Run  Moped

License # \_\_\_\_\_ St \_\_\_\_\_ DOB/Age \_\_\_\_\_ Reg # \_\_\_\_\_ Reg Type \_\_\_\_\_ Reg State \_\_\_\_\_  
 Sex \_\_\_\_\_ Lic. Class \_\_\_\_\_ Lic. Restrictions \_\_\_\_\_ CDL Endorsement \_\_\_\_\_ Veh. Year \_\_\_\_\_ Veh. Make \_\_\_\_\_ Veh. Config. \_\_\_\_\_  
 Operator: Last \_\_\_\_\_ First \_\_\_\_\_ Middle \_\_\_\_\_ Address: Last \_\_\_\_\_ First \_\_\_\_\_ Middle \_\_\_\_\_  
 City \_\_\_\_\_ State \_\_\_\_\_ Zip \_\_\_\_\_ City \_\_\_\_\_ State \_\_\_\_\_ Zip \_\_\_\_\_  
 Insurance Company \_\_\_\_\_

**Obtaining Crash Report Copies**  
 If you would like to obtain a copy of the police report or another operator report, please send a letter to the address above with a check for \$10 for each requested report made payable to: RMV. Please note that the \$10.00 fee is a search fee, not for the crash report itself and therefore is non-refundable.  
 In addition to your name and address, the following items should be included in your letter to identify the report you are requesting:  
 • Date of the crash  
 • Time of the crash  
 • City/Town where crash occurred  
 • Registration number and/or license number of at least one vehicle involved  
 Please allow at least 4 weeks from the date of the crash before submitting your request.

Form No. 3366 CMA-03 REV. 5-8 1997 000443

MIDDRE WALLACE

**FIGURE 3 Massachusetts police crash report form.**

Once in CDS, the Safety Section of the Highway Infrastructure Division of MassDOT uses a geocoder from Geonetics to locate and document x and y coordinates for each crash. This typically results in the successful location of approximately 90 percent of the crashes. The geocoded information is periodically transferred into CDS. The data from CDS is then provided to the Warehouse on a quarterly basis. CDS only retains information for three years, but the Warehouse stores the information for

analyzing current trends as well as historical patterns in the data. The flow of information into the Warehouse can be seen in Figure 4..

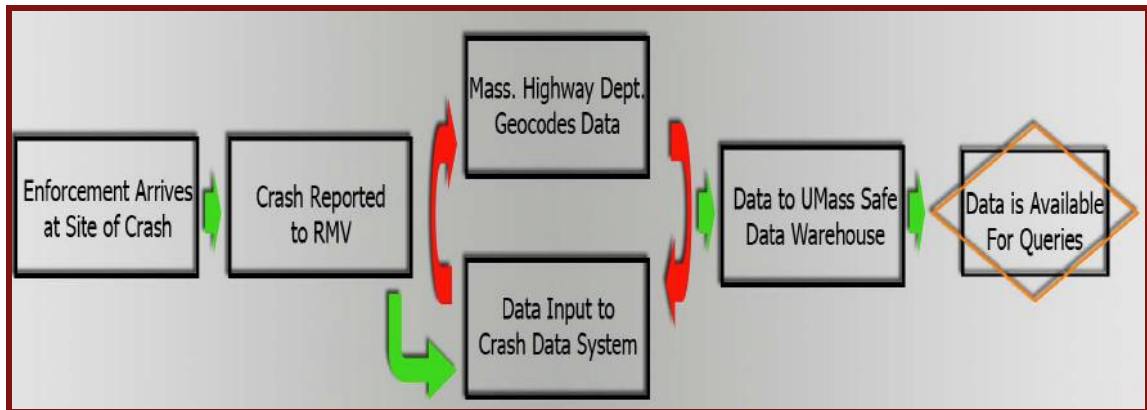

**FIGURE 4 Data flow for the UMass Safety Data Warehouse.**

#### 3.2.1.2 Crash Data Characteristics Analyses

Police reported crash report form data was obtained for all crashes between January 1, 2007 and December 31, 2009 within the Commonwealth of Massachusetts. The crash report form includes a field asking whether a crash is work zone related or not. This field was used to initially divide the data into two categories, work zone related and non-work zone related. All crashes listed as not work zone related, unknown, invalid, unreported, etc., or left blank were considered non-work zone related. A total of 398,604 crashes were examined over the three year period, 8,123 of which were categorized as work zone related, and 390,481 of which were, for the purposes of this study, non-work zone related. Certain fields were chosen from crash and vehicle level to analyze. These fields were divided into three categories: crash level with chi square analysis, crash level, and vehicle level and are presented in Table 2. A chi square analysis was completed for

three crash level fields to determine the extent to which work zone related crashes differ from non-work zone crashes. In the crash report form, several fields allow the input of more than one variable. Two of the chosen fields, weather conditions and driver contributing code, provided that option. For the purposes of this study, the data for each of the fields was aggregated into one set of variables each.

**Table 2 Crash Data to be Analyzed**

<u>Crash Level with Chi Square Analysis</u>  Crash Time Injury Status Description Manner of Collision	<u>Crash Level</u>  Month Light Conditions Weather Conditions Trafficway Description School Bus Related First Harmful Event Location First Harmful Event
<u>Vehicle Level</u>  Most Harmful Event Driver Contributing Code Vehicle Configuration Code Vehicle Action Prior to Crash	

### 3.2.2 Commercial Motor Vehicle Data Analysis

This part of Task 2 was established to analyze CMV crashes as a specific data set as set forth in the first objective of this research. The data for analysis in this task was provided through a series of steps from multiple organizations. The initial CMV information came from police crash report forms. If a CMV is involved in a crash, there is a separate truck/bus information section, highlighted in Figure 5, which must be

completed. When the crash report form indicates that a crash involved a CMV, either from an option in the vehicle configuration code or the truck and bus information section, CDS sends that information to the MSP. The MSP examine the information and decide if it is complete and accurate. The information is then sent to SAFETYNET where it is stored along with CMV information from other states across the country for use in safety analysis.

Owner (Last, First, Middle)	Address	Phone #	34-Type	Description of Damaged Property
<b>Truck and Bus Information:</b>				
Registration # _____ (From Vehicle Section)				
Carrier Name _____		Carrier Issuing Authority Code _____		35
Address _____		City _____	St _____	Zip _____
US DOT # _____	State Number _____	Issuing State _____	ICC # _____	Interstate _____
Cargo Body Type Code _____	37	Gross Vehicle Weight _____	38	
Trailer Reg # _____	Reg Type _____	Reg State _____	Reg Year _____	Trailer Length _____
<b>Hazard Information:</b>				
Placard _____	40	Material 1 digit # _____	41	Material Name _____
		Material 4 digit # _____		Release code _____
				42
Police Officer Name (Printed Name)	Signature	ID/Badge #	Department	Pin/Inn/Barracks
CDPI 112486				Date

**FIGURE 5 Truck and bus information in the police crash report form.**

### 3.2.2.1 SAFETYNET

SAFETYNET is a tool used by the Federal Motor Carrier Safety Administration (FMSCA) to help accomplish their goal of reducing crashes, injuries, and fatalities involving large trucks and busses. SAFETYNET was designed as a database management system to help the agency harness available motor carrier safety and identification information and monitor their safety performance to better address and enforce or correct carriers who engage in high risk behavior. It is an Oracle based system

and is compatible with other federal software such as Aspen, Safety and Fitness Electronic Records (SAFER), and the Motor Carrier Management Information System (MCMIS). Originally, SAFETYNET was designed for state officials' use but has grown to include federal and local offices (31, 32).

SAFETYNET is intended to promote information sharing between states. State and local officials input safety and identification information into the database from software in their respective offices. Identification information includes but is not limited to truck/bus driver names, social security numbers, license numbers, dates of birth, contact information, and vehicle identification numbers (VIN). Examples of safety information include crash data, inspection reports, compliance review data, assignments, complaints, and enforcement information. The accuracy of the information is the responsibility of those who input it into the system, such as state officials and police departments. SAFETYNET ensures the quality of data internally as well as the completeness of information in the network (31, 32).

Information is sent to SAFETYNET and then processed. From there, the processed data is sent through the SAFER Data Mailbox and stored in the MCMIS. MCMIS then creates safety data snapshots and summaries as well as motor carrier census reports. Those reports are uploaded through SAFER on a weekly basis (32). Figure 6 graphically depicts the flow of information to and from SAFETYNET.

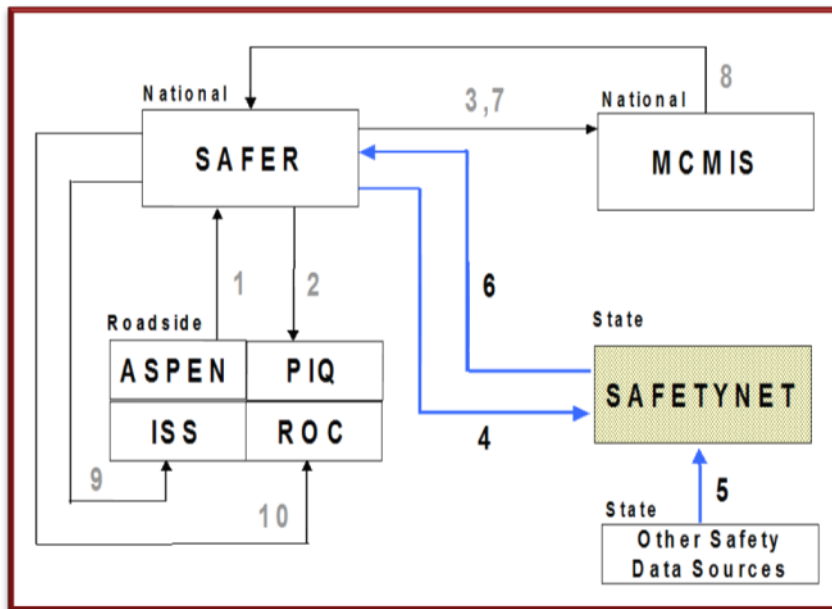

**FIGURE 6 SAFETYNET information flow (32).**

Motor carriers, as well as state and federal officials then have access to this information. Compliance officials perform research studying and analyzing the crash and inspection data and then create reports. Using the data, they perform inspections, track issues and trends, and take actions against non-compliance. Enforcement officials often use the data to search driver histories, search inspection records, track inspection and crash data, and research compliance issues. Identifier information can be used to contact drivers and companies to request additional information or take action against offending drivers and companies (31, 32).

### 3.2.2.2 Massachusetts Commercial Vehicle Crash Data Tool

UMass Safe has a CMV query tool called the *Massachusetts Commercial Vehicle Crash Data Tool* (CMV Query Tool). The query tool is able to be accessed by analysts

working within the served network. The tool uses the Warehouse along with SAFETYNET information and provides a way to access and easily examine the CMV crash data. It was developed with the help of the MSP Commercial Vehicle Enforcement Section (MSP CVES or Truck Team) to create an interactive web-based approach to improve collection and utilization of CMV crash data by law enforcement officials in Massachusetts. The information accessed includes details of the crashes as well as information on the general quality of the included data. The MSP are able to easily determine high risk locations to pinpoint target areas for enforcement.

#### 3.2.2.3 CMV Data Analysis

Following the analysis described above in Section 3.2.1, an analysis was completed with CMV specific data obtained through the CMV query tool as described above. Data was obtained for January 1, 2007 to December 31, 2009 for Massachusetts. The data was again divided into work zone and non-work zone related crashes, but CMV specific. A total of 6,987 crashes were examined, with 293 being work zone related, and 6,696 being non-work zone related. The fields chosen for analysis were divided into crash and vehicle level analysis as seen in Table 3. Like explained earlier, the driver contributing codes were combined into one data set.

**TABLE 3 Chosen CMV Fields For Analysis**

<u>Crash Level Analysis</u>	<u>Vehicle Level</u>
Light Conditions Road Surface Conditions Trafficway Description Weather Conditions	Driver Contributing Code Most Harmful Event

### 3.2.3 Citation Analysis

In an effort to examine the relationship between crashes and citations for both work zone and non-work zone situations, an analysis of a linked crash-citation dataset was completed. The citation data, linked with crash report form data was also obtained from the Data Warehouse

Police reported crash report form and citation data were obtained for all crashes in which a citation was issued between January 1, 2007 and December 31, 2009 within the Commonwealth of Massachusetts. Initially, the data was divided into two categories: all crashes, and crashes in which a citation was issued. Three categories on the police crash report form were then chosen to be analyzed between the two in order to determine whether they were representative of each other:

- Manner of Collision
- First Harmful Event Location
- Vehicle Action Prior to Crash

Initially, a chi square analysis was completed to determine the extent to which crashes where a citation was issued were representative of crashes at-large. More specifically, each of the crash-related fields was compared for statistical significance between all crashes and crashes with citations. The results indicated that the two datasets were significantly different ( $p < 0.001$ ) in all instances indicating that the crashes where a citation occurred are not representative of all crashes. Logically, this finding makes sense given that citations are only likely to be issued for certain types/levels of crashes; however, it is important to note that as a result of this fact caution should be employed when using the results of this research as a generalization for all crashes.

The crash report form work zone related field was used to further divide the data into work zone and non-work zone related. A total of 58,800 crashes were analyzed with an associated 103,734 citations. The citations were apportioned into six data sets according to year and work zone involvement. An initial analysis was completed on the data, providing a basic understanding of the type of data was in the data set. These initial analyses included:

- Number of Crashes
- Number of Citations
- Number of Single Citation Crashes
- Number of Multiple Citation Crashes
- Average Number of Citations Issued per Crash
- Average Number of Citations Issued per Multiple Citation Crash
- Number of Types of Citations Issued

Once this analysis was complete, the individual years of data were aggregated into two data sets using the work zone related field in the crash report form: work zone related citations; and non-work zone related/unknown work zone status (non-work zone related). An analysis was then performed on the two data sets. All citations were analyzed as individual events, not on a per crash basis.

The citations were ranked according to the most common citations that are issued in work zone and non-work zone related crashes. Chi square analysis was employed for each of the top 20 citations in both categories to determine whether the differences in numbers between work zone and non-work zone citations were statistically significant.

An analysis of the data was then completed using categories and fields within the crash report form and relating them to the amount and types of citations issued for each field response. The categories chosen for analysis were as follows:

- Time of Crash
  - Alcohol and Drug Related
- Injury Status Description
- Manner of Collision
- First Harmful Event Location
- Most Harmful Event
- Driver Contributing Code
- Vehicle Action Prior to Crash

The separated data was aggregated for all three years for both work zone and non-work zone/unknown crashes. The data was then separated according to chosen crash report form fields of interest, such as *time of day*, *crash injury status*, and *most harmful event*. These factors were then analyzed for the frequency and types of citations issued as a result of crashes involving those factors. These quantitative characteristics were compared for work zone involvement and qualitatively described. Each field within the categories chosen above were then investigated using chi square analyses to determine if the individual fields were significantly different between work zone and non-work zone related citations.

As in the crash data analysis, the *driver contributing code* data was combined into one data set. A citation ranking was not completed for the driver contributing code due to double counting that would result from using both driver contributing code fields.

#### 3.2.4 Crash and Citation Data Analysis Results

The qualitative and quantitative results from this analysis are included in the text, tables, and figures in the results, contained in Section 4 of this thesis, followed by a discussion in the conclusions and recommendations in Section 5.

### 3.3 Task 3: Crash Narrative Analysis

Analyzing work zone crash data requires assessment of the quality of the work zone related field on the police reported crash report form. As described above in the previous task, the crash report form provides an opportunity for officers to fill out details from a crash in the narrative section as seen below in Figure 7. These narratives are

available in electronic form in the Warehouse. Not all crashes have electronic narratives. Of the 398,604 crashes available in the Warehouse from January 1, 2007 to December 31, 2009, 93,089 (23.35 percent) have electronic narratives. Of those narratives, 2,811 were from crashes marked as work zone related, about three percent of the crashes, and 90,279 were from crashes marked as non-work zone related. The narrative task was divided into two parts, a double blind narrative search, and a key word search.

→ = Direction    1 = Vehicle 1    2 = Vehicle 2    Q = Pedestrian

Crash Diagram:    ic: → 1 → 2 → Q

If Crash Did Not Occur on a Public Way:

- Off-Street Parking Lot
- Garage
- Mall/Shopping Center
- Other Private Way

Indicate North by Arrow

Crash Narrative:

Witnesses:

Name (Last, First, Middle)	Address	Phone #	Statement

Property Damages:

Owner (Last, First, Middle)	Address	Phone #	34-Type	Description of Damaged Property

Truck and Bus Information:    Registration # \_\_\_\_\_ (From Vehicle Section)

Carrier Name \_\_\_\_\_    Carrier Issuing Authority Code

Address \_\_\_\_\_ City \_\_\_\_\_ St \_\_\_\_\_ Zip \_\_\_\_\_

US DOT # \_\_\_\_\_ State Number \_\_\_\_\_ Issuing State \_\_\_\_\_ ICC # \_\_\_\_\_ Interstate

Cargo Body Type Code  Gross Vehicle Weight

Trailer Reg # \_\_\_\_\_ Reg Type \_\_\_\_\_ Reg State \_\_\_\_\_ Reg Year \_\_\_\_\_ Trailer Length

Hazard Information:

Hazard  Material 1 digit #  Material Name \_\_\_\_\_ Material 4 digit # \_\_\_\_\_ Release code

Police Officer Name (Please Print) \_\_\_\_\_ Signature \_\_\_\_\_ ID/Badge # \_\_\_\_\_ Department \_\_\_\_\_ Precinct/Barracks \_\_\_\_\_ Date \_\_\_\_\_

CPD 112490

**FIGURE 7 Narrative section of Massachusetts crash report form.**

### 3.3.1 Double Blind Narrative Search

Initially, the narratives were divided into two categories, work zone related and non-work zone related, similar to the previous task. One hundred narratives in each of the categories were chosen at random. A double blind test was developed in order to determine the extent to which work zone and non-work zone crash narratives indicate work zone involvement. Each of seven individuals, all transportation engineering graduate students, were given 14 to 15 narratives from the work zone and non-work zone related categories, totaling 100 of each. The individuals were told which groups were marked as work zone related or not. They were given a worksheet to fill out, presented in Appendix C, which asked for the crash number, whether it was from the work zone related or non-work zone related sample, and the amount of work zone related words found in the sample. The individuals were given the ANSI definition for a work zone, work zone accident, motor-vehicle in transit, and working motor vehicle, as found in Appendix A and were asked to read through them carefully. They were also instructed that, as in the FHWA definition stated earlier, crashes that occur as a result of a queue that developed from a work zone should be counted as work zone related. They were also given 12 example narratives with an associated filled out worksheet. The students were asked to fill out their worksheets as best they could, record the frequency that specific words presented themselves in the narratives, and indicate the number of times any new words they felt were work zone related were present. Simultaneously, the lead researcher randomly chose two to three of both work zone and non-work zone related narratives from each of the students' assigned narratives to replicate the analysis. The results from

the students' narrative searches and the researchers were then compared for consistency and accuracy.

### 3.3.2 Key Work Narrative Search

Once the double blind narrative search was complete, a list of search words was developed for the second step of the narrative search, the key word search. The chosen key words were determined three ways: through common knowledge of work zone terminology, the narrative search in the previous section, and a separate search in the form of a read-through of 250 more work zone related narratives. The list of words was developed for a search of non-work zone narratives with the intention of finding narratives that may have been mislabeled as non-work zone crashes and is presented in the Section 4. The narratives within the Warehouse from crashes labeled as non-work zone related in the crash report form field were then queried using those key words. At least 30 narratives were read whenever possible. If the search yielded less than 30 results, all were read individually. The narratives that were positive for the search words were then randomly sampled and read through individually as in Part 1 to determine the extent of which the word characterized the crash as work zone related. The words were assigned a discriminating power based on the percent of non-work zone labeled narratives that the key words yielded that were deemed to actually be work zone related. All narratives were then queried for the number of difference key words or phrases present in the narrative. The words chosen for this search were the ones that yielded a discriminating power of over 20 percent. So if three words were found in the narrative, it was probable that about 60 percent of the narratives with those three words indicated

work zone involvement. An example of a narrative with key words that indicates work zone involvement can be found in Figure 8.

	<b>on a Public Way:</b> <input type="checkbox"/> Off-Street Parking Lot <input type="checkbox"/> Garage <input type="checkbox"/> Mall/Shopping Center <input type="checkbox"/> Other Private Way								
	<b>Indicate North by Arrow</b> 								
<b>Crash Narrative:</b> VEHICLE #1 OPERATING IN LEFT LANE ENTERING A CONSTRUCTION ZONE WHERE THE BREAKDOWN AND RIGHT TRAVEL LANES WERE CLOSED USING ORANGE TRAFFIC CONES AND AN ARROW BOARD. THERE WERE ALSO ONE MILE, 1/2 MILE, QUARTER MILE AND LANE CLOSED SIGNS PRIOR TO ENTERING THE CLOSURE. VEHICLE #1 HAD MOVED TO THE LEFT AND WAS AT THE PROPER 45 MPH REDUCED SPEED. VEHICLE #2, AN UNKNOWN TRACTOR TRAILER UNIT WAS ENTERING THE CLOSURE AND WAS TO THE RIGHT OF VEHICLE #1. VEHICLE #2 MOVED LEFT AND THE TANDEM WHEELS ON THE TRACTOR MADE CONTACT WITH THE RIGHT FRONT FENDER, AND DOOR OF VEHICLE #1. THE OUTSIDE MIRROR ON VEHICLE #1 WAS ALSO BROKEN OFF. OPERATOR OF VEHICLE #1 WAS SHAKEN UP AND UNABLE TO OBTAIN ANY IDENTIFYING INFORMATION OFF VEHICLE #2. VEHICLE #2 LEFT THE SCENE AND VEHICLE #1 WAS ABLE TO BE DRIVEN FROM THE SCENE AFTER FILING A "HIT AND RUN " REPORT.									
<b>Witnesses:</b> <table border="1" style="width: 100%; border-collapse: collapse;"> <thead> <tr> <th style="width: 40%;">Name (Last, First, Middle)</th> <th style="width: 20%;">Address</th> <th style="width: 20%;">Phone #</th> <th style="width: 20%;">Statement</th> </tr> </thead> <tbody> <tr> <td> </td> <td> </td> <td> </td> <td> </td> </tr> </tbody> </table>		Name (Last, First, Middle)	Address	Phone #	Statement				
Name (Last, First, Middle)	Address	Phone #	Statement						

**FIGURE 8 Work zone related narrative example .**

### 3.3.3 Narrative Search For Data Analysis Validation

In addition to the above searches, a read-through was performed to validate the data results from the crash data analysis. Two fields, *first harmful event* and *most harmful event*, include an option for *collision with work zone maintenance equipment*. The narratives that were available for the categories in the non-work zone related crashes were read through and checked to make sure they were in fact, not work zone related.

### 3.3.4 Narrative Search Results

The results of both parts of the narrative searches, the double blind narrative search, and key word narrative search are presented in the results section, Section 4 of this thesis.

### 3.4 Task 4: Field Observations – Conflict and Event Study

This research provided an opportunity to observe and analyze local small scale work zones. More specifically, 14 work zones were observed using surrogate measures of safety assessment as a means for identifying any safety-related hazards in the work zone. Existing conflict and event study procedures and worksheets as outlines in the background were adapted to allow for the spotting of issues in operating work zones (28). To achieve the overall research task, the conflict and event studies were carried out in five steps which are presented in Figure 9.

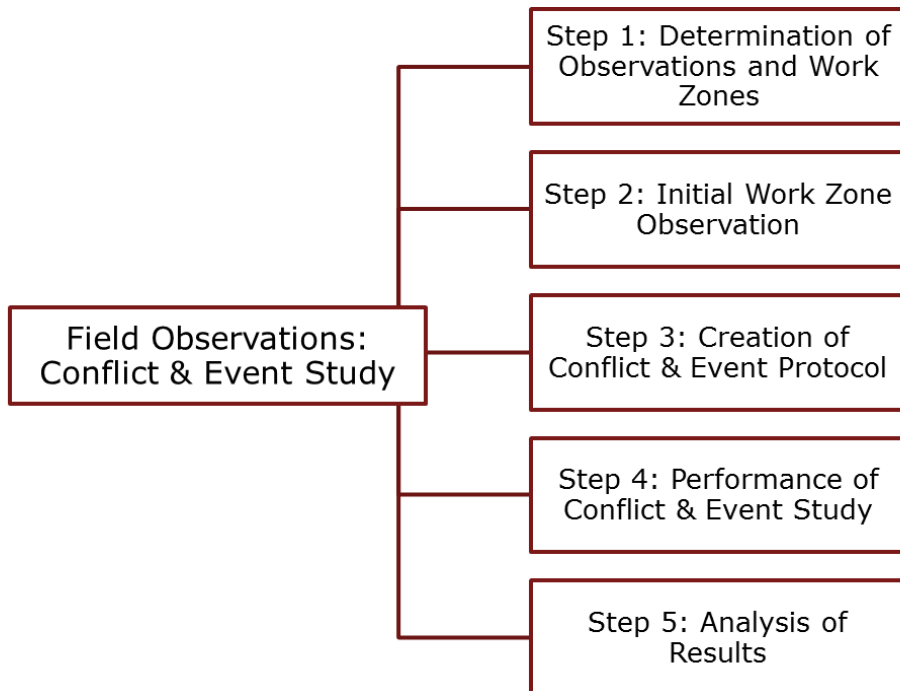

**FIGURE 9 Relationship between Task 4 and methodologic steps.**

### 3.4.1 Determination of Observations and Work Zones

The first of these steps was to determine what type of work zones would be observed and where and when they would occur as well as establish observation periods. Initially, the work zones to be observed had to be identified. This was done through a series of methods including talking to MassDOT District 2 about construction locations, using websites including [www.masstraveler.com](http://www.masstraveler.com) which provides construction alerts along roadways in Massachusetts, the MassDOT Highway Division project webpage which lists current and past roadway construction projects searchable based on city location, calling local police departments and their detail offices, local Departments of Public Works, driving through areas of known construction and finally through speaking with on-duty detail officers and construction workers for suggestions as to where there would be construction in the upcoming weeks. A total of 14 work zones were observed over a period of two months, August and September. The work zones were selected based upon the ability to provide the opportunity for evaluation of a sample of several different types of work zone setups and therefore capture typical driver behavior in each of the work zones. A researcher observed every work zone, often with the help of an additional engineering student.

### 3.4.2 Initial Work Zone Observation

An initial observation was completed and using that observation, a method was developed to observe the 14 work zones. The researcher observed the work zone for an hour, taking notes of characteristics and events. In addition the detail officer was spoken with to determine his input on what types of characteristics are important to note for work

zone safety. The first work zone is not included in the analyses because it was used as a base model for observing the work zones and developing the observation methodology.

### 3.4.3 Creation of Conflict and Event Study

Using the observations, a conflict and event study was created that could easily be performed in chosen work zones by several different observers with similar results. The conflict and event studies were developed to allow other researchers, professionals, and roadside workers to use them in the future to gather their own data or determine specific problem areas quickly and easily.

A worksheet was created for the observers to fill out as seen in Appendix D. The observers were asked to fill out information regarding many different aspects and characteristics of the work zone. These included: date, observer, time of day, weather, and location. They were next asked to comment on the work zone setup, including signs leading up to the work zone, type of lane closure, number of police and workers, and equipment. Observations were an hour wherever possible. Due to the mobile nature of many work zones and the difficulty of finding work zones, sometimes the work zones were unable to be observed for the entire hour-long period. The observers were also required to take pictures of the work zone and approaches.

During the observation period, , the observers were asked to keep a volume count, track of the type of work going on, the types of equipment being used, the numbers of workers and police, as well as any changes in the layout of the work zone. In certain work zones, speeds were recorded using a Lydar gun for vehicles entering, exiting,

within, and not associated with the work zone. Due to the nature of many of the work zones, all speeds at all locations were not able to be recorded.

Finally, the observers were asked, for the entire period of observation, to record any conflicts or events they witness. The observers watched for evasive maneuvers like breaking or weaving that indicate a conflict which could potentially cause a crash. In addition, the observers were asked to describe in detail unusual actions or situations that are not typical for a normally behaving vehicle, like horn honking to determine what type of events are occurring and to facilitate the analysis process later. Events were categorized using traffic violations as well.

#### 3.4.4 Performance of Conflict and Event Study

The 14 observations were completed in two months. The observers filled out a worksheet for each work zone and recorded all observed conflicts and events for each period. Pictures were also taken at each site. The observers asked to remain in an area that did not disturb either the construction workers or drivers to prevent influencing them and biasing the results of the study. A verification method was used, in the form of two people watching the work zone at once and comparing notes on conflicts and events, to ensure uniformity between multiple observers.

#### 3.4.5 Analysis of Results

Once the 14 work zones were observed, the data was combined and analyzed to determine the factors and causes most commonly found in the observations for the different types of work zones. A thumbnail and description table was created for the

work zones which were each given a unique ID number and the characteristics and recorded speeds were reported in the matrix form. The conflicts and events were divided into eight categories: traffic infractions, speed related, merge related, setup related, equipment related, age related, other, and serious conflicts and events.

### 3.5 Task 5: Documentation of Findings

The findings of this research resulting from the analysis of crash and citation data, narrative searches, and conflict and event studies, as well as any resulting findings and conclusions relating to work zone challenges are documented in the form of this Master's Thesis for submission to the Graduate School of the University of Massachusetts Amherst (33).

## CHAPTER 4

### RESULTS

The results from the analyses of the data in response to the overarching goal of improving work zone safety and the associated objectives of analyzing crash data, varying work zone definitions, and completing conflict and event studies are presented in the section below in a format consistent with the methodology. More specifically, results are presented for the crash data analyses, narrative search analyses, and conflict and event studies.

#### 4.1 Crash Data Analysis

Analysis of crash data is an inherent part of understanding work zone related crashes. A number of variables influence the causes and outcomes of crashes. These variables were able to be obtained through the police reported crash report form information queried from the UMass Safety Data Warehouse. As previously discussed in the Methodology, three types of crash data were analyzed to provide a better understanding of the nature of work zone crashes: crash data, CMV specific crash data, and citation data from crashes. All data presented below is presented for known variables within the crash report form fields; unknown, not applicable, or invalid data was not included.

#### 4.1.1 Preliminary Crash Data Analysis

A preliminary analysis was originated as part of the proposal process in an effort to develop a sense of the available sample size for work zone crashes. The preliminary findings are presented in Table 4 and Figure 10. Table 4 consists of a breakdown of crashes marked as work zone related in the police crash report form from 2007 to 2009. The crashes are divided into the types of injuries that were reported as resulting from the work zone related crashes for each year. Figure 10 averages data from Table 4 over the three year period and presents the averages for each injury type as a percent of the total work zone related crashes that occurred.

**TABLE 4 Injuries Resulting From Work Zone Related Crashes**

<b>Injury Status</b>	<b>Year</b>		
	<b>2007</b>	<b>2008</b>	<b>2009</b>
Fatal	4	3	7
Incapacitating	67	50	79
Non-Incapacitating	348	270	433
Possible	446	439	574
No Injury	3,625	3,426	5,134
Unknown or un-reported	1,518	1,308	1,366
<b>Total</b>	<b>6,008</b>	<b>5,496</b>	<b>7,593</b>

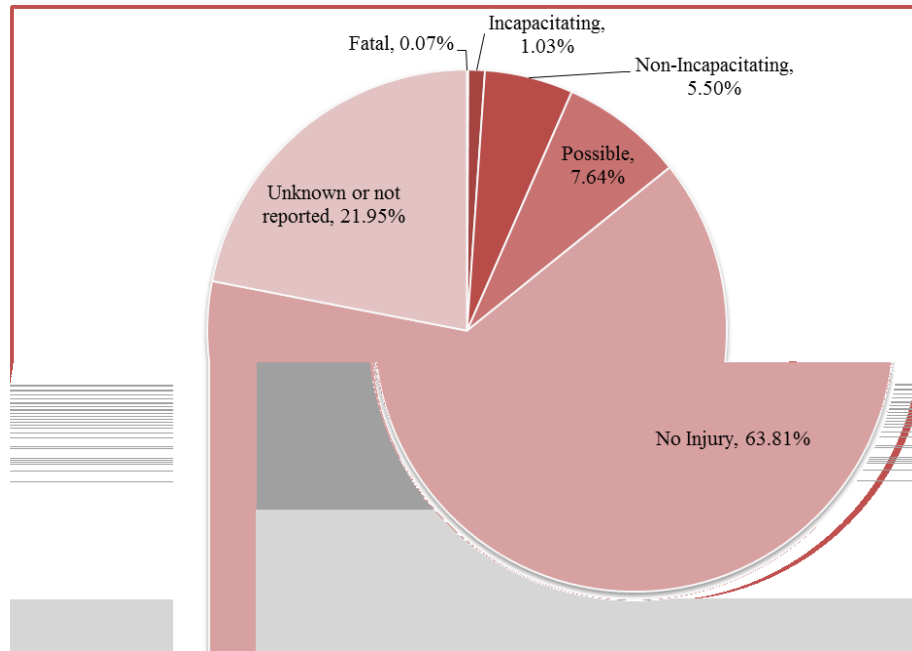

**FIGURE 10 Average percentage of work zone related crashes by injury status for 2007-2009.**

#### 4.1.2 General Crash Data Analysis

The queried police reported crash report form data yielded 57 fields of data for use in the data analysis and 15 fields were chosen for analysis based on relevance and interest in work zone crashes. The results of a generalized breakdown of the types of data are presented in Table 5. From January 1, 2007 to December 31, 2009, 935,524 occupants were reported as being in a total of 398,604 crashes in Massachusetts. 8,123, about two percent, of these crashes were marked as work zone related in the crash report form and 390,481 were either non-work zone related or unknown. The chosen crash factors were analyzed according to the approach explained in the methodology.

**TABLE 5 Generalized Crash Data Breakdown**

	<b>2007</b>	<b>2008</b>	<b>2009</b>	<b>Total</b>
<b>All Crashes</b>	144,507	136,374	117,723	398,604
<b>All Occupants</b>	339,520	319,247	276,757	935,524
<b>WZ Crashes</b>	2,562	2,375	3,186	8,123
<b>All WZ Occupants</b>	6,008	5,496	7,552	19,056
<b>Non-WZ Crashes</b>	141,945	133,999	114,537	390,481
<b>All Non-WZ Occupants</b>	333,512	313,751	269,205	916,468
*WZ denotes work zone related				

#### 4.1.2.1 Crash Level Analysis

The 398,604 crashes that occurred in Massachusetts from 2007 to 2009 were analyzed for work zone involvement in a number of crash level fields which were presented in the Methodology. These the results from that analysis are reported in Tables 6 and 7.

**TABLE 6 Crash Variables With P-Value**

	Work Zone Related Citations		Non-Work Zone Related Citations		P-Value
	Freq. (percent)		Freq. (percent)		
<b>Crash Time</b>					<0.0001
00:00 - 05:59	907 (11.17)		45,384 (11.62)		<0.0001
06:00 - 11:59	2,773 (34.14)		114,271 (29.26)		<0.0001
12:00 - 17:59	3,010 (37.06)		157,359 (40.30)		<0.0001
18:00 - 24:00	1,433 (17.64)		73,467 (18.81)		0.0074
<b>Injury Status Description</b>					0.2694
No Injury	5,100 (70.75)		246,440 (71.00)		0.6547
Non-Fatal Injury - Possible	1,034 (14.35)		49,754 (14.33)		1
Non-Fatal Injury - Non-Incapacitating	843 (11.70)		40,493 (11.67)		0.9203
Non-Fatal Injury - Incapacitating	210 (2.91)		9,388 (2.70)		0.2794
Fatal Injury	21 (0.29)		1,038 (0.30)		0.9203
<b>Manner of Collision</b>					
Single Vehicle Crash	1,588 (20.19)		79,777 (21.72)		0.0012
Rear-End	3,088 (39.27)		119,228 (32.46)		<0.0001
Angle	1,652 (21.01)		107,377 (29.23)		<0.0001
Sideswipe, Same Direction	1,058 (13.45)		37,084 (10.09)		<0.0001
Sideswipe, Opposite Direction	222 (2.82)		11,343 (3.09)		0.1785
Head On	191 (2.43)		10,875 (2.96)		0.0058
Rear to Rear	65 (0.83)		1,669 (0.45)		<0.0001

Crash time, injury status description and manner of collision were all chosen to be analyzed using chi square analysis as seen in Table 6. There were two injury status categories available in the Data Warehouse: *Injury Status Description*, and *Injury Status Code*. The latter is taken directly from the crash report form, while the former is entered as a result of further investigation. *Injury Status Description* was chosen for analysis because it is the more accurate set of data. The chi square analysis determines the extent to which the variables in each, work zone and non-work zone related crashes, differ and whether the difference is statistically significant. All crash times, between work zone and

non-work zone crashes differed significantly ( $p < 0.001$ ). Many of the *manner of collision* variables differed significantly as well, including *rear-end*, *angle*, *sideswipe-same direction*, and *rear-to-rear* ( $p < 0.0001$ ). *Single vehicle* crashes and *head on* crashes were also significantly different ( $p < 0.01$ ). *Sideswipe opposite direction* crashes were not statistically different between work zone and non-work zone crashes ( $p = 0.1785$ ). *Injury status description*, as an entire category, did not differ significantly between work zone and non-work zone related crashes ( $p = 0.2694$ ). In fact, possible *non-fatal injuries* did not differ statistically at all ( $p = 1$ ). Both *fatal* and *non-incapacitating non-fatal injuries* did not differ also ( $p > 0.9$ ).

**TABLE 7 Crash Level Analyses**

	Work Zone Related Citations		Non-Work Zone Related Citations	
	Freq.	(percent)	Freq.	(percent)
<b>Month</b>				
January	471	(5.80)	36,422	(9.33)
February	426	(5.24)	34,551	(8.85)
March	489	(6.02)	31,993	(8.19)
April	599	(7.37)	27,802	(7.12)
May	757	(9.32)	31,399	(8.04)
June	806	(9.92)	30,724	(7.87)
July	791	(9.74)	30,801	(7.89)
August	821	(10.11)	31,125	(7.97)
September	855	(10.53)	31,202	(7.99)
October	732	(9.01)	31,270	(8.01)
November	682	(8.40)	31,573	(8.09)
December	694	(8.54)	41,619	(10.66)
<b>Light Conditions</b>				
Daylight	5,789	(71.98)	265,733	(69.56)
Dawn	103	(1.28)	5,509	(1.44)
Dusk	156	(1.94)	11,236	(2.94)

Dark-Lighted Roadway	1,527	(18.99)	76,234	(19.96)
Dark - Roadway Not Lighted	407	(5.06)	20,050	(5.25)
Dark - Unknown Roadway Lighting	60	(0.75)	3,233	(0.85)
<b>Weather Conditions</b>				
Clear	6,633	(68.09)	275,079	(61.26)
Cloudy	1,670	(17.14)	81,411	(18.13)
Rain	1,038	(10.65)	53,036	(11.81)
Snow	249	(2.56)	26,517	(5.91)
Sleet, Hail, Freezing Rain	84	(0.86)	8,237	(1.83)
Fog, Smog, Smoke	30	(0.31)	1,513	(0.34)
Severe Crosswinds	15	(0.15)	668	(0.15)
Blowing Sand, Snow	23	(0.24)	2,556	(0.57)
<b>Road Surface Conditions</b>				
Dry	6,132	(76.78)	264,961	(69.71)
Wet	1,310	(16.40)	74,058	(19.48)
Snow	220	(2.75)	23,083	(6.07)
Ice	141	(1.77)	12,565	(3.31)
Sand, Mud, Dirt, Oil, Gravel	130	(1.63)	2,102	(0.55)
Water (Standing, Moving)	19	(0.24)	550	(0.14)
Slush	34	(0.43)	2,788	(0.73)
<b>Trafficway Description</b>				
Two-Way, Not Divided	3,970	(51.22)	229,030	(62.99)
Two-Way, Divided, Unprotected Median	1,190	(15.35)	55,215	(15.19)
Two-Way, Divided, Positive Median Barrier	1,847	(23.83)	51,013	(14.03)
One-Way, Not Divided	744	(9.60)	28,351	(7.80)
<b>School Bus Related</b>				
Yes	1,927	(24.11)	4,220	(1.12)
No	6,067	(75.89)	371,463	(98.88)
<b>First Harmful Event Location</b>				
Roadway	5,696	(86.50)	257,447	(82.83)
Median	100	(1.52)	4,240	(1.36)
Roadside	387	(5.88)	21,430	(6.89)
Shoulder-Paved	60	(0.91)	2,809	(0.90)
Shoulder-Unpaved	54	(0.82)	4,730	(1.52)
Shoulder-Travel Lane	20	(0.30)	463	(0.15)
Outside Roadway	268	(4.07)	19,702	(6.34)
<b>First Harmful Event</b>				
<i>Collision with</i>				
Motor Vehicle in Traffic	4,465	(68.38)	212,118	(68.51)
Parked Motor Vehicle	635	(9.72)	27,550	(8.90)

Pedestrian	222	(3.40)	5,374	(1.74)
Cyclist	64	(0.98)	3,381	(1.09)
Animal-Deer	32	(0.49)	4,266	(1.38)
Animal-Other	3	(0.05)	596	(0.19)
Moped	4	(0.06)	121	(0.04)
Workzone Maintenance Equipment	158	(2.42)	59	(0.02)
Railway (train, engine)	2	(0.03)	34	(0.01)
Other Movable Object	95	(1.45)	3,276	(1.06)
Curb	97	(1.49)	4,840	(1.56)
Tree	117	(1.79)	10,287	(3.32)
Utility Pole	172	(2.63)	12,241	(3.95)
Light Pole or Other Post/Support	86	(1.32)	4,756	(1.54)
Guardrail	119	(1.82)	7,800	(2.52)
Median Barrier	73	(1.12)	1,904	(0.61)
Ditch	55	(0.84)	1,679	(0.54)
Embankment	19	(0.29)	2,468	(0.80)
Bridge	13	(0.20)	550	(0.18)
Bridge Overhead Structure	9	(0.14)	322	(0.10)
Unknown Fixed Object	45	(0.69)	2,447	(0.79)
<i>Non-Collision</i>				
Overturn/Rollover	26	(0.40)	1,896	(0.61)
Jackknife	5	(0.08)	342	(0.11)
Other Non-Collision	12	(0.18)	947	(0.31)
Unknown Non-Collision	2	(0.03)	357	(0.12)

Additional crash level categories are presented in Table 7. The months generally only differed up to about two percent between work zone and non-work zone crashes. However, *January* and *February* saw differences of 3.53 and 3.60 percent respectively. Crashes in *April* were most similar with 7.37 percent of work zone crashes and 7.12 percent of non-work zone crashes. *November* was also very similar, with 8.40 and 8.09 percent of crashes.

Categories for *weather, light, and road surface conditions* were similar for work zone and non-work zone related crashes. The *weather conditions* for work zone and non-

work zone related crashes were most often *clear* (68.09 versus. 61.26 percent). *Cloudy* and *rainy* were second most common for both for both work zone and non-work zone crashes with 17.14 and 18.13 percent 10.65 and 11.81 percent respectively. The *light conditions* showed that work zone crashes occurred 71.98 percent of the time in *daylight* and in the *dark on a lighted roadway* 18.99 percent of the time. Non-work zone crashes occurred in those conditions 69.56 and 19.96 percent of the time. *Road surface conditions* were most commonly *dry* for work zone and non-work zone crashes (76.78 and 69.71 percent); however, about seven percent more work zone crashes were in *dry* conditions compared to the non-work zone crashes. In total, the non-work zone crashes had a higher percentage of crashes occurring under adverse weather, lighting, and road surface conditions.

Approximately 50 percent of work zone related crashes occurred on a *two-way not divided highway* and almost 25 percent occurred on a *two way divided highway with a positive median barrier*. The *first harmful event location* was the *roadway* in both work zone and non-work one crash situations, followed by the *roadside*. *Outside the roadway*, work zone crashes occurred 4.07 percent of the time, and 6.34 percent of the time for non-work zone crashes. Work zone and non-work zone crashes were almost identical with 68.38 and 68.521 percent of the most harmful events occurring as a *collision with a motor vehicle in traffic*. A higher percentage of work zone crashes occurred with a *parked motor vehicle* as well as with a *pedestrian*. Motorists were more likely to hit an *animal, tree, guardrail, and utility pole* in a non-work zone crash as opposed to a work zone crash. 158 work zone crashes (2.42 percent) had a *most harmful event* of collision

*with work zone maintenance equipment* along with 59 non-work zone related crashes (0.02 percent).

#### 4.1.2.1 VEHICLE LEVEL CHARACTERISTICS

The vehicle level characteristics were analyzed for vehicular involvement within the work zone and non-work zone crashes and can be found in Table 8. There were 6,244 vehicles involved in work zone related crashes and 299,485 in non-work zone crashes from 2007 to 2009 in Massachusetts according to queried data from the Warehouse. The *most harmful event* field had very similar results to the *first harmful event* despite the latter being a crash level variable. *Collision with a motor vehicle in traffic* was extremely similar (69.62 and 69.76 percent for work zone and non-work zone crashes). Work zone crashes had a higher percentage of *collisions with pedestrians* and *parked motor vehicles* while non-work zone crashes had a higher percentage of *trees, animals, guardrails, and utility poles*. *Work zone maintenance equipment* was the *most harmful event* for 2.03 percent of work zone crashes and 0.02 percent of non-work zone crashes.

The *driver contributing code* was a combination of both selections available for input in the crash report form. *No improper driving* was recorded as the most common for work zone and non-work zone crashes (51.59 and 50.52 percent). *Inattention* was a higher cause of crashes in work zones and *failure to yield right of way* was higher for non-work zone crashes.

Passenger cars were involved in 66.85 percent of work zone crashes and 70.71 percent of non-work zone crashes. Heavy vehicles were involved in 8.04 percent of work zone crashes and only 3.78 percent of non-work zone crashes. A higher percentage of *motorcycles* and lower percentages of *light trucks* were involved in work zone crashes rather than non-work zone crashes.

Vehicles in work zone crashes and non-work zone related crashes were *traveling straight ahead* prior to the crash 50.75 and 54.46 percent of the time, respectively. Crashes in work zones occurred 23.38 percent and 19.60 percent of the time in non-work zones when the vehicle involved was *slowing or stopped*.

**TABLE 8 Vehicle Level Crash Analyses**

	Work Zone Related Citations		Non-Work Zone Related Citations	
	Freq.	(percent)	Freq.	(percent)
<b>Most Harmful Event</b>				
Motor Vehicle In Traffic	4,347	(69.62)	208,934	(69.76)
Parked Motor Vehicle	485	(7.77)	19,338	(6.46)
Pedestrian	169	(2.71)	4,198	(1.40)
Cyclist	37	(0.59)	2,629	(0.88)
Animal-Deer	29	(0.46)	3,949	(1.32)
Animal-Other	5	(0.08)	662	(0.22)
Moped	2	(0.03)	105	(0.04)
Workzone Maintenance Equipment	127	(2.03)	61	(0.02)
Railway Vehicle	1	(0.02)	45	(0.02)
Other Movable Object	85	(1.36)	2,398	(0.80)
Unknown Movable Object	11	(0.18)	380	(0.13)
Curb	56	(0.90)	2,729	(0.91)
Tree	124	(1.99)	11,069	(3.70)
Utility Pole	164	(2.63)	11,930	(3.98)
Light Pole or Other Post/Support	76	(1.22)	3,600	(1.20)
Guardrail	130	(2.08)	8,080	(2.70)
Animal-Deer	79	(1.27)	1,983	(0.66)

Moped	48	(0.77)	1,570	(0.52)
Embankment	18	(0.29)	1,991	(0.66)
Highway Traffic Sign Post	22	(0.35)	1,020	(0.34)
Overhead Sign Support	3	(0.05)	95	(0.03)
Fence	21	(0.34)	1,871	(0.62)
Mailbox	5	(0.08)	678	(0.23)
Impact Attenuator/Crash Cushion	7	(0.11)	190	(0.06)
Bridge	11	(0.18)	423	(0.14)
Bridge Overhead Structure	8	(0.13)	273	(0.09)
Other Fixed Object	103	(1.65)	5,686	(1.90)
Unknown Fixed Object	13	(0.21)	333	(0.11)
Ran Off Road Right (sequence)	0	(0.00)	0	(0.00)
Ran Off Road Left (sequence)	0	(0.00)	0	(0.00)
Cross Median/Centerline (sequence)	0	(0.00)	0	(0.00)
Overturn/Rollover	39	(0.62)	2,366	(0.79)
Equipment Failure (sequence)	0	(0.00)		(0.00)
Fire/Explosion	0	(0.00)	36	(0.01)
Immersion	1	(0.02)	42	(0.01)
Jackknife	0	(0.00)	36	(0.01)
Cargo/Equipment Loss or Shift	3	(0.05)	83	(0.03)
Separation of Units (sequence)	0	(0.00)		(0.00)
Downhill Runaway (sequence)	0	(0.00)		(0.00)
Other Non-Collision	13	(0.21)	622	(0.21)
Unknown Non-Collision	2	(0.03)	80	(0.03)
<b>Driver Contributing Code (Combined Categories)</b>				
No Improper Driving	2,730	(51.59)	137,583	(50.92)
Exceeded Authorized Speed Limit	83	(1.57)	4,554	(1.69)
Disregarded Traffic Signs, Signals, Road Markings, Failed to Yield Right of Way	163	(3.08)	7,139	(2.64)
Failed to Yield Right of Way	293	(5.54)	19,669	(7.28)
Followed Too Closely	235	(4.44)	10,636	(3.94)
Made an Improper Turn	54	(1.02)	3,267	(1.21)
Driving Too Fast for Conditions	119	(2.25)	8,941	(3.31)
Wrong Side or Wrong Way	30	(0.57)	1,437	(0.53)
Failure to Keep in Proper Lane or Running Off Road	214	(4.04)	12,369	(4.58)
Operating Vehicle in Erratic, Reckless, Careless, Negligent, or Aggressive Manner	175	(3.31)	11,656	(4.31)
Swerving or Avoiding Due to Wind, Slippery Surface, Vehicle, Object, Non-Motorist in Roadway, etc.	82	(1.55)	4,905	(1.82)
Over-correcting/over steering	73	(1.38)	3,481	(1.29)
Glare	48	(0.91)	1,345	(0.50)

Physical Impairment	40	(0.76)	1,837	(0.68)
Emotional	5	(0.09)	402	(0.15)
Illness	17	(0.32)	941	(0.35)
History Heart/Epilepsy/Fainting	7	(0.13)	348	(0.13)
Visibility Obstructed	78	(1.47)	2,626	(0.97)
Inattention	651	(12.30)	27,789	(10.28)
Distracted	104	(1.97)	4,430	(1.64)
Fatigued/Asleep	48	(0.91)	2,828	(1.05)
Operating Defective Equipment	25	(0.47)	1,025	(0.38)
Cellular Telephone	17	(0.32)	913	(0.34)
Fax Machine	0	(0.00)	19	(0.01)
Computer	0	(0.00)	16	(0.01)
On-Board Navigation System	1	(0.02)	49	(0.02)
Two-Way Radio	0	(0.00)	13	(0.00)
<b>Vehicle Configuration Code</b>				
Passenger Car	4,882	(66.85)	246,827	(70.71)
Light Truck	1,742	(23.85)	85,368	(24.46)
Motorcycle	92	(1.26)	3,685	(1.06)
Bus (>=15)	44	(0.60)	1,387	(0.40)
Bus (7-15)	29	(0.40)	636	(0.18)
Single Unit Truck (2 axles)	156	(2.14)	3,782	(1.08)
Single Unit Truck (3 or more axles)	57	(0.78)	898	(0.26)
Truck/Trailer	89	(1.22)	2,173	(0.62)
Tractor Trailer (Bobtail)	8	(0.11)	122	(0.03)
Tractor/Semi-Trailer	120	(1.64)	2,576	(0.74)
Tractor/Doubles	3	(0.04)	108	(0.03)
Tractor/Triples	1	(0.01)	41	(0.01)
Unknown Heavy Truck	77	(1.05)	1,374	(0.39)
Motor Home/Recreational	3	(0.04)	94	(0.03)
<b>Vehicle Action Prior to Crash</b>				
Travelling Straight Ahead	3,933	(50.75)	204,674	(54.46)
Slowing Or Stopped	1,804	(23.28)	73,648	(19.60)
Turning Right	278	(3.59)	14,047	(3.74)
Turning Left	475	(6.13)	32,178	(8.56)
Changing Lanes	198	(2.55)	5,327	(1.42)
Entering Traffic Lane	248	(3.20)	11,380	(3.03)
Leaving Traffic Lane	39	(0.50)	2,231	(0.59)
Making U-Turn	32	(0.41)	1,162	(0.31)
Overtaking/Passing	59	(0.76)	2,408	(0.64)
Backing	310	(4.00)	9,456	(2.52)
Parked	374	(4.83)	19,285	(5.13)

#### 4.1.3 CMV Specific Analysis

Improved CMV specific data was queried from the Warehouse for January 1, 2007 to December 31, 2009. Analysis was done on this data as laid out in the methodology with the available improved data.

##### 4.1.3.1 General CMV Crash Data

The improved data queried from the Warehouse was divided into several categories. There were 14,662 individuals involved in 6,987 CMV crashes with 7,026 CMVs. There were a total of 4813 injuries, 254 (5.28 percent) in work zone and 4559 (94.72 percent) in non-work zone related crashes. Ten percent of 100 total fatalities occurred in work zone related crashes. These can be found in Table 9.

**TABLE 9 General CMV Crash Data**

<b>Type of Crash</b>	<b>Frequency</b>
Individuals Involved	14,662
CMVs Involved in Crashes	7,026
Crashes Involving a CMV	6,987
Number of Injuries	4,813
Number of Work Zone Related Injuries	254
Number of Non-Work Zone Related Injuries	4,559
Number of Fatalities	100
Number of Work Zone Related Fatalities	10
Number of Non-Work Zone Related Fatalities	90
Number of Work Zone Related Crashes	293
Number of Non-Work Zone Related Crashes	6,696*

\* does not include blanks

#### 4.1.3.2 CRASH LEVEL CMV DATA

Crash level data was examined next. This included road and weather characteristics and is presented in Table 10. A higher percentage of non-work zone related CMV crashes occurred in *daylight* than non-work zone related (83.46 percent versus 79.73 percent). This was the opposite for *dark*, *lighted* or *unknown* lighting (11.86 percent versus 10.31 percent). Non-work zone related CMV crashes occurred 56.75 percent of the time in *two-way not divided highways* and 45.94 percent of the time for work zone related crashes. The CMV related work zone crashes occurred 39.58 percent of the time in *two-way positive median barrier* but only 22.84 percent of the time for non-work zone related crashes, a 16.7 percent difference. Work zone related CMV crashes occurred with *no adverse weather conditions* 89.45 percent of the time and 79.65 percent of the time for non-work zone related CMV crashes; this is a 9.8 percent difference. *Dry* road surface conditions also had about a ten percent difference, with work zone related CMV crashes occurring 81.60 percent of the time and 71.05 percent of the time for non-work zone related CMV crashes.

**TABLE 10 Crash Level CMV Data Analyses**

	Work Zone Related Crashes		Non-Work Zone Related Crashes	
	Freq. (percent)	Freq. (percent)	Freq. (percent)	Freq. (percent)
<b>Light Condition</b>				
Daylight	232 (79.73)	5,358 (82.46)		
Dark-Not Lighted	14 (4.81)	321 (4.94)		
Dark-Lighted	33 (11.34)	658 (10.13)		
Dark-Unknown Roadway Lighting	1 (0.34)	12 (0.18)		
Dawn	5 (1.72)	149 (2.29)		
Dusk	6 (2.06)	124 (1.91)		
<b>Road Surface Condition</b>				
Dry	235 (81.60)	4,709 (71.05)		
Wet	39 (13.54)	1,182 (17.83)		
Water (standing, moving)	0 (0.00)	5 (0.08)		
Snow	3 (1.04)	432 (6.52)		
Slush	1 (0.35)	75 (1.13)		
Ice	3 (1.04)	195 (2.94)		
Sand, Mud, Dirt, Oil or Gravel	7 (2.43)	30 (0.45)		
<b>Trafficway</b>				
Two-Way Not Divided	130 (45.94)	3,720 (56.75)		
Two-Way Divided, Unprotected Median	21 (7.42)	907 (13.84)		
Two-Way Positive Median Barrier	112 (39.58)	1,497 (22.84)		
One Way Not Divided	20 (7.07)	431 (6.58)		
<b>Weather Condition</b>				
No Adverse Condition	229 (89.45)	4,239 (79.65)		
Rain	23 (8.98)	564 (10.60)		
Sleet, Hail	1 (0.39)	89 (1.67)		
Snow	2 (0.78)	393 (7.38)		
Fog	0 (0.00)	16 (0.30)		
Blowing Sand, Soil, Dirt, or Snow	0 (0.00)	15 (0.28)		
Severe	1 (0.39)	6 (0.11)		

#### 4.1.3.3 Vehicle Level CMV Crash Data Analysis

Vehicle level characteristics in CMV crashes were examined and the results can be found in Table 11. Work zone crashes occurred with *no improper driving* more often than non-work zone related crashes (57.69 versus 54.44 percent). Work zone related crashes also occurred more often when a vehicle was *following too closely* (6.32 versus

4.54 percent). *Failure to keep in proper lane or running off road* occurred most often in non-work zone related crashes. *Inattention* caused a similar percentage of crashes in and out of work zones, around ten percent. *A collision motor vehicle in traffic* was the most harmful event for 86.41 percent of non-work zone related CMV crashes and 80.03 percent of work zone related crashes. *A collision with a parked motor vehicle* was the most harmful event in 6.60 percent of work zone crashes and 4.27 percent of non-work zone related crashes.

**TABLE 11 Vehicle Level CMV Crash Analyses**

<b>Driver Contributing Code</b>	<b>Work Zone Related Crashes</b>		<b>Non-Work Zone Related Crashes</b>	
	<b>Freq.</b>	<b>(percent)</b>	<b>Freq.</b>	<b>(percent)</b>
No Improper Driving	210	(57.69)	5,661	(54.44)
Exceeded Authorized Speed Limit	3	(0.82)	107	(1.03)
Disregarded Traffic Signs, Signals, Road Markings, Failed to Yield Right of Way	13	(3.57)	378	(3.63)
Failed to Yield Right of Way	17	(4.67)	708	(6.81)
Followed Too Closely	23	(6.32)	472	(4.54)
Made an Improper Turn	1	(0.27)	169	(1.63)
Driving Too Fast for Conditions	5	(1.37)	207	(1.99)
Wrong Side or Wrong Way	6	(1.65)	68	(0.65)
Failure to Keep in Proper Lane or Running Off Road	10	(2.75)	436	(4.19)
Operating Vehicle in Erratic, Reckless, Careless, Negligent, or Aggressive Manner	9	(2.47)	267	(2.57)
Swerving or Avoiding Due to Wind, Slippery Surface, Vehicle, Object, Non-Motorist in Roadway, etc.	4	(1.10)	131	(1.26)
Over-correcting/over steering	1	(0.27)	84	(0.81)
Glare	6	(1.65)	96	(0.92)
Physical Impairment	2	(0.55)	37	(0.36)
Emotional	0	(0.00)	2	(0.02)
Illness	1	(0.27)	33	(0.32)
History Heart/Epilepsy/Fainting	2	(0.55)	11	(0.11)
Visibility Obstructed	5	(1.37)	112	(1.08)

Inattention	37	(10.16)	1,111	(10.68)
Distracted	5	(1.37)	154	(1.48)
Fatigued/Asleep	1	(0.27)	64	(0.62)
Operating Defective Equipment	2	(0.55)	65	(0.63)
Cellular Telephone	1	(0.27)	18	(0.17)
Fax Machine	0	(0.00)	1	(0.01)
On-Board Navigation System	0	(0.00)	7	(0.07)
<b>Most Harmful Event</b>				
Motor Vehicle In Traffic	461	(80.03)	11,482	(86.41)
Parked Motor Vehicle	38	(6.60)	568	(4.27)
Pedestrian	17	(2.95)	101	(0.76)
Cyclist	0	(0.00)	31	(0.23)
Animal-Deer	0	(0.00)	5	(0.04)
Animal-Other	0	(0.00)	10	(0.08)
Moped	0	(0.00)	1	(0.01)
Workzone Maintenance Equipment	19	(3.30)	6	(0.05)
Railway Vehicle	0	(0.00)	3	(0.02)
Other Movable Object	4	(0.69)	120	(0.90)
Unknown Movable Object	1	(0.17)	15	(0.11)
Curb	0	(0.00)	23	(0.17)
Tree	1	(0.17)	111	(0.84)
Utility Pole	1	(0.17)	120	(0.90)
Light Pole or Other Post/Support	2	(0.35)	39	(0.29)
Guardrail	4	(0.69)	124	(0.93)
Animal-Deer	1	(0.17)	29	(0.22)
Moped	2	(0.35)	25	(0.19)
Embankment	2	(0.35)	36	(0.27)
Highway Traffic Sign Post	0	(0.00)	3	(0.02)
Overhead Sign Support	3	(0.52)	5	(0.04)
Fence	0	(0.00)	12	(0.09)
Impact Attenuator/Crash Cushion	4	(0.69)	3	(0.02)
Bridge	2	(0.35)	62	(0.47)
Bridge Overhead Structure	5	(0.87)	91	(0.68)
Other Fixed Object	1	(0.17)	49	(0.37)
Unknown Fixed Object	0	(0.00)	3	(0.02)
Overturn/Rollover	5	(0.87)	117	(0.88)
Fire/Explosion	0	(0.00)	1	(0.01)
Jackknife	0	(0.00)	14	(0.11)
Cargo/Equipment Loss or Shift	1	(0.17)	22	(0.17)
Other Non-Collision	1	(0.17)	49	(0.37)
Unknown Non-Collision	1	(0.17)	8	(0.06)

#### 4.1.4 Citation Data Analysis

Analyses on the queried crash-citation dataset were completed according to the methodology outlined above. The results were then aggregated into an array of facts and tables and reported below. The results were divided into several sections: generalized work zone citation analysis, citation rankings, general crash variables, event related crash variables, and driver contributing code variables.

##### 4.1.4.1 Generalized Work Zone Citation Analysis

As previously noted, the Warehouse was queried with the intent of identifying variables associated with work zone crashes. The results of a generalized work zone and non-work zone crash and citation analysis are reported in Table 12. From 2007 to 2009 there were 398,604 police reported crashes along Massachusetts roadways, in which 58,387 of those crashes resulted in at least one citation being issued. A total of 103,734 citations were issued for the 58,387 crashes. Scaling down, 1,320 of the 58,387 crashes, with 2,118 associated citations, were reported by police as work zone related on the crash report form. This yielded an average of 1.59 citations per work zone crash, less than the 1.77 citations per reported non-work zone related/unknown crash. The majority of work zone related crashes (60.23 percent) had a single citation written, while approximately half of the crashes unrelated to work zones (50.55 percent) had multiple citations as seen in Figure 11. This difference was statistically significant ( $p < 0.01$ ). The number of non-work zone related crashes with citations decreased 10.9 percent from 2007 to 2008 but increased 20.9 percent in 2009 to above 2007 levels. Contrarily, the work zone related crashes with citations increased every year. Over 170 different citations were issued for

non-work zone crashes over the three year period, but only approximately 30 different citations were issued in work zones.

**TABLE 12 Work Zone And Non-Work Zone Related Crash And Citation Basic Analysis**

	2007		2008		2009		Total	
	Non-WZ	WZ	Non-WZ	WZ	Non-WZ	WZ	Non-WZ	WZ
# of Crashes With Citations	18,828	331	17,189	389	21,463	600	57,480	1,320
# Citations Issued	29,710	540	33,780	550	38,126	1028	101,616	2,118
# Crashes With Only One Citation Issued	12,091	206	4,528	248	11,801	341	28,420	795
# Crashes With Multiple Citations Issued	6,737	125	12,661	141	9,662	259	29,060	525
Average # of Citations Issued Per Crash	1.58	1.63	1.97	1.41	1.78	1.71	1.77	1.59
Average # of Citations Issued for Crashes With Multiple Citations	2.62	2.67	2.31	2.14	2.72	2.65	2.55	2.49
# of Types of Citations Issued	156	18	170	22	171	26	-	-

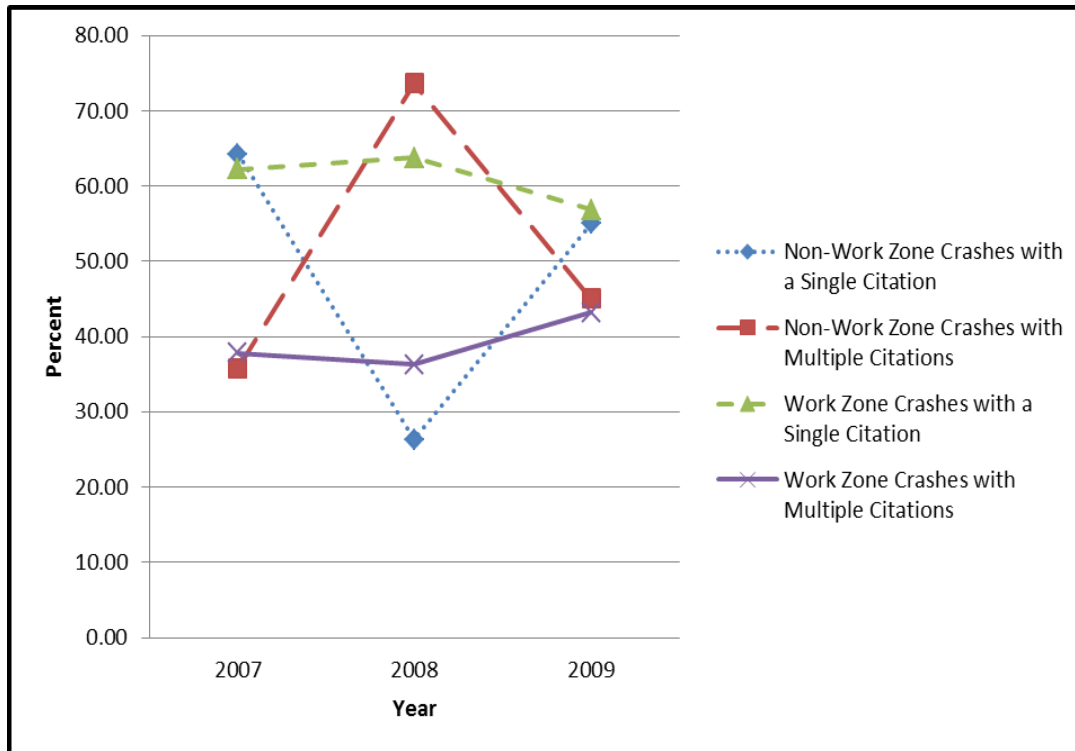

**Figure 11 Percentages of crashes with single and multiple citations.**

#### 4.1.4.2 Citation Rankings

Citations for both work zone and non-work zone crashes were analyzed according to the methodology described above. A ranking of the most common citations for all work zone and non-work zone crashes was also completed and can be seen in Table 13.

**Table 13 Citation Analyses By General Crash Variables For Work Zone Versus Non-Work Zone Crashes**

Ranking	Work Zone Related Citations		Non-Work Zone Related Citations		P-Value
	Freq.	(percent)	Freq.	(percent)	
State Highway Violation	376	(17.75)	10264	(10.10)	0.0000
Lane Violation	219	(10.34)	12186	(11.99)	0.0204
Leave Scene Prop	129	(6.09)	6726	(6.62)	0.3325

<b>Damage</b>					
Driving to Endanger	112	(5.29)	6763	(6.66)	0.0123
Failure to Stop	112	(5.29)	6164	(6.07)	0.1372
Operator Unlicensed	103	(4.86)	6339	(6.24)	0.0094
Other	1067	(50.38)	53174	(52.33)	0.0753
<b>Time</b>					
00:00-04:00	338	(15.96)	16257	(16.00)	0.0964
04:01-08:00	200	(9.44)	9059	(8.91)	0.3991
08:01-12:00	439	(20.73)	14903	(14.67)	0.0000
12:01-16:00	394	(18.60)	21083	(20.75)	0.0159
16:01-20:00	315	(14.87)	24027	(23.64)	0.0000
20:00-23:59	432	(20.40)	16287	(16.03)	0.0000
<b>Alcohol and Drug Related Time</b>					
00:01-04:00	72	(37.31)	2848	(31.60)	0.0919
04:01-08:00	8	(4.15)	483	(5.36)	0.4579
08:01-12:00	18	(9.33)	385	(4.27)	0.0007
12:01-16:00	3	(1.55)	819	(9.09)	0.0003
16:01-20:00	22	(11.40)	1919	(21.29)	0.0009
20:01:23:59	70	(36.27)	2559	(28.39)	0.0165
<b>Injury</b>					
No Injury	1196	(60.83)	59198	(61.67)	0.4495
Possible Injury	331	(16.84)	15030	(15.66)	0.1550
Non-Incapacitating Injury	328	(16.68)	16426	(17.11)	0.6171
Incapacitating Injury	102	(5.19)	4844	(5.05)	0.7759
Fatal Injury	9	(0.46)	490	(0.51)	0.7447
Known Injury	770	(39.17)	36790	(38.33)	0.4490
<b>Manner of Collision</b>					
Single Vehicle Crash	490	(23.42)	30710	(30.97)	0.0000
Rear-End	841	(40.20)	26332	(26.55)	0.0000
Angle	361	(17.26)	25782	(26.00)	0.0000
Sideswipe, Same Direction	277	(13.24)	8062	(8.13)	0.0000
Sideswipe, Opposite Direction	44	(2.10)	3405	(3.43)	0.0009
Head On	73	(3.49)	4616	(4.65)	0.0121
Rear to Rear	6	(0.29)	265	(0.27)	0.8648

The citations were ranked according to the most commonly issued for both work zone and non-work zone categories. Seventeen of the top 20 citations issued from 2007-

2009 existed in both the work zone and non-work zone related citations. The citations that did not exist in the top 20 of the other set are: *traffic safety violation, keep right no view, and no registration/license in possession* for non-work zone related citations; *refuse obey police, impeding operation, and seatbelt violation* for work zone related citations. *State highway violations* (citation number 720900OT) were the top ranked citations for work zone citations and second for non-work zone ( $p < 0.001$ ). *Lane violations* (citation number 89 4 A) were the most common citations for non-work zone citations and second for work zones ( $p = 0.0204$ ). *Leave scene of property damage crash* (citation number 90 24 PD) was third for each and not significantly different. The top six citations for non-work zone and work zone related categories contained the citations and both made up almost 50 percent of the total citations (47.67 percent and 49.62 percent respectively). Citations ranked as number seven and eight for non-work zones were *speeding* and *right of way at intersection* violations, whereas the violations for work zones in the same ranks were both alcohol related. Alcohol and drug related citations make up over seven percent of total citations for both work zone and non-work zone related citations.

#### 4.1.4.3 General Crash and Citation Data

The general crash and citation data analyzed carried out as described in the methodology can be found in Table 13, above. Below are notable findings for each of the crash report form fields chosen for citation analysis.

##### 4.1.4.3.1 Time

The amount of citations issued per time period and divided between the three years of the dataset are shown in Table 14. The distribution of time periods between

08:01 and 23:59 were significantly different ( $p < 0.05$ ) for work zone and non-work zone crashes and the distributions between 00:00 and 08:00 were not. Crashes between 08:01 and 12:00 had the highest frequency of citations for work zones. For non-work zone related citations, *state highway violations* (citations number 720900 OT) were issued most often from 08:01 to 20:00. *Lane Violations* (citation number 89 4A) were the most common from 20:01 to 08:00. For work zone related citations, *state highway violations* were the most common citations written from 04:01 to 23:59. *Lane violations* were the most common between 00:00 and 04:00.

**TABLE 14 Citations For Work Zone And Non-Work Zone Crashes Sorted By Time**

<b>Work Zone Related Citations</b>	<b>00:00-04:00</b>	<b>04:01-08:00</b>	<b>08:01-12:00</b>	<b>12:01-16:00</b>	<b>16:01-20:00</b>	<b>20:01-23:59</b>
2007	97	67	120	109	60	87
2008	95	45	119	106	87	98
2009	146	88	200	179	168	247
<b>Total</b>	338	200	439	394	315	432
<b>Non-Work Zone Related Citations</b>						
2007	4,563	3,001	4,778	6,318	6,827	4,223
2008	5,309	3,152	5,105	6,727	7,943	5,544
2009	6,385	2,906	5,020	8,038	9,257	6,520
<b>Total</b>	16,257	9,059	14,903	21,083	24,027	16,287

#### 4.1.4.3.2 Alcohol Related Citations

The distribution of alcohol and drug related citations were significantly different for the same time periods as all citations ( $p < 0.05$ ). The amount of alcohol or drug related citations were the highest for both work zone and non-work zone citations between 20:01 and 04:00 as seen in Figure 12. During that time period, work zone

related citations had a higher percentage of alcohol and drug related citations than non-work zone citations. Between 12:01 and 20:00, non-work zone citations had the most alcohol related citations.

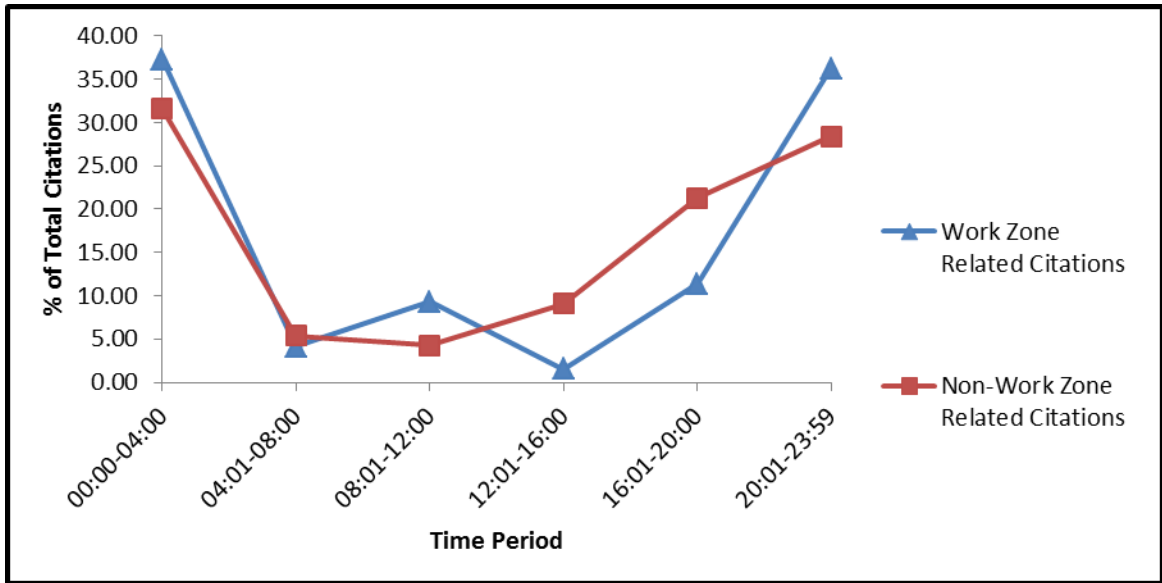

FIGURE 12 Percent of total citations that are alcohol or drug related.

#### 4.1.1.3.3 Injuries

*Injury status description* rather than *injury status code* was chosen for this analysis as explained previously. Results were calculated and analyzed using known injury status, which includes *possible injury*. None of the injury status descriptions varied significantly between work zone and non-work zone citations (see Table 13). There were nine total work zone related citations written for crashes where a fatality occurred over the three year period and 490 non-work zone citations. Uncertainty was fairly common in the injury status field with 7.15 percent of the citations for work zone

related crashes having an invalid, unknown, or unreported injury status and 5.54 percent for non-work zone citations, a significant difference ( $p < 0.001$ ).

### *Manner of Collision*

Table 13 shows that every field in *manner of collision*, except *rear to rear crashes* varied significantly between work zone and non-work zone citations ( $p < 0.05$ ). The most citations were written for *rear-end* work zone crashes (40.20 percent) and *single vehicle* non-work zone crashes (30.97 percent). There was a lower percentage of *angled crash* citations written for work zones than non-work zone, 17.26 and 26 percent respectively. For *rear end crashes*, *state highway violations* were most common citations for both work zone and non-work zone crashes, followed by *operator unlicensed* and *leave scene of property damage crash*. Also, for *single vehicle crash* citations in both work zone and non-work zone crashes, *lane violations* were most common, followed by *driving to endanger*, *speeding* and *leave scene of property damage crash*. Unlike many other categories, *state highway violations* were not within the top five ranked citations for single vehicle crashes.

#### 4.1.4.4 Work Zone and Non-Work Zone Citation Analysis by Selected Event Related Variables

Once the basic crash variables were analyzed, event related crash variables were analyzed similarly. These included categories and associated fields from the crash report form such as *first harmful event location*, most harmful event, and *vehicle action prior to crash*. The results of these analyses are reported below and in Table 15.

**TABLE 15 Citation Analysis By Event Related Variables For Work Zone Versus Non-Work Zone Crashes**

	Work Zone Related Citations		Non-Work Zone Related Citations		P- Value
	Freq.	(percent)	Freq.	(percent)	
<b>Vehicle Action Prior to Crash</b>					
Travelling Straight Ahead	1325	(65.85)	63,824	(65.54)	0.7667
Slowing or Stopped	142	(7.06)	4,803	(4.93)	0.0000
Turning Right	55	(2.73)	4,157	(4.27)	0.0007
Turning Left	124	(6.16)	10,354	(10.63)	0.0000
Changing Lanes	135	(6.71)	3,430	(3.52)	0.0000
Entering Traffic Lane	97	(4.82)	3,825	(3.93)	0.0416
Leaving Traffic Lane	20	(0.99)	1,853	(1.90)	0.0030
Making U turn	18	(0.89)	678	(0.70)	0.2908
Overtaking/Passing	54	(2.68)	2,004	(2.06)	0.0509
Backing	38	(1.89)	2,312	(2.37)	0.1561
Parked	4	(0.20)	146	(0.15)	0.5758
<b>First Harmful Event Location</b>					
Roadway	1671	(85.65)	70,372	(74.55)	0.0000
Median	40	(2.05)	2,024	(2.14)	0.7759
Roadside	107	(5.48)	9,219	(9.77)	0.0000
Shoulder-Paved	26	(1.33)	1,230	(1.30)	0.9092
Shoulder-Unpaved	29	(1.49)	2,248	(2.38)	0.0100
Shoulder-Travel Lane	3	(0.15)	193	(0.20)	0.6228
Outside Roadway	75	(3.84)	9,107	(9.65)	0.0000
<b>Most Harmful Event</b>					
Motor Vehicle in Traffic	1,225	(65.75)	56,063	(61.06)	0.0000
Parked Motor Vehicle	152	(8.16)	6,534	(7.12)	0.0835
Guardrail	84	(4.51)	3,471	(3.78)	0.1032
Pedestrian	71	(3.81)	1,487	(1.62)	0.0000
Utility Pole	66	(3.54)	5,576	(6.07)	0.0000
Work zone Maintenance Equipment	43	(2.31)	25	(0.03)	0.0000
Tree	36	(1.93)	5,265	(5.73)	0.0000
Other Fixed Object	32	(1.72)	2,777	(3.02)	0.0011
Animal-Deer	30	(1.61)	62	(0.07)	0.0000
Overturn/Rollover	20	(1.07)	1,391	(1.51)	0.1215
Light Pole or other Post/Support	12	(0.64)	1,482	(1.61)	0.0009
Curb	10	(0.54)	1,330	(1.45)	0.0010
Other	82	(4.40)	6,358	(6.92)	0.0000

#### 4.1.4.4.1 Vehicle Action Prior to Crash

The majority of citations were written for crashes in which the vehicle was *travelling straight ahead* for both work zone and non-work zones as seen in Table 15 and did not vary significantly. *Slowing or stopped actions* were second highest within citations for work zones (7.06 percent) and *turning left* (10.63 percent) was second for non-work zones, both significant differences. *State highway violations* were the most commonly issued for work zone citations where the vehicle was *travelling straight ahead*, followed by *lane violations*, *driving to endanger*, *speeding*, and *operator unlicensed*. In non-work zone crashes where the vehicle was *travelling straight ahead*, *lane violations* were the most common, followed by *state highway violations*, *driving to endanger*, *leave scene property damage*, and *failure to stop*.

#### 4.1.4.4.2 First Harmful Event Location

The highest percentage of citations was written for crashes where the *first harmful event location* was on the *roadway*: 85.65 percent for work zone crashes and 74.55 percent for non-work zones (see Table 15). However, these numbers were significantly different ( $p < 0.001$ ). *State highway violations* followed by *lane violations* were the most common citations written. *Failure to stop* and *operator unlicensed* were the third and fourth ranked citations for non-work zones, and the opposite for work zone citations. The *roadside* was the second highest location for both work zone and non-work zone crashes varied significantly ( $p < 0.001$ ). Crashes *outside the roadway* had 3.84 percent of work

zone related citations and 9.65 percent for non-work zone related. These also differed significantly ( $p < 0.001$ ).

#### 4.1.4.4.3 Most Harmful Event

In both the work zone and non-work zone crashes, the *most harmful event* was collision with a *motor vehicle in traffic*, with 65.75 and 61.06 percent, respectively as seen in Table 15. This difference was however statistically significant ( $p < 0.001$ ). The most commonly issued citations for work zone crashes where *collision with a motor vehicle in traffic* was the *most harmful event* were *state highway violations, lane violations, failure to stop, and operator unlicensed*. For non-work zone crashes, the most common citations were *state highway violations, failure to stop, lane violations, and operator unlicensed*. The second highest *most harmful event* for both work zones and non-work zone related crashes is collision with a *parked motor vehicle* which was not significantly different. The *most harmful event* of *collision with work zone maintenance equipment* had 2.31 percent of work zone related citations and 0.03 percent of non-work zone citations, statistically significant ( $p < 0.001$ ). For non-work zone citations, hitting a *pedestrian* was ranked seventh with 1.62 percent. Contrarily, work zone related citations ranked *pedestrians* as the fourth highest with 3.81 percent, more than twice the percentage.

#### 4.1.4.5 Driver Contributing Code

The driver contributing code analysis was completed separately with both fields combined, as previously discussed in the methodology and seen in Table 16. *Operating a*

*vehicle in erratic, reckless, careless, negligent or aggressive manner* had the highest amount of citations issued for both work zones and non-work zones with 16.43 and 19.93 percent respectively, a significant difference ( $p < 0.001$ ). Following were *failure to keep in proper lane or running off road, inattention, and failed to yield right of way* but all fields were not significantly different between work zones and non-work zone. In work zones, 65 citations (3.86 percent) were issued in crashes in which there was *no improper driving* in a work zone, whereas 4188 (4.03 percent) citations were written in the same instance for non-work related crashes. These numbers did not differ significantly.

**TABLE 16 Citation Analyses By Driver Contributing Code For Work Zone Versus Non-Work Zone Crashes**

	Work Zone Related Citations Freq. (percent)		Non-Work Zone Related Citations Freq. (percent)		P-Value
<b>Driver Contributing Code (Combined Categories)</b>					
Operating Vehicle in Erratic Reckless, Careless, Negligent or Aggressive Manner	277	(16.43)	20,703	(19.93)	0.0004
Failure to Keep in Proper Lane or Running Off Road	186	(11.03)	10,817	(10.41)	0.4079
Inattention	180	(10.68)	10,717	(10.31)	0.6286
Failed to Yield Right of Way	170	(10.08)	9,873	(9.50)	0.4201
Disregarded Traffic Signs, Signals, Road Markings	162	(9.61)	6,846	(6.59)	0.0000
Followed Too Closely	136	(8.07)	6,360	(6.12)	0.0010
Other Improper Action	111	(6.58)	9,557	(9.20)	0.0002
Exceeded Authorized Speed Limit	84	(4.98)	5,706	(5.49)	0.3620
No Improper Driving	65	(3.86)	4,188	(4.03)	0.7164
Driving Too Fast for Conditions	60	(3.56)	4,750	(4.57)	0.0478
Physical Impairment	58	(3.44)	3,153	(3.03)	0.3362
Wrong Side or Wrong Way	40	(2.37)	1,838	(1.77)	0.0629
Made an Improper Turn	35	(2.08)	2,084	(2.01)	0.8395
Over-Correcting/Over-Steering	27	(1.60)	1,031	(0.99)	0.0127
Distracted	26	(1.54)	1,682	(1.62)	0.8049
Fatigued/Asleep	12	(0.71)	1,205	(1.16)	0.0873
Other	57	(3.38)	3,389	(3.26)	0.7856

#### 4.1.5 Crash Data Conclusion of Results

The crash, CMV, and citation data collected, analyzed and reported in the above sections followed the procedures outlined in the methodology. The results yielded both

surprising and unsurprising results which are discussed and concluded in Section 5 of this thesis.

## 4.2 Narrative Search

Two methods of narrative search were performed in accordance with the methodology. The first was an examination of a random sample of 100 of both work zone and non-work zone narratives and the second was a key word search of the narratives available electronically from a query of the UMass Safety Data Warehouse.

### 4.2.1 Double Blind Narrative Search

A random sample of 100 work zone related citations and 100 non-work zone related crash narratives were queried from the crash data set used in this analysis. A double blind test was performed for accuracy of results. Initially, 250 random narratives were read by the researcher and work zone related key words and phrases were chosen for analysis in the double blind test.

The chosen key words and phrases were:

- Arrow board
- Arrowboard
- Closed
- Closure
- Cone
- Coned
- Cones

- Construction
- Orange
- Road Work
- Work
- Worker
- Work Zone
- Zone

Of the 100 work zone related narratives explored, only 28 provided any indication of being work zone related which means 72 percent of the narratives searched did not indicate work zone involvement. Two of the work zone related narratives had words included in the search, but did not in fact indicate involvement. The average number of work zone related words included in the narratives that indicated work zone involvement was 2.81. The average number of times the words appeared in an individual narrative was 3.78. The list of words and the number of times they appeared in the 28 narratives are shown in Table 17. *Construction* was present 29 times and *zone* and *dump* were present 11 times. *Work* showed itself nine times. *Arrowboard* and *road* were not present in any of the narratives. New words were chosen to include in the second part of the analyses based on their presence in the work zone narratives. These words included barrel, barrels, repair, detail, dump, crew, steel plates, site and project.

**TABLE 17 Double Blind Narrative Search Results**

<b>Key Words</b>	<b>Number of Work Zone Related Narratives Containing Word</b>	<b>Number of Non-Work Zone Related Narratives Containing Word</b>
Construction	29	2
Zone	11	0
Dump	11	0
Work	9	2
Arrow Board	6	0
Coned	5	1
Cones	4	0
Barrel	4	0
Closure	3	0
Cone	3	0
Orange	3	2
Closed	2	0
Worker	2	0
Detail	2	0
Crew	2	0
Steel Plates	1	0
Repair	1	0
Barrels	1	0
Site	1	0
Project	1	0
Arrowboard	0	0
Road	0	0

None of the 100 non-work zone related narratives indicated work zone involvement, as one might expect. However, three of the narratives had the chosen work zone related terms. Those terms were coned, construction, orange, work, and steel plates. They were present seven times in the three narratives.

#### 4.2.2 Key Word Narrative Search

The second part of the narrative search involved a key word search of the crash narratives from the crashes queried from the Warehouse. The 398,604 crashes yielded 93,089 electronic narratives, 2,811 of which were marked as work zone related in the crash report form and 90,279 of which were marked as non-work zone related. The non-work zone related crash narratives were the data set included in this search. This key word narrative search was carried out in accordance with the methodology outlines in Section 2. The words searched and the results indicating work zone involvement and their associated discriminating power can be found in Table 18. The goal of the key word search was to randomly sample at least 30 narratives that showed up with a key word. Some key words yielded less than 30 hits, and therefore all were checked for work zone involvement. Some key words were also checked in more than 30 narratives.

**TABLE 18 Discriminating Power Of Work Zone Related Words**

Key Word	# of Narratives Containing Key Word	Work Zone Related/ Sample Size	Discriminating Power	
Steel Plate	1	1/1	100.00%	*
Construction Zone	38	25/30	83.33%	
Work Zone	23	14/23	60.87%	*
Road Work	10	6/10	60.00%	*
Construction	653	12/30	40.00%	
Set up	54	12/30	40.00%	
Coned	23	9/23	39.13%	*
Plow	722	11/30	36.67%	
Setup	25	9/25	36.00%	*
Closure	83	10/30	33.33%	
Cones	101	9/30	30.00%	
Set-up	11	3/11	27.27%	*
Barrels	64	7/30	23.33%	

Arrow Board	67	15/67	22.39%	
Project	25	4/25	16.00%	*
Cone	180	4/30	13.33%	
Detail	727	4/30	13.33%	
Dump	290	4/30	13.33%	
Dump Truck	151	4/30	13.33%	
Barrel	133	3/30	10.00%	
Engineer	37	2/37	5.41%	
Divert	59	3/59	5.08%	
Closed	3324	1/30	3.33%	
Crew	200	1/30	3.33%	
Orange	211	1/30	3.33%	
Repair	383	1/30	3.33%	
Road	31354	1/30	3.33%	
Safety	576	1/30	3.33%	
Site	1583	1/30	3.33%	
Work	2849	1/30	3.33%	
Worker	147	1/30	3.33%	
Advisory	24	0/24	0.00%	*
Arrowboard	6	0/6	0.00%	*
Back Up	590	0/30	0.00%	
Backup	133	0/30	0.00%	
Hot Box	1	0/1	0.00%	*
Manhole	23	0/23	0.00%	*
Paint	1061	0/30	0.00%	
Service	2795	0/30	0.00%	
Warning	3787	0/30	0.00%	
Zone	1316	0/30	0.00%	

\* Denotes sample size below 30

*Steel plate* had a discriminating power of 100 percent, which implies that every time the phrase was used, the crash was in fact a work zone related crash; however, there was only one narrative that yielded that phrase. *Construction zone* had a discriminating power of 83.33 percent, with a sample of 30. *Work zone* and *road work* were the next highest with 60.87 and 60.00 percent, and narrative amounts of 23 and 10, respectively.

*Construction* and *set up* followed with 40 percent discriminating power. They both had samples of 30. Close behind were *coned*, *plow*, and *setup*.

*Set up*, *setup*, and *set-up* all differed in their discriminating power, 40 percent, 36 percent, and 27.27 percent respectively. In that same respect, *coned*, *cones*, and *cone* all differed with 39.13, 30, and 13.33 percent. Barrels and *barrel* also differed greatly, with 23.33 and ten percent. *Dump* and *dump truck* were both 13.33 percent.

In reading the non-work zone related narratives and checking them for work zone involvement, several qualitative observations were made. The majority of the narratives that indicated work zone involvement did so in one of two ways: either from rear-ending another vehicle in a queue formed due to a work zone backup, or vehicles quickly and unsafely changing lanes due to a work zone lane closure. Other commonly found situations involved crashes during sanding or plowing. In most instances, more than one work zone related key word was found in a non-work zone related narrative that indicated work zone involvement. In addition, there were many situations that were commonly found to include work zone related words but did not related to work zone involvement, such as *closed* in *case closed*, *crew* in *EMS crew*, or *arrow board* and *cones* when referring to a set up in response to a crash.

The words with over 20 percent discriminating power were then used to determine the number of narratives that showed multiple work zone related word or phrase hits. The discriminating power of 20 percent was chosen because if three words show up in a narrative with 20 percent discriminating power, it stands to reason that there is a 60 percent probability that that narrative was actually work zone related. A total of 14 words were chosen. Any narratives with less than two work zone related words, under

the 2.81 determined in the previous section, were removed from the search pool. The narratives with higher numbers of key words were checked for work zone involvement. The number of individual words that presented themselves in the narratives and the percentage of narratives that indicated work zone involvement can be found in Table 19.

**TABLE 19 Key Words In Narrative Search**

<b>Number of Chosen Key Words</b>	<b>Number of Narratives</b>	<b>Number Indicating Work Zone Involvement</b>	<b>Percent Work Zone Related</b>	<b>Cumulative Percent</b>
6	1	1	100.00	100.00
5	1	1	100.00	100.00
4	7	5	71.43	77.78
3	20	13	65.00	68.97
2	129	19/30	63.33	66.10

Only two narratives were found with five or six key words and both indicated work zone involvement. Five out of seven narratives were found that indicated work zone involvement with four key words, meaning that 77.78 percent of narratives with 4 words or more indicated work zone involvement. At least two key words were found in 158 narratives; this resulted in a 66.10 percent discriminatory rate.

### 4.3 Conflict And Event Studies

A conflict and event study methodology was developed and carried out as outlined in the methodology above. Qualitative and quantitative observations were made for 14 work zone setups. They included multiple types of lane and shoulder closures,

several types of work, lengths, and weather conditions. A description of the work zones can be found in Table 20.

**TABLE 20 Work Zone Descriptions**

	<p style="text-align: center;"><b>Work Zone 1</b></p> <p>Utility work done on rightmost lane on collector. 1 lane out of 4 closed immediately after CVS driveway. Work zone was about 1 mile long. Taper about 25 feet long feet long. 3 signs leading up to work zone on north approach. North bound lanes were unaffected. There were no flaggers or police present. 8 workers and 4 trucks. Overcast, about 80 degrees</p>
	<p style="text-align: center;"><b>Work Zone 2</b></p> <p>Bridge work on south side of bridge on collector. The bridge is 2 lanes in the Eastbound Direction (one for straight and right turns and one for left turns) and one in the westbound direction. The Westbound lane was closed entirely and the traffic was diverted into the left turn lane of the eastbound. The work zone is about 1/4 mile long. Police officer and cruiser present. Cones and barrels, and arrow boards used. Tapers present on each approach. Eastbound through traffic was unaffected. Left turn bay shortened for only one vehicle. 7 workers, multiple trucks and equipment. 2 signs leading to work zone on eastbound side, and 3 signs on westbound side.</p>



### **Work Zone 3**

One utility truck on northbound side of collector fixing a telephone pole. 5 cones, one worker. Only 15 minute setup. Lane open to traffic due to wide lanes.



### **Work Zone 4**

About ½ mile of work on side of local road and at intersection. 2 lane road with no markings. No lanes were closed. Equipment lined the road and often drove or swung into the road. 9 workers, one police officer who directed traffic occasionally. Cones lined the street. Slow speeds, around 25 miles per hour. Sunny, about 80 degrees.



### **Work Zone 5**

Resurfacing about 1 mile of a collector. All 4 lanes redirected with cones into 3 lanes. 1 for eastbound, 1 for westbound, and 1 for construction traffic. Police officer stood between the construction and eastbound lane directing traffic and closing or opening the construction lane for paving vehicles. Also directed traffic for vehicles coming out of side road. There were no signs leading up to the work zone. Several traffic backups due to paving. Sunny, about 80 degrees.



**Work Zone 6**

Road work at the intersection on a collector. Several vehicles and equipment. 5 workers. 2 officers directing traffic. 1 left during observations. Traffic alternated passing through the work zone. The signal at the intersection to the west was flashing yellow. Traffic travelled about 35 miles per hour on roadway. Sunny, about 75 degrees.

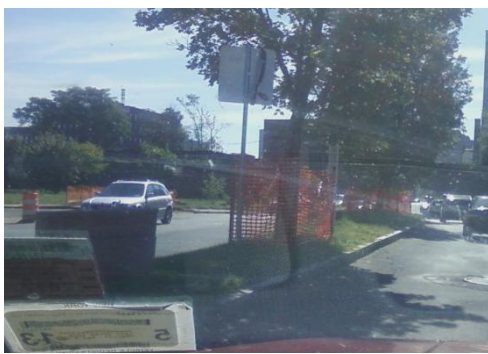

**Work Zone 7**

Road work over one mile long on urban collector. One lane of two closed in each direction. No merging required. Work zone ahead signs on all side streets leading up to the work zone. Cones and barrels lined street. No apparent work being performed at time of observation. Multiple signals were within the work zone. Sunny, about 75 degrees.



**Work Zone 8**

Road patching on local road. Mobile down about a mile and a half of street. 1 vehicle with a driver and worker, 1 police officer. Steady movement, driving down the road and tarring then moving to next. No cones or barrels. 1 sign at entrance of road. Sunny, about 80 degrees. Very little traffic, moving at about 25 miles per hour.



**Work Zone 9**

Cones, barrels and equipment in the middle of main collector at intersection with side street. Affected traffic flow in all directions. Eastbound side of road was dug up and filled. No signs led up to the area on any approach. Speeds were about 40 miles per hour. Sunny, about 80 degrees.



### **Work Zone 10**

Work on side of road around uphill bend on local road. Two officers directing traffic with 1 cone. One lane closed around bend. Very difficult to see officer around first bend. 2 workers, 2 trucks. One sign on each approach leading to the work zone. Sunny, about 80 degrees



### **Work Zone 11**

Bridge work on south side of local road with lane closed. Two police officers directing traffic. Barrels and cones used. 3 signs, 2 on one west approach, 1 on east approach. Multiple pieces of equipment and trucks. About 9 workers. Sunny, about 70 degrees.



### **Work Zone 12**

Same setup as above but on north side of street. Work had been going on one day. Cloudy, cold and rainy, about 60 degrees. Very difficult to see.

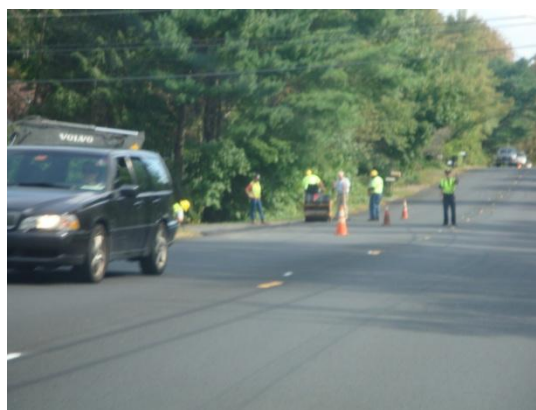

### **Work Zone 13**

Repaving on rural collector and entrance to cross street. 3 workers, 1 pavement roller and a truck and trailer. One lane closed using 2 cones. 2 police officers directing traffic. One officer left and cones were moved halfway through. One sign on west approach. Sunny, about 70 degrees.



#### **Work Zone 14**

Constructing double roundabout off-road. Entire road is lined with cones and barrels. Construction had been going on for several months. During observations, road was dug up by two workers and an excavator and then left that way. No officer or flagger directing traffic. Signs leading up to construction area. Rainy and warm, about 75 degrees

The characteristics from each work zone were organized into a matrix of characteristics that can be found in Table 21 and 22. Table 21 provides characteristics of the roadway and Table 22 provides characteristics unique to the work zone itself. All values and observations are approximations. The conflicts and events observed at each of the 14 work zones were recorded and are presented in Table 23 below.

**TABLE 21 Roadway Location Characteristics Matrix**

Work Zone ID	Length Of Observation (mins)	Observation Time	Speed Limit	Approx. Hourly Volume	Approx. Heavy Vehicle Percentage	Weather	Average Speed on Roadway
1	60	2:45-3:45	40	1190	2.5	Rainy, overcast warm	N/A
2	60	12:00-1:00	30	928	4	Sunny warm	N/A
3	15	2:55-3:10	30	360	2	Sunny warm	N/A
4	45	2:00-2:45	25	201	0.5	Sunny warm	N/A
5	70	12:20-1:30	35	625	2.2	Sunny warm	N/A
6	60	2:15-3:15	35	625	2.4	Sunny warm	N/A
7	30	11:50-12:20	30	879	5.4	Sunny warm	N/A
8	30	11-11:30	25	122	3.5	Sunny warm	N/A
9	20	12:33-12:52	40	777	3.1	Sunny warm	26.2
10	60	12:45-1:45	25	952	4	Sunny warm	35.6
11	60	2:00-3:00	40	434	N/A	Sunny cool	36.8
12	60	10:35-11:35	40	400	N/A	Rainy, overcast cool	36.8
13	60	2:10-3:10	40	288	4.3	Sunny cool	43.4
14	60	1:04-2:04	40	808	3	Rainy, overcast cool	42.2

**Table 22 Work Zone Specific Characteristics Matrix**

Work Zone ID	Work Zone Description	Police	Workers	Equipment	Moving Equipment	Change in Work Zone Setup During Observations	Work Zone Operating More Than One Day	Signs Leading to Work Zone	Cones/Barrels	At Intersection	Approx. Length of Work Zone	Taper Present	Average Speed at Work Zone Entrance
1	Utility work, 1/4 lanes closed	0	8	6	N	N	Y	2	Cones	N	1 mi	Y	N/A
2	Bridge work, 1/3 lanes closed and redirected	1	7	4	N	N	N/A	4	Cones	N	1/4 mi	Y	N/A
3	Streetlight bulb replacement, side of road	0	1	1	N	N	N	N	Cones	N	<1/4 mi	N	N/A
4	Underground Utility Work, on side of road	1	9	4	Y	Y	N/A	3	Cones	N	1/2 mi	N	N/A
5	Repaving, 4/4 redirected lanes	1	N/A	0	Y	Y	Y	N	Cones	N	>1 mi	N	16.6
6	Digging and cutting pavement in road, 2/2 lanes redirected	2	5	6	N	N	N/A	N	Cones, Barrels	Y	< 1/4 mi	N	N/A
7	Misc. road work, 1/4 lanes closed	0	N/A	0	N	N	Y	>10	Barrels	N	> 1 mi	N	22.4
8	Patching on one side of road	1	2	2	Y	Y	N/A	1	N	N	1 mi	N	16.8
9	No work, cones blocking broken roadway	0	0	0	N	N	N/A	N	Cones	Y	< 1/4 mi	N	22.5
10	Digging on side of road, 1/2 lanes closed	2	2	2	Y	N	N/A	2	Cone (1)	N	1/4 mi	N	21.7
11	Bridge work, 1/2 lanes closed	2	9	9	N	N	N/A	3	Barrels	N	1/4 mi	N	24.1
12	Bridge Work, 1/2 lanes closed	2	9	9	N	N	Y	3	Barrels	N	1/4 mi	N	19.9
13	Repaving Intersection, 1/2 lane redirected	2	3	3	Y	Y	N/A	1	Cones	Y	<1/4 mi	N	22.8
14	Large-scale construction, 2/2 lanes redirected	0	2	2	Y	Y	Y	2	Cones, Barrels	Y	1/2 mi	N	26.16

**TABLE 23 Observed Conflicts And Events**

<b>Work Zone ID</b>	<b>Traffic Infractions*</b>	<b>Speed Related</b>	<b>Merge Related</b>	<b>Equipment Related</b>	<b>Setup Related</b>	<b>Age Related</b>	<b>Other</b>	<b>Serious</b>	<b>Notes</b>
1	NO	7	13	NO	NO	2	NO	4	All serious conflicts involved on vehicle cutting off another at fast speeds when merging into the open lane. Both vehicles then either almost hit each other or travelled into the work zone side by side with one vehicle in the oncoming traffic lane. 2 older drivers were unable to merge effectively and had to stop and wait for someone to let them into the left lane.
2	13	10	NO	3	NO	NO	NO	NO	Drivers seemed confused at the setup, especially when large machinery was moving . Intersection was often backed up. 4 drivers ran red lights, 9 drivers snuck out to make a left turn at the end of the yellow cycle. One cone was knocked over.
3	NO	4	NO	NO	NO	NO	NO	NO	4 vehicles were speeding and braked heavily upon noticing the setup.
4	NO	1	NO	6	NO	NO	NO	NO	Drivers seemed confused when the officer was directing traffic. All of the of the equipment related events occurred when the backhoe was moving down or swinging out into the road
5	NO	NO	NO	2	1	1	NO	NO	2 cones were knocked over. Older driver did not know where to stop or go and had to be directed by officer.

6	1	2	NO	2	4	1	1	1	Busses had a very difficult time navigating the setup, backed up traffic and drove onto the curb. An older driver stopped and went several times upon reaching the work zone, causing driver confusion on other approaches. The serious event occurred when one driver sped towards the work zone, followed by a second. The first vehicle sped through the work zone and the second slammed on the brakes and swerved to the right to avoid hitting the police officer and work crew.
7	1	NO	NO	1	NO	NO	NO	NO	One vehicle was confused and swerved several times before going through the correct lane in the work zone.
8	NO	NO	NO	NO	NO	NO	NO	NO	No conflicts, very low volume, local road, only 20 minutes of observation
9	NO	29	NO	NO	4	NO	NO	1	The serious event occurred when a vehicle was driving too fast and slammed on its brakes, causing the two vehicles behind it to swerve and brake heavily to miss the first vehicle. 4 times a vehicle went around the wrong side of the group of cones and barrels, into the oncoming traffic lane to continue down the road or turn into the side road.
10	NO	10	NO	NO	2	NO	NO	NO	9 vehicles were reprimanded by the officer to slow down. One vehicle slammed on breaks, was motioned by the police officer to slow down, and then entered the work zone in the oncoming traffic lane. Another driver moved to the oncoming traffic lane within the work zone and left on the wrong side.
11	NO	NO	NO	NO	NO	NO	NO	NO	The work zone seemed to work effectively and efficiently. No conflicts or events were observed in the eh hour period.

12	NO	1	NO	NO	NO	NO	NO	1	Many vehicles seemed confused about whether and/or where to stop for the work zone. The serious event occurred when a driver was driving extremely fast and seemed distracted. The driver did not slow down for the setup or police officer until the vehicle was about 20 feet away. The vehicle swerved and the officer had to jump out of the way to narrowly avoid being hit.
13	NO	NO	NO	1	NO	NO	NO	NO	The equipment related event occurred when a vehicle heading towards the work zone had to stop short when the pavement roller moved out into the street immediately in front of the vehicle. The officer was not directing traffic at that point.
14	NO	4	NO	NO	7	NO	1	1	When work was being performed across the road, 6 vehicles swerved around each other to navigate the area. The serious event occurred when two vehicles on two different approaches waited for the equipment to move and then both decided to go at the same time, narrowly missing a collision. There was no officer directing traffic. While a worker was spreading material on the roadway, a vehicle waiting grew impatient and sped around the worker, startling and narrowly missing him.

\*NO = Not Observed

#### 4.3.1 Traffic Infractions

The traffic infractions observed were primarily U-turn and red light related. Work Zone 2 saw 13 drivers either run straight through the red signal or “sneak” and make a left turn as the signal turned red. The work zone and intersection were very congested and often backed up; many of the violators had been waiting several minutes to go through the intersection. The infractions in Work Zones 6 and 7 were due to drivers making U-turns directly before or after the work zone.

#### 4.3.2 Speed Related Conflicts And Events

Every speed related conflict or event occurred when a driver was driving too fast, came upon the work zone, and had to brake heavily. Work Zone 9 had the most speed related events. There was no officer directing traffic, no workers there, and no signage leading up to the cones, barrels, and equipment.

#### 4.3.3 Merge Related Conflicts And Events

The merge related conflicts and events were unseen in any work zone other than Work Zone 1. The taper cone was very short and the vehicles moved at high speeds. Often a driver would be in the left lane, which was the correct one for entering the work zone, and a vehicle would speed through the right lane, cutting off the slower driver in the left lane who was properly entering the work zone.

#### 4.3.4 Equipment Related Conflicts And Events

Equipment related conflicts and events occurred when a piece of equipment was moved or driven into the road and a driver was required to make evasive maneuvers to avoid the equipment. This occurred with a backhoe six times in Work Zone 4. Although a police officer was there to direct traffic, there still seemed to be much confusion as to where a driver should go when the backhoe was in the road. Several times, a vehicle pulled forward to pass the equipment, only to back up again and wait.

#### 4.3.5 Setup Related Conflicts And Events

The setup related conflicts and events occurred when a vehicle entered or exited the work zone in the wrong lane. This also included difficulty navigating a work zone. Work Zone 5 had a tractor trailer that tried to pull out of the side road and was unable to do so with the cone setup. It had to maneuver itself for several minutes, blocking traffic, to make the turn. Three busses in Work Zone 6 had trouble driving around the work setup. As described above, Work Zone 9 had no signs or officers directing traffic, and four times vehicles entered the wrong side of the road when they wanted to go straight or turn into the side road, potentially creating a conflict with opposing traffic. Work Zone 10 had two situations where, even with a police officer directing traffic, they entered or left the work zone in the oncoming traffic lane. There was only one cone to indicate the presence of a lane change. Six vehicles in Work Zone 14 had trouble navigating around each other at the intersection while work was being performed.

#### 4.3.6 Age Related Conflicts And Events

All age related conflicts and events involved older drivers. It is important to note that not all older drivers were involved with a conflict or event; the ones recorded were specifically noticed as a driver who may have been over the age of 65 and was involved in a conflict or event. More may have occurred, but due to observation difficulties, they may not have been recorded. Likewise for younger drivers, an age related conflict or event would have been recorded if it seemed the driver involved in one was younger than 25, however, none were observed. The older driver conflicts that were observed involved an older driver being confused about where to stop, merge or enter the work zone.

#### 4.3.7 Other Conflicts And Events

The other conflicts and events were observed in situations that did not fit into any other category. One example is Work Zone 14 which had a driver, who was waiting for a worker to finish spreading material, grow impatient and speed away, startling the worker. Work Zone 6 had one driver stop and speak to the officer directing traffic for several minutes, thus holding up traffic for several minutes.

#### 4.3.8 Serious Conflicts And Events

Five work zones were observed with serious conflicts and events. All but one involved high speeds. Work Zone 1 saw issues with speed and merging combining to create a potential for a serious crash with head on traffic. Two of the serious conflicts, in Work Zones 6, and 9 involved a driver stopping short after driving too fast, requiring other vehicles to stop short and swerve to avoid a collision. The serious conflict in Work

Zone 12 involved a distracted driver driving too fast and almost colliding with a police officer. Work Zone 14 had a serious conflict when two drivers pulled out from their respective approaches and almost collided.

#### 4.3.9 Conflict and Event Results Summary

The findings that resulted from the conflict and event studies performed on 14 work zones presented much material for review and examination. A discussion of the results and drawn conclusions is presented in Section 5 of this thesis.

## CHAPTER 5

### CONCLUSIONS AND RECOMMENDATIONS

In an effort to explore the nature of a work zone crash to improve work zone safety, three major topics of work zone safety were explored within the scope of this research: crash data analysis, crash narrative searches using the definition of a work zone, and conflict and event studies. The data were analyzed in accordance with the methodology outlined in Section 3 and the results of which were presented in Section 4. Based upon the results, several interesting conclusions were developed which provide insight into the differences between work zone and non-work zone related crashes. The sections below present conclusions for each of the three major threads of research carried out herein. Subsequent to those sections is a series of recommendations regarding future research that would have the potential to expand upon, or add to, the existing research effort.

#### 5.1 Data Analysis

This study used police reported crash and citation data between 2007 and 2009.. The data was analyzed in three ways, crash data analyses, CMV specific data analyses, and analyses of citation data in connection with crash data. The data queried from the Warehouse was used to make connections between the differences in work zone and non-work zone related crashes.

### 5.1.1 Crash Analysis

The crash analysis was completed using police reported crash report form data queried from the Warehouse.

In the generalized crash data breakdown, every category examined, crashes and occupants for all crashes, work zones, and non-work zone related crashes decreased from 2007 to 2009, except for work zone related crashes and occupants, which increased from 2008 to 2009 by approximately 1,000 crashes and 2,000 occupants. This result was admittedly unexpected, and no rational explanation has yet to be identified that may have contributed to the increase.

Within the crash level analysis, crash report form fields were analyzed for work zone involvement and three categories were checked for statistical significance. The crash time categories were all statistically significant. It is worth noting that the *injury status description* was not significantly different between any of the levels of the category. However, the *manner of collision* between all but one category was significantly significant. These two results are somewhat contradictory in that when injury severities are similar, it may be assumed that the manner of collision would be as well.

As expected, the crash frequency for work zone and non-work zone related crashes differed in the winter more than the summer. More specifically, the percentage of crashes in *December, January, February, and March* differed between the two types. This finding can be attributed to the increased absence of work zones in the winter

months within the Commonwealth of Massachusetts. *Light conditions* did not appear to have a significant impact on the percentage of work zone or non-work zone related crashes. This was not the case for *weather* and *road conditions*, in which both *clear weather* and *dry* road surface conditions had an overrepresentation of work zone related crashes of about seven percent. The change in driving conditions within work zones could possibly provide an explanation for a higher percentage of work zone related crashes in normal driving conditions than non-work zone crashes. A higher percentage of non-work zone crashes occurred on a *two-way divided road with a positive median barrier* for work zone crashes, but a higher percentage of non-work zone related crashes occurred on a *two-way, not divided roadway*. This was not unexpected, because a positive median barrier in a work zone could provide a smaller lane width, therefore increasing the chances for a crash.

One startling result of the data analysis was the enormous jump in work zone crashes that involved school busses. About 24 percent of work zone crashes involve *school busses*, yet only about one percent of non-work zone related crashes involved a school bus. It is recommended that further research be completed to address this result; however one initial theory may be the proximity of the school bus related and work zone related fields on the crash report form and the relatively uniform consistency in coding the crashes as non-work zone related.

The *first harmful event location* and *first harmful event* were similar enough between work zone and non-work zone related crashes. *Collision with a parked motor vehicle* was higher for work zone rather than non-work zone crashes, but that makes sense because there are probably more parked work vehicles in obtrusive positions found

around a work zone than along a roadway. One interesting examination of the data showed 59 non-work zone related crashes that had a first harmful event of a *collision with workzone maintenance equipment*. None of the available narratives gave any indication of work zone involvement. All crashes involves hitting equipment that was not involved in an active work zone, for example, a cone falling off of a truck that a vehicle swerved to miss. It was determined that it is probable that all of the crashes marked as such were properly labeled.

The vehicle level analysis looked at the most harmful event which was similar for work zone and non-work zone crashes. *Collision with a parked motor vehicle* was higher for work zone than non-work zone crashes. Again, *collision with work zone maintenance equipment* was found 87 times, but the explanation is the same as the *first harmful event* above. *Driver contributing code* yielded higher crash frequencies for non-work zone related crashes for *failed to yield right of way*. This was unexpected because of the prevalence of work zone related crashes that were found in the narrative searches to have been caused by improper lane changes during a merge. What was expected however, was the higher percentage of slowing or stopping crashes that were work zone related than non-work zone related for the same reason. The *vehicle configuration code* showed an overrepresentation of heavy vehicles in work zone crashes, which is in part why the . CMV specific analysis was warranted. Further research should be completed with respect to the association of the crash report form data fields and the types of work zones they are involved in. With further exploration into that topic, it could be determined what types of crashes occur in which types of work zones and this could lead to insight in remediating work zone crashes. Several specific crash fields should be examined in

detail as well, for example, the extremely high crash frequency of busses within work zones.

#### 5.1.2 CMV Specific Analysis

The CMV data was queried from improved crash data from within the UMass Safety Data Warehouse. These crashes were analyzed according to crash level or vehicle level fields.

Within the crash level analysis, a higher percentage of non-work zone related crashes occurred in *daylight* than work zone related crashes. This was the opposite from the generic crash analysis. A higher percentage of CMV crashes occurred in work zones in all *dark* situations. Like the general crash analysis, CMVs in work zones had about ten percent more crashes and non-work zones in dry conditions. Also like the general crash data analysis, there are a higher percentage of crashes in non-work zones when there is *rain, snow, or slush* on the ground which probably has to do with the decrease prevalence of work zones during those times. The ten percent more CMV crashes that occur during *no adverse weather conditions* show that normal weather conditions are enough to foster dangerous driving environments for CMVs in work zones. As above, a higher percentage of non-work zone crashes for CMVs occurs in the snow and rain.

The vehicle level analysis resulted in a higher percentage of CMV crashes in work zones when the *driver contributing code* was *following too closely*. This is not surprising given the high amount of work zone crashes that occur in queues or when merging for work zones as well as the higher amount of time it takes a CMV to stop. The most harmful event code involving a *parked motor vehicle* occurred with a higher

percentage in work zones and is higher also than the numbers seen in the general crash data analysis. This too is reasonable because in work zones, the lanes are often tighter and it would be harder for a CMV to navigate around parked vehicles near the work zone. In addition, *collision with a motor vehicle in traffic* occurred more often in non-work zone crashes, which suggests that CMV related work zone crashes more commonly involve parked motor vehicles, pedestrians, or other non-moving objects. It is suggested that CMVs crashes should be examined further in detail to determine what type of work zones most commonly create more dangerous crashes than others.

### 5.1.3 Citation Analysis

This current research effort employed a combined data set of both crash and citation data in an effort to better identify the commonalities associated with work zone crash causation as compared with non-work zone related crashes. Other than the statistical comparison between all crashes and all citations, this study focused exclusively on crashes in which at least one citation was issued from 2007 through 2009 in Massachusetts. Several interesting findings were identified throughout the investigation, providing insight into the differences between work zone and non-work zone related crashes and their associated citations. These identified differences raised almost as many questions as may have been answered.

The initial data analysis, which compared all crashes in the three year period in Massachusetts to all citations issued for crashes during the same period, showed significant differences across distributions. More directly, not a single category or field chosen for analysis had similar distributions for the two data sets. The implication of this

finding is that citations are not necessarily representative of work zone crash data at large. This is important to note considering citations are written based on crashes that occur. It should be considered in the future whether the differences are due to the crashes that occur in which citations are not written, or if the differences occur due to other factors.

An analysis of basic crash and citation numbers revealed some noteworthy results. In examining the 2009 data, the number of work zone crashes with citations in conjunction with the number of work zone crash citations, almost doubled from 2008 numbers. This much of an increase was not reflected in the crash numbers or the non-work zone citations. An explanation for this increase was not determined, but completed data from citations in more recent years may be able to provide justification. As expected, because of the higher number of citations issued in non-work zone crash situations, there was a higher amount of the types of citations issued. Another unexplained set of numbers are the 2008 non-work zone related citations. Every other data set had a larger number of crashes with only a single citation issued; however, the numbers flip for 2008 non-work zone related crashes, where only 26.34 percent are single citation crashes.

As may be expected, the same citations were present in both top 20 rankings of work zone and non-work zone citations. It was surprising that the *state highway violations* (citation number 720900 OT) differed significantly between work zones and non-work zones but *lane violations* (citation number 89 4A) and *leave scene prop damage* did not. Alcohol related citations ranked higher for within work zone citations. This became more apparent when examining the time and alcohol or drug related

citations. Logically, the most citations within work zones were written during typical work zone hours, while non-work zone citations occurred during the afternoon and evening. It follows that alcohol and drug citations would be more common during the nighttime hours, and this was supported by this research. As one would expect, work zones had a significantly higher percentage of alcohol and drug related citations at night. Drug and alcohol impaired drivers have a more difficult time navigating the roadway, and at night when it is harder to see and the roadway is altered or constricted due to a work zone, the chance for a crash can increase. These results support the notion that work zones become more dangerous when drivers using alcohol or drugs travel through them.

*Vehicle action prior to crash* indicates what the vehicle was doing prior to the crash. There were many differences between the types of citations written for work zone and non-work zone crashes. The vehicle actions varied greatly year to year as well.

The first harmful event location contained the same four citations for both work zone and non-work zone crashes for its most common field, roadway. This could be expected to coincide with the most common most harmful event, collision with a *motor vehicle in traffic*. The most harmful event explains what the officer believed caused the most injury or property damage in a crash. The same citations actually were present in the top four first harmful event location citations for the most harmful event of *collision with a motor vehicle in traffic*. When drivers collide with other vehicles in both work zones and non-work zones, they are often cited for the same violations. One of the most harmful events seemed conspicuously out of place. In the non-work zone related citations, 25 citations were written for crashes in which the most harmful event was marked on the crash report form as collision with *work zone maintenance equipment*. If

the collision involves work zone equipment, it stands to reason that the crash was work zone related. This indicates that either a mistake was made on the crash report form, or the officers felt the crash was, in actuality, not work zone related.

The *injury* and *manner of collision* fields yielded unexpected results. The injury status description gives the status of the highest injury in the crash, not necessarily the cited individual's injury. The manner of collision fields identify the manner in which the vehicles in the crash initially come together. As one would expect, and research has previously shown, in work zones, rear end crashes are more common, and angled crashes less so, so the crashes with citations would follow in the same manner. The numbers in this research support that assumption. It would then follow that the injury status would reflect these differences. However the analysis on injury status showed no significant change in any injury status field between work zone and non-work zone citations. This finding may provide evidence to suggest that similar types of crashes (i.e. rear-end versus rear-end) may be more severe when they occur within a work zone. Further isolation of these variables is recommended.

The *driver contributing codes* indicate which actions the officer felt may have contributed to the crash. This is closely related to the citations issued as well. It was therefore not remarkable that *operating vehicle in erratic, reckless, careless, negligent, or aggressive manner* would be the number one driver contributing code, followed by *failure to keep in proper lane or running off road*, which would coincide with a lane violation citation. Further research should be completed to examine the differences between driver contributing code for work zone crashes where a citation is and is not issued, to see if the *driver contributing code* has a different distribution, therefore

explaining why a citation was not issued in those crashes. Another interesting code found in this analysis was *no improper driving*. This could indicate the driver was not at fault for the crash, and therefore would not be cited in the crash. However, 3.86 percent and 4.03 percent of citations were issued for no improper driving in work zone and non-work zone related crashes respectively. Citations written in multiple work zone situations, like speed limits types of work zone setups should be explored further. To determine the types of citations written in different work zone setups could create a more complete database of work zone crash causes, both from physical and driver based factors.

#### 5.1.4 Potential Data Inaccuracies

As with all data analysis, inaccuracies in reporting and information sharing exist which create limitations for completing analysis of the data. Law enforcement officers claim that crash report forms are difficult to complete. For that reason, fields are often left blank or are improperly filled out. A change in the crash form in 2001 also created a learning curve, which skewed the data for a few years after due to confusion with the new fields. Another drawback to the CDS system is when fields are missing, information can be supplemented from the operator's report form which may contain biased information. This is commonly the case with PDO crashes rather than injury crashes. However, this is not a common case for CMV crashes because they require the police to fill out extra fields of information. Lack of CDS and SAFETYNET information sharing also creates inaccuracies in the data. When mistakes are found in the CMV data that the Truck Team investigates, the corrected information is passed to SAFETYNET but not back to the

RMV or CDS which creates a disparity in information that the sources contain. In addition, only a select number of fields in the crash report form were available for comparison between CMV specific crashes and all crash data due to the linkages available within the Warehouse. One distinct problem with the data analysis is that the work zone field may not be entirely accurate. This was addressed in the narrative sampling section of this study and can be further addressed through increased understanding of work zone crashes.

## 5.2 Narrative Search Analysis

The narrative search yielded several interesting findings from which resulting conclusions were drawn. In determining the accuracy of the work zone related field in the Massachusetts crash report form, this research was able to use key words to determine the accuracy of the field for a sample of narratives. Through this discovery, the definitions of work zones that were commonly mislabeled were brought to light.

### 5.2.1 Random Sample Search

The search of 100 random work zone and non-work zone related narratives, as marked in the crash report form, yielded both expected and unexpected results. Of the 100 work zone related narratives, only 28 gave indication that a work zone was involved. This startled the researchers, as they felt that if an officer marked a positive in the work zone field, they would be sure to write about its presence in the narrative. The 76 percent of the 100 narratives that did not indicate work zone involvement also did not include

work zone related words. The words that were present in the narratives that indicated work zone involvement were not surprising, with *construction* and *zone* being the highest. *Dump* was also a very common work zone related word. Also unsurprising was the amount of work zone words found in the narratives that indicated involvement. The average number of times a word was found in each of the 28 work zones was 2.81, showing that when a work zone was mentioned, it usually used several words to describe the situation. As expected, none of the 100 non-work zone related narratives indicated work zone involvement. However, three of the narratives showed false positives, where a work zone related word showed up but the narratives did not give any indication of the work zone. This was understandable due to the narratives describing vehicles being registered to construction companies, arrow boards and cones being deployed in response to crashes, and emergency medical service crews helping crash victims, among others. The words found, both commonly in work zone related narratives, and uncommonly in non-work zone related narratives, support the thought that certain key words can be used to identify work zone related crashes using crash narratives. However, these words cannot be used as the only determining factor in establishing work zone involvement as can be seen by the 72 percent of work zone related crash narratives that did not include any work zone related words.

### 5.2.2 Narrative Key Word Search

The narrative word search used words found in the previous step, as well as knowledge of work zones and other narrative searches to choose words to indicate work zone involvement. The amount of times a word was found in a narrative marked as non-

work zone related was used to determine the discriminating power of that word. In order to have statistical significance, where possible, samples of 30 were used. It is important to note that the word and phrase search looked for that word in any form. For example, if *cone* was searched for, the results yielded *cone*, *cones*, *coned*, as well as *deaconess*. This was done to be able to determine the discriminating power of the single word *cone*, as well as specifically, *cones*, or *coned*.

The discriminating power of each word varied greatly. For example, *steel plate* had a discriminating power of 100 percent, but only one narrative was found containing that phrase, so the researchers were unable to validate that result. The phrase *construction zone* had the next highest discriminating power at 83.33 percent. This validates the results from the 100 random narratives searched in the step above, which showed both construction and zone occurring most often. *Work zone* and *road work* were the following highest with about 60 percent. This makes sense because the phrases, like *construction zone*, all explicitly indicate there was a work zone present. All of the above mentioned phrases had a discriminating power of over 50 percent. The highest discriminating power of a single word was 40 percent for *construction*. It was very interesting to note that spelling had a high impact on indicating work zone involvement. *Setup* was spelled three different ways for the narrative search; *setup*, *set up*, and *set-up*. *Set up* had the highest discriminating power, followed by *setup* and *set-up*. This was similar for *coned*, *cones*, *cone* and *closure*, *closed*, where some spellings had a much higher discriminating power than others. *Back up*, and *backup*, which were found to be common causes of work zone related crashes, both had a very low discriminating power

as did *zone*, which when combined with other word, has high discriminating power, but by itself, in a sample of 30, yielded no work zone related narratives.

Once the words were given a discriminating power, combinations of the words with over 20 percent were used to determine work zone involvement. Combinations of 5 and 6 words yielded 100 percent work zone involvement. It turned out that a combination of two or more work zone related words yielded over a 60 percent positive rate for work zone involvement. This coincides with the results from earlier where the 28 work zone related narratives had an average of 2.81 work zone related words. The future application of these findings is significant in that potential exists for creating an improved fashion for identifying work zone crashes that were not labeled as such.

### 5.2.3 Commonly Mislabeled Work Zone Narratives

Because each individual narrative in the sample was read and work zone involvement was determined, it quickly became apparent which types of work zones were being mislabeled as non-work zone related. The majority of narratives that were marked as non-work zone related but indicated work zone involvement were from crashes resulting from vehicle rear-ending each other in a queue build up from a work zone. The second most common cause was from merging before the work zone as a result of a lane closure due to the work zone. Another common cause was crashes due to plowing or sanding activities. Other narratives involved drivers swerving or hitting construction barrels or cones. Other common narratives included crashes due to lane closures or redirects.

#### 5.2.4 Summary Of Narrative Search Results

When looking at the narrative search results, it is startling to see the amount of narratives that were marked as non-work zone related in the crash report form, but actually indicated work zone involvement. Over 528 narratives in total were checked for work zone involvement and over 98 of them indicated work zone involvement. That is an 18.6 percent involvement rate, in crashes that are not marked as involved in work zones. In addition to this, when compared to the idea that only 28 percent of the work zone related narratives in the 100 narrative sample showed involvement, the researchers could draw either of two conclusions: there are many more than 18.6 percent of incorrectly identified work zone related crashes, many of the work zone related crashes, according to the narratives, are actually not. Either way, it was determined that work zone narratives do not always mention work zones every time, and non-work zone related crashes are often mislabeled as such. Because not all crashes have a narrative, it can be assumed, according to the results of the analysis, that when at least two of the 14 key words and phrases are found in a narrative, there is over a 50 percent chance that that crash is work zone related. These results can be used to train officers in crash reporting to better improve new crash data sets.

#### 5.2.5 Challenges With Narrative Searches

Errors in the narratives could have skewed the results. Some narratives, due to data conversion or space errors did not contain all of the available text of the narrative. In addition, spelling errors could also have an impact when searching for key words and phrases.

### 5.3 Conflict And Event Studies

The purpose of the conflict and event studies was to develop a protocol for identifying surrogate measures of safety for work zones. The 14 work zones that were observed identified six categories of conflicts and events that occurred often within the work zone. Speed, equipment, and setup related conflict and events were common to several of the work zones, while the merge related conflicts and events only occurred in one work zone, as expected, it was the work zone that required high volumes of vehicles to merge at relatively high speeds. Serious conflicts were observed in five of the work zones, with one work zone encountering four. This was the same work zone with merge related conflicts. When comparing two similar work zones, like Work Zones 11 and 12, the only differences between the two involved the side of the bridge work was on, and weather. Work Zone 11 was observed in sunny warm weather with excellent visibility and had no observed conflicts or events of any kind during the entire hour. On the other hand, Work Zone 12, with almost exactly the same setup, had one speed related event, and one serious event that almost resulted in an officer being hit. This work zone was observed on a cloudy misty day with very low visibility.

It became apparent that the factors that contribute to work zone conflicts and events could be recorded and analyzed to determine which situations are more dangerous than others. Further research is recommended to continue to collect work zone information. The Conflict and Event Table, Table 23 can be used as a basis for determining the types of conflicts observed at work zones. More work zones should be observed, for at least an hour as done in this study, with multiple setups. By examining Work Zone 1 that required vehicles to merge, and the higher number of serious conflicts

that was associated with it, as opposed to the work zones that did not require a merge could potentially be the reason for the higher number of serious conflicts. That work zone also had the highest observed hourly volume, although work zone 10, 7, and 2 had similar volumes. Further data collection of roadways with merges and high volumes should be undertaken to determine whether the serious conflicts were due to high volumes, high speeds, the short distance merge, or a combination of factors. Work Zones 6, 9, and 12 also had a serious conflict. One was in poor weather, one involved speed and one involved impatience of drivers. All of these seemed to be isolated incidents in the 14 work zones observed, but could potentially be a common factor in other similar work zones.

In conclusion, the each work zone presented a different setup, volume, speed, etc. Although these findings provide an initial step forward, caution should be employed given the limited scope and size of the current data set. An immediate suggestion is to collect more data and use the factors identified herein to complete a regression analysis to determine which factors lead most commonly to conflicts and events within work zones and therefore could lead to more dangerous situations for drivers. In turn this regression analysis could be used to determine what types of changes could be made to work zones that match certain characteristics in order to make them safer.

The benefits associated with the successful completion of the research effort described herein provide several significant contributions to the current practices of work zone safety analyses. The results of this research provide a better understanding of the work zones and the crashes that occur as a result. This is important to provide valuable insight into how a work zone can be set up to minimize negative safety effects. The

literature review provides a better understanding the nature of the problem, the standards and guidelines already in place, and the research efforts that have been made to understand the problem. After analyzing the general work zone, CMV specific data, and citation data, this research provides insight into current crash causes and trends. The crash narrative examination examines the definition of a work zone and shows deficiencies in the crash reporting process to help police be more able to accurately fill out crash report forms. The conflict and event study shows that conflict and event studies can be carried out to determine the factors and causes of work zone crashes and can lead to widespread usage of surrogate measures for improving work zone safety. Overall, this research provides a better understanding of specific work zone crash topics whose study was determined to be imperative at the onset of this research in the overarching research goal identifying and addressing issues related to work zone safety as well as the three research objectives.

#### 5.4 Further Research

Although this research provides a step forward in completing the research analysis strategies for work zone and related crashes, there is need for further research. Further analysis should be completed using crash data and citation data in combination to determine the factors most commonly present in work zone crashes. The narratives show that the work zone related field in the crash report form can commonly be wrong. Further research should be aimed at developing potential training in and around identification of work zone crashes. If the officers are trained to use the definition of a

work zone as laid out by ANSI and the FHWA, they will more likely be able to accurately describe a work zone related event. They can also be asked to write a narrative more thoroughly if a work zone is involved for easier identification. The non-work zone marked narratives that actually indicate work zone involvement can be analyzed with the fields in the crash report form to discover trends in those specific work zone crashes; they could also be added to the data pool for all crashes to be further analyzed. In addition, more data can be collected for numerous work zones, especially multiple setups or work zones on continuing days, to provide data for the regression analysis to assist with developing surrogate measures of safety for work zones.

## APPENDICES

## APPENDIX A

### AMERICAN NATIONAL STANDARD MANUAL ON CLASSIFICATION OF MOTOR VEHICLE TRAFFIC DEFINITIONS

**Work Zone Accident:** A work zone accident is a motor vehicle traffic accident in which the first harmful event occurs within the boundaries of a work zone or on an approach to or exit from a work zone, resulting from an activity, behavior or control related to the movement of the traffic units through the work zone.

**Inclusions:**

- Collision and non-collision accidents occurring within the signs or markings indicating a work zone
- Collision and non-collision accidents occurring on approach to, exiting from, or adjacent to work zones that are related to the work zone, regardless of distance

**Examples:**

- 1.) An automobile on the roadway loses control within a work zone due to a shift or reduction in the travel lanes and crashes into another vehicle in the work zone
- 2.) A van in an open travel lane strikes a highway worker in the work zone
- 3.) A highway construction vehicle working on the edge of the roadway is struck by a motor vehicle in-transport in a construction work zone

- 4.) A rear-end collision accident occurs before the signs or markings indicating a work zone caused by vehicles slowing or stopped on the roadway because of the work zone activity
- 5.) A pickup in-transport loses control in an open travel lane within a work zone caused by a shift or reduction in the travel lanes and crashes into another vehicle down the road that had already exited the work zone
- 6.) A tractor trailer approaching an intersection strikes a pedestrian outside of the work zone. The accident is caused by a lack of visibility created by work zone equipment on the intersecting roadway
- 7.) A sport utility loses control and overturns on a roadway within a work zone due to a severe lane shift without any collision event

**Exclusions:**

- Accidents involving working motor vehicles that do not involve a motor vehicle in-transport
- An accident that occurs on the opposite side of a divided highway from the work zone, if the work zone is not signed on the accident side of the highway, and the accident is clearly unrelated to the work zone

**Examples:**

- 1.) Two motor vehicles performing work in a work zone collide
- 2.) A highway maintenance truck strikes a highway worker. Both are within the closed portion of the work site

3.) A utility worker repairing the electrical lines over the trafficway falls from the bucket of a cherry picker without being struck by a motor vehicle in-transport

**Work Zone:** A work zone is an area of a trafficway where construction, maintenance or utility work activities are identified by warning signs/signals/indicators, including those on transport devices (e.g., signs, flashing lights, channelizing devices, barriers, pavement markings, flagmen, warning signs and arrow boards mounted on the vehicles in a mobile maintenance activity) that mark the beginning and end of a construction, maintenance or utility work activity. It extends from the first warning sign, signal or flashing lights to the END ROAD WORK sign or the last traffic control device pertinent for that work activity. Work zones also include roadway sections where there is ongoing, moving (mobile) work activity such as lane line painting or roadside mowing only if the beginning of the ongoing, moving (mobile) work activity is designated by warning signs or signals.

**Inclusions:**

The following situations within the trafficway:

- Long-term stationary construction such as building a new bridge, adding travel lanes to the roadway, extending an existing trafficway, etc. (construction activity/work)
- Work involving moving activities such as striping the roadway, median and roadside grass mowing/ landscaping, pothole repair, snowplowing, lane line painting, etc., where

there are warning signs or signals marking the beginning of the moving work area

(Mobile maintenance activity/work)

— Short-term stationary work such as repairing/ maintaining electric, gas, water lines or traffic signals (Utility activity/work)

— Areas identified by signage as a work zone where the ongoing work activity has temporarily paused

**Exclusions:**

— Any private construction, maintenance or utility work outside the trafficway

— Any area of the trafficway where there is moving maintenance activity (e.g., roadside grass mowing/landscaping, pothole repair, snowplowing, lane line painting) without warning signs or signals

— Citizen removing snow from the trafficway as a neighborly gesture

— Area identified by signage, where the activity has not begun or is completed

**Working Motor Vehicle:** A working motor vehicle is a motor vehicle in the act of performing construction, maintenance or utility work related to the trafficway. This “work” may be located within open or closed portions of the trafficway and motor vehicles performing these activities can be within or outside of the traffic way boundaries.

**Inclusions:**

— Vehicle at work in a marked work zone

- Vehicle at work on the median, shoulder or roadside.
- Mobile maintenance convoy
- A law enforcement vehicle which is participating strictly in a stationary construction or mobile maintenance activity as a traffic slowing, control, signaling or calming influence

**Examples:**

- 1.) Asphalt roller working in a highway construction zone
- 2.) State highway maintenance crew mowing grass on roadside
- 3.) Utility truck performing maintenance on the power lines along the roadway
- 4.) A private excavating company contracted by the state digging the foundation for a new overpass

**Exclusions:**

- Vehicle performing a private construction/ maintenance activity
- Law enforcement vehicle performing other work activities, such as traffic stops, accident investigation, patrolling and traffic control, which is not related to construction, maintenance or utility work on the trafficway
- Vehicle performing a work activity other than highway construction, maintenance or utility work
- Construction, maintenance, utility vehicle while moving from one job site to another

**Examples:**

- 1.) An excavation company digging a foundation for a new building
- 2.) Garbage truck, delivery truck, taxi, emergency vehicle, tow truck, etc.

# APPENDIX B

## MASSACHUSETTS CRASH REPORT FORM

Commonwealth of Massachusetts																			
Date of Crash			City/Town			Motor Vehicle Crash Police Report		Speed Limit											
Time of Crash						Number Vehicles		Number Injured											
24HR								State Police <input type="checkbox"/>											
								Local Police <input type="checkbox"/>											
								MBTA Police <input type="checkbox"/>											
								Other <input type="checkbox"/>											
								Longitude											
<b>AT INTERSECTION:</b>					<b>LOCATION</b>					<b>NOT AT INTERSECTION:</b>									
Route# Direction Name of Roadway/Street										Route# Direction Address # Name of Roadway/Street									
At										Post [N S E W] of Mile Marker or Box Number									
Route# Direction Name of Intersecting Roadway/Street										Post [N S E W] of Intersecting Roadway/Street									
Also at Intersection with										Landmark									
Route# Direction Name of Intersecting Roadway/Street																			
Please Select One of the Following: <input type="checkbox"/> Vehicle 1 # Occupants <input type="checkbox"/> Hit/Run <input type="checkbox"/> Moped																			
License # _____ St _____ DOB/Age _____					Reg # _____ Reg Type _____ Reg State _____					Sex _____ Lic. Class _____ Lic. Restrictions _____ CDL Endorsement _____									
Operator _____					Owner _____					Veh Year _____ Veh Make _____ Veh Config _____									
Address _____					Address _____					City _____ State _____ Zip _____									
City _____ State _____ Zip _____					City _____ State _____ Zip _____					Insurance Company _____									
Vehicle Travel Direction: [N S E W] Responding to Emergency? _____					Event Sequence _____					Most Harmful Event _____									
Citation # (If Issued) _____					Driver Contributing Code _____					Underride/Override _____ Towed _____									
Violation 1: Ch _____ Sec _____ Violation 2: Ch _____ Sec _____					Underride/Override _____ Towed _____														
Violation 3: Ch _____ Sec _____ Violation 4: Ch _____ Sec _____					Underride/Override _____ Towed _____														
Please fill out for operator and all occupants involved										Please fill out for operator and all occupants involved									
Name (Last First Middle) _____					Address _____					DOB/Age _____									
Operator					See Above					Sex _____									
										25 Safety System _____									
										26 Seat Belt _____									
										27 Safety Status _____									
										28 Airbag _____									
										29 Airbag Status _____									
										30 Speed Code _____									
										31 Year Code _____									
										32 Injury Status _____									
										33 Damage Code _____									
										Medical Facility _____									
Please Select One of the Following: <input type="checkbox"/> Vehicle 2 # Occupants <input type="checkbox"/> Non-Motorist A Type _____										Action _____ Location _____ Condition _____									
License # _____ St _____ DOB/Age _____					Reg # _____ Reg Type _____ Reg State _____					Sex _____ Lic. Class _____ Lic. Restrictions _____ CDL Endorsement _____									
Operator _____					Owner _____					Veh Year _____ Veh Make _____ Veh Config _____									
Address _____					Address _____					City _____ State _____ Zip _____									
City _____ State _____ Zip _____					City _____ State _____ Zip _____					Insurance Company _____									
Vehicle Travel Direction: [N S E W] Responding to Emergency? _____					Event Sequence _____					Most Harmful Event _____									
Citation # (If Issued) _____					Driver Contributing Code _____					Underride/Override _____ Towed _____									
Violation 1: Ch _____ Sec _____ Violation 2: Ch _____ Sec _____					Underride/Override _____ Towed _____														
Violation 3: Ch _____ Sec _____ Violation 4: Ch _____ Sec _____					Underride/Override _____ Towed _____														
Please fill out for operator/non-motorist and all occupants involved										Please fill out for operator/non-motorist and all occupants involved									
Name (Last First Middle) _____					Address _____					DOB/Age _____									
Operator/Non-Motorist					See Above					Sex _____									
										25 Safety System _____									
										26 Seat Belt _____									
										27 Safety Status _____									
										28 Airbag _____									
										29 Airbag Status _____									
										30 Speed Code _____									
										31 Year Code _____									
										32 Injury Status _____									
										33 Damage Code _____									
										Medical Facility _____									



## Commonwealth of Massachusetts Motor Vehicle Crash Report

**1]- Light Conditions**

1	Daylight
2	Dawn
3	Dusk
4	Dark - lighted roadway
5	Dark - roadway not lighted
6	Dark - unknown roadway lighting
97	Other
99	Unknown

**2,3]- Weather Conditions**

1	Clear
2	Cloudy
3	Rain
4	Snow
5	Sleet, Hail, Freezing rain
6	Fog, Smog, Smoke
7	Severe Crosswinds
8	Blowing Sand, Snow
97	Other
99	Unknown

**4]- Traffic Control Device Type**

1	No controls (Skip question 5)
2	Stop Signs
3	Traffic control signal
4	Flashing Traffic control signal
5	Yield signs
6	School zone signs
7	Warning signs
8	Railroad crossing device
99	Unknown

**5]- Traffic Device Functioning Code**

1	Yes
2	No

**6]- Road Surface**

1	Dry
2	Wet
3	Snow
4	Ice
5	Sand, mud, dirt, oil, gravel
6	Water (standing, moving)
7	Slush
97	Other
99	Unknown

**7]- Roadway Intersection Type**

1	Not at intersection
2	Four-way intersection
3	T-intersection
4	Y-intersection
5	On Ramp
6	Off Ramp
7	Traffic circle
8	Five-point or more
9	Driveway
10	Railway grade crossing
99	Unknown

**8]- Trafficway Description**

1	Two-way, not divided
2	Two-way, divided, unprotected median
3	Two-way, divided, positive median barrier
4	One-way, not divided
99	Unknown

**A reportable motor vehicle crash must meet at least one of the following criteria:**

- Occurred on a Public Way
- Property Damage of \$1,000 or greater to any Vehicle/Property
- Non-Fatal Personal Injury
- Resulted in a Fatality

**Filling out the Form**

The following elements must be completed before submitting the form to the RMV:

- Date and Time of the crash
- City/Town where the crash occurred
- Location information of the crash
- License #'s of the operators involved
- Registration #'s of the vehicles involved
- Signature of the Officer

**Truck and Bus Information:**

Please answer the following questions to determine whether or not this section needs to be completed:

- 1) Did this crash involve:
  - A Truck with a gross vehicle weight more than 10,000 lbs or a Hazmat placard?
  - A Bus with seats for more than 8 people including the driver?

**If No, then do not fill out this section.**

- 2) If Yes, then did this crash result in:
  - Person(s) fatally injured?
  - Injured person taken away for medical attention?
  - Any vehicle towed from the scene due to damage?

**If No, then do not fill out this section.**

**If Yes to either 1 or 2, then please complete this section.**

**9]- School Bus Related**

1	Yes
2	No

**10]- Work Zone Related**

1	Yes
2	No

**11]- Manner of Collision**

1	Single Vehicle Crash
2	Rear-end
3	Angle
4	Sideswipe, same direction
5	Sideswipe, opposite direction
6	Head on
7	Rear to Rear
99	Unknown

**12]- First Harmful Event Location**

1	Roadway
2	Median
3	Roadside
4	Shoulder - Paved
5	Shoulder - Unpaved
6	Shoulder - Travel Lane
7	Outside roadway
99	Unknown

**13]- First Harmful Event**

<u>Collision with</u>	
1	Motor vehicle in traffic
2	Parked motor vehicle
3	Pedestrian
4	Cyclist
5	Animal - Deer
6	Animal - Other
7	Moped
8	Workzone maintenance equipment
9	Railway (train, engine)
10	Other movable object
20	Curb
21	Tree
22	Utility Pole
23	Light Pole or other post/support
24	Guardrail
25	Median Barrier
26	Ditch
27	Embankment
28	Bridge
29	Bridge overhead structure
30	Unknown Fixed object
<u>Non-Collision</u>	
40	Overtaken/rollover
41	Jackknife
42	Other non-collision
43	Unknown non-collision
97	Other
99	Unknown

<b>1.4 - Non-Motorist Type</b> 1 Pedestrian 2 Cyclist 3 Skater 4 Train/Trolley Passenger 97 Other 99 Unknown	<b>1.5 - Non-Motorist Action</b> 1 Entering or crossing location 2 Walking, Running or cycling 3 Working 4 Pushing vehicle 5 Approaching or leaving vehicle 6 Working on vehicle 7 Standing 97 Other 99 Unknown	<b>1.6 - Non-Motorist Location</b> 1 Marked crosswalk at intersection 2 At intersection but no crosswalk 3 Non-intersection crosswalk 4 In roadway 5 Not in roadway 6 Median (but not on shoulder) 7 Island 8 Shoulder 9 Sidewalk 10 Shared-use paths or trails 99 Unknown	<b>1.7 - Non-Motorist Condition Code</b> 1 Apparently Normal 2 Physical Impairment 3 Emotional (ex: Depression, angry) 4 Illness 5 PFI asleep, fainted, fatigue, etc. 6 Under the influence of alcohol/drugs/mad 97 Other 99 Unknown	<b>1.8 - License Class</b> A Class A B Class B C Class C D Class D M Class M 99 Unknown	
<b>1.9 - License Restriction Code</b> 1 None 2 [B] Corrective Lenses 3 [C] Mechanical Devices 4 [D] Prosthetic Aid 5 [E] Automatic Transmission 6 [F] Outside Mirror 7 [G] Daylight Only 8 Employment Use Only 9 [I] Limited Use 10 Other 11 [K] CDL - Intricate Only 12 [L] Vehicles w/out air brakes 13 [M] Except Class A & B bus 14 [N] Except Class A & B bus 15 [O] Except Tractor-Trailer 16 Farm Vehicle 99 Unknown	<b>1.10 - Vehicle Configuration Code</b> 1 Passenger car 2 Light truck (Van, mini-van, pick-up, sport utility) 3 Motorcycle 4 Bus (15 or more passengers) 5 Bus (7-15 passengers) 6 Single unit truck (2 axles, 6 tires) 7 Single unit truck (3 or more axles) 8 Truck/trailer 9 Tractor (Bobtail) 10 Tractor/trailer 11 Tractor/doubles 12 Tractor/triples 13 Unknown heavy truck 14 Motor home/recreational 97 Other 99 Unknown	<b>1.11 - Vehicle Action Prior to Crash</b> 1 Traveling Straight ahead 2 Slowing or stopped 3 Turning right 4 Turning left 5 Changing lanes 6 Entering traffic lane 7 Leaving traffic lane 8 Making U-turn 9 Overtaking/Passing 10 Backing 11 Parked 97 Other 99 Unknown	<b>1.12 - Sequence of Events and Most Harmful Codes</b> <b>Collision with:</b> 1 Motor vehicle in traffic 2 Parked motor vehicle 3 Pedestrian 4 Cyclist 5 Animal - Deer 6 Animal - Other 7 Moped 8 Workzone Maintenance Equipment 9 Railway Vehicle (train, engine) 10 Other Movable Object 11 Unknown Movable Object 20 Car 21 Tree 22 Utility Pole 23 Light Pole or other post/support 24 Guardrail 25 Median Barrier 26 Ditch 27 Embankment 28 Highway Traffic Sign Post 29 Overhead Sign Support 30 Fence 31 Mailbox 32 Impact Attenuator/Crash Cushion 33 Bridge 34 Bridge overhead structure 35 Other Fixed Object (Wall, building, tunnel) 36 Unknown Fixed Object <b>Non-Collision</b> 40 Ran off road right (Sequence event only) 41 Ran off road left (Sequence event only) 42 Cross median/centerline (Sequence event only) 43 Overtaken/yellowed 44 Equipment failure (blown tire, brake failure, etc.) (Sequence event only) 45 Fire/explosion 46 Immersion 47 Jackknife 48 Cargo/equipment loss or shift 49 Separation of units (Sequence event only) 50 Downhill runaway (Sequence event only) 51 Other non-collision 52 Unknown non-Collision 97 Other 99 Unknown		
<b>2.4 - Driver Contributing Code</b> 1 No improper driving 2 Exceeded authorized speed limit 3 Disregarded traffic signs, signals, road markings 4 Failed to yield right of way 5 Followed too closely 6 Made an improper turn 7 Driving too fast for conditions 8 Wrong side or wrong way 9 Failure to keep in proper lane or running off road 10 Operating vehicle in erratic, reckless, careless, negligent or aggressive manner 11 Swerving or avoiding due to wind, slippery surface, vehicle, object, non-motorist in roadway, etc. . . 12 Over-concentrating/over-steering 13 Glare 14 Physical Impairment 15 Emotional 16 Illness 17 History Head/Epilepsy/Fainting 18 Visibility Obstructed 19 Inattention 20 Distracted 21 Fatigue/drowsy 22 Operating defective equipment 23 Cellular telephone 24 Fax machine 25 Computer 26 On-board navigation system 27 Two-way radio 97 Other improper action 99 Unknown	<b>2.5 - Underride/Override Code</b> 1 None 2 Underride 3 Override 99 Unknown <b>2.6 - Seating Position</b> 1 Front seat - left seat (or motorcycle driver) 2 Front seat - middle 3 Front seat - right side 4 Second seat - left side (or motorcycle passenger) 5 Second seat - middle 6 Second seat - right side 7 Third row - left side (or motorcycle passenger) 8 Third row - middle 9 Third row - right side 10 Steeper section of cab 11 Enclosed passenger area 12 Unenclosed passenger area 13 Trailing Unit 14 Riding on vehicle exterior 97 Other 99 Unknown <b>2.7 - Safety System Used</b> 0 None used 1 Shoulder and lap belt 2 Lap belt only 3 Shoulder belt only 4 Child safety seat 5 Helmet (motorcycle only) <b>Codes 6-10 Non-Motorist Only</b> 6 Helmet 7 Protective Pads (elbows, knees, etc. . .) 8 Reflective Clothing 9 Lighting 10 Other 99 Unknown	<b>2.8 - Air Bag Status Code</b> 1 Deployed - Front 2 Deployed - Side 3 Deployed - Both Front/Side 4 Not Deployed 5 Not Applicable 99 Unknown <b>2.9 - Air Bag Switch Code</b> 0 Not Applicable 1 Switch in ON position 2 Switch in OFF position 3 ON-OFF switch not present 4 Unknown if switch is present 99 Unknown <b>2.10 - Ejection Code</b> 0 Not ejected 1 Totally ejected 2 Partially ejected 3 Not applicable 97 Other 99 Unknown <b>2.11 - Trapped Code</b> 0 Not trapped 1 Freed by mechanical means 2 Freed by non-mechanical means 99 Unknown <b>2.12 - Injury Status</b> 1 Fatal injury <b>Non-Fatal Injury</b> 2 Incapacitating 3 Non-incapacitating 4 Possible 5 No injury 99 Unknown <b>2.13 - Property Type Code</b> 1 State 2 MDC 3 Municipal 4 Utilities 97 Other 99 Unknown <b>2.14 - Hazardous Placed</b> 1 Yes 2 No 99 Unknown			
<b>3.5 - Carrier Issuing Authority Code</b> 1 US DOT 2 ICC 3 State 99 Unknown	<b>3.6 - Interstate</b> 1 Yes 2 No 99 Unknown	<b>3.7 - Cargo Body Type</b> 0 Not Applicable 1 Box (15 or more) 2 Box (7-15) 3 Van 4 Grain/gravel truck 5 Pole 6 Cargo tank 7 Flatbed 8 Dump 9 Concrete Mixer 10 Auto transporter 11 Garbage truck 97 Other 99 Unknown	<b>3.8 - Gross Weight Code</b> 1 Less than 10,000 lbs 2 10,001 - 26,000 lbs 3 More than 26,000 lbs <b>3.9 - Hazard Material 1 Digit Code</b> 1 Explosives 2 Gases 3 Flammable liquid 4 Flammable solids 5 Oxidizing substances 6 Poisonous substances 7 Radioactive Material 8 Corrosives 9 Misc. Dangerous goods	<b>3.10 - Trailer Length</b> 1 28 feet 2 45 feet 3 48 feet 4 53 feet 97 Other	<b>3.11 - Hazard Material Release Code</b> 1 Yes - materials released 2 No materials released 99 Unknown

### Data Element Definitions:

1 - Light Conditions	The type of light that existed at the time of the crash.
2 - Weather Conditions	The prevailing atmospheric conditions at the time of the crash.
3 - Weather Conditions	The secondary atmospheric conditions at the time of the crash, if applicable.
4 - Traffic Control Device type	The type of traffic control applicable to the crash location.
5 - Traffic Device Functioning	An answer to whether or not the traffic control device was functioning or not.
6 - Road Surface	The roadway surface condition at the time and place of the crash.
7 - Roadway Intersection Type	The type of intersection that the crash occurred at.
8 - Trafficway Description	An indication of whether or not a trafficway is divided and whether it serves one way or two way traffic.
9 - School Bus Related	Indicates if a school bus is involved in the crash.
10 - Work Zone Related	Indicates if the crash occurred in or near a construction, maintenance or utility work zone regardless of whether or not workers were present.
11 - Manner of Collision	The identification in a crash of the manner in which 2 vehicles in transport initially came together.
12 - First Harmful Event Location	The location of the first harmful event as it relates to its position within or outside the trafficway.
13 - First Harmful Event	The injury or damage producing event which characterizes the crash type and identifies the nature of the first harmful event.
14 - Non-Motorist Type	The type of non-motorist.
15 - Non-Motorist Action	The action of the non-motorist prior to the crash.
16 - Non-Motorist Location	The non-motorist's location with respect to the roadway prior to the crash.
17 - Non-Motorist Condition	The condition of the non-motorist immediately prior to the crash.
18 - License Class	The type of commercial or non-commercial vehicle that a licensed driver has been examined on and/or approved to operate.
19 - License Restrictions	Restrictions assigned to an individual's driver license by the license examiner.
20 - Vehicle Configuration	Indicates the general configuration of the vehicle.
21 - Vehicle Action Prior to Crash	What the vehicle was doing prior to the crash.
22 - Sequence of Events	The events in sequence for this vehicle crash.
23 - Most Harmful Event	Event which produced the most severe injury or greatest property damage for this vehicle.
24 - Driver Contributing Code	The actions of the driver which may have contributed to the crash.
25 - Underride/Override	An Underride refers to this vehicle sliding under another vehicle during a crash. An Override refers to this vehicle riding up over another vehicle. Either can occur with a parked vehicle.
26 - Seating Position	Location of occupant in, on, or outside of the motor vehicle prior to the impact of the crash.
27 - Safety System used	The restraint equipment used by the occupant or the safety equipment used by the non-motorist.
28 - Air Bag Status	Deployment status of an air bag relative to the position of the occupant.
29 - Air Bag Switch	The position of the air bag switch.
30 - Ejection Code	The location of each occupants body as being completely or partially thrown from the vehicle as a result of the crash.
31 - Trapped Code	Persons who are mechanically restrained in the vehicle by damaged vehicle components as a result of a crash, and are freed from the vehicle.
32 - Injury Status	The level of injury severity for a person involved in the crash.
33 - Transported by	Identity of unit providing transport to medical facility receiving patient.
34 - Property Type	The type of property that was damaged in the crash.
35 - Carrier Issuing Authority	Organizational entity with the power to license.
36 - Interstate	Indication whether or not this vehicle is being used for commerce, traffic or trade across state lines.
37 - Cargo Body Type	The type of body for buses and trucks over 10,000 pounds GVWR.
38 - Gross Weight	The gross weight that the vehicle can tow or carry. This is used for DOT regulation.
39 - Trailer Length	Length in feet of trailer.
40 - Hazardous Placard	A diamond shaped sign that must be affixed to any motor vehicle that carries hazardous materials.
41 - Hazmat Material 1 Digit	The hazard class of the material being transported.
42 - Hazmat Release	Indication whether hazardous materials were released from the cargo compartment.
Responding to Emergency	Indicates vehicles involved in the crash such as military, police, ambulance, fire, etc., which were on an emergency response with physical emergency signals in use-typically light blinking, siren sounding, etc... Yes only if the vehicle was on an emergency response.
Towed	Refers to whether or not the vehicle was towed from the scene due to damage.
Citation Area	If a citation was issued, please fill in the citation # and the chapter and section of the violations.

# APPENDIC C

## NARRATIVE SEARCH WORKSHEET

Non- Work Zone Narrative	Enter Crash number	Indicates Work Zone Involvement (Y/N)	Indicate the number of times a Search Word is present													Other words or phrases which indicate work zone involvement				
			Arrowboard	Arrow Board	Closed	Closure	Cone	Coned	Cones	Construction	Orange	Road Work	Work	Worker	Work Zone	Zone				
1																				
2																				
3																				
4																				
5																				
6																				
7																				
8																				
9																				
10																				
11																				
12																				
13																				
14																				
15																				

APPENDIX D

CONFLICT AND EVENT WORKSHEET

Name of Observer: \_\_\_\_\_  
Date: \_\_\_\_\_  
Location: \_\_\_\_\_  
Street: \_\_\_\_\_  
Nearest Cross Street: \_\_\_\_\_  
Time of Observation: \_\_\_\_\_ AM/PM to \_\_\_\_\_ AM/PM  
Weather: \_\_\_\_\_  
Speed Limit: \_\_\_\_\_  
Hourly Traffic Volume: \_\_\_\_\_  
Type of  
Construction: \_\_\_\_\_  
% Heavy Vehicles \_\_\_\_\_

Site Description:  
\_\_\_\_\_  
\_\_\_\_\_  
\_\_\_\_\_  
\_\_\_\_\_

Police Officer present: Y            N            Not Sure            How Many: \_\_\_\_\_  
Flagger Present:        Y        N        Not Sure        How Many: \_\_\_\_\_

Number of Vehicles/Motorized Equipment and Description:  
\_\_\_\_\_  
\_\_\_\_\_  
\_\_\_\_\_

Describe any conflicts/events/unusual happenings:

## REFERENCES

1. American Association of State Highway and Transportation Officials. AASHTO's Recommendations for the Interstate System of the Future. *Transportation Invest in Our Future*, February 2007. [http://www.transportation1.org/tif1report/highway\\_01.html](http://www.transportation1.org/tif1report/highway_01.html). Accessed April 2, 2011.
2. Keenan, C. Work Zones That Work. *Public Roads*, Vol. 68, No. 3, Nov./Dec. 2004, pp. 22-29.
3. Report Card for America's Infrastructure. American Society of Civil Engineers. <http://www.infrastructurereportcard.org/fact-sheet/roads>. Accessed August 23, 2011.
4. Federal Highway Administration. Work Zone Safety and Mobility Fact Sheet. *FHWA Safety*, 2009. [http://safety.fhwa.dot.gov/wz/wz\\_awareness/2009/factsht09.cfm](http://safety.fhwa.dot.gov/wz/wz_awareness/2009/factsht09.cfm). Accessed April 2, 2011.
5. FHWA Work Zone Mobility and Safety Product Team. Work Zone Best Practices Guidebook. Federal Highway Administration, FHWA-OP-00-010, April 2000.
6. Federal Highway Administration (FHWA). *Manual on Uniform Traffic Control Devices*. 2009 Edition, Federal Highway Administration, 2009.
7. Sankar, P., K. Jeannotte, J. P. Arch, M. Romero, and J. E. Bryden. Work Zone Impacts Assessment: An Approach to Assess and Manage Work Zone Safety and Mobility Impacts of Road Projects. Federal Highway Administration, Washington, D.C., FHWA-HOP-05-068, May. 2006.
8. Federal Highway Administration. National Highway Work Zone Safety Program. *FHWA Safety*, [http://safety.fhwa.dot.gov/wz/wz\\_natl\\_pro.cfm#one](http://safety.fhwa.dot.gov/wz/wz_natl_pro.cfm#one). Accessed February 25, 2011.
9. Mahoney, K. M., Porter, R. J., Taylor, D. R., Kulakowski, B.T., and G. L. Ullman. National Cooperative Highway Research Program. *Design of Construction Work Zones on High-Speed Highways*. NCHRP Report 581. 978-0-309-09879-3. 2007
10. Antonuci, N. D., K. K. Hardy, J. E. Bryden, T. R. Neuman, R. Pfefer, and K. Slack. *A Guide for Reducing Work Zone Collisions*. NCHRP 50-17. 0077-5614. 2005.
11. MassHighway Work Zone Safety Guidelines for Massachusetts Municipalities and Contractors. MassDOT, 2011. [http://www.massdot.state.ma.us/highway/downloads/flaggers/flip\\_book.pdf](http://www.massdot.state.ma.us/highway/downloads/flaggers/flip_book.pdf). Accessed May 4, 2011.
12. Wang, J., W. E. Hughes, F. M. Council, and J. F. Paniati. Investigation of Highway Work Zone Crashes: What We Know and What We Don't Know. In *Transportation Research Record: Journal of Transportation Research Board*, No. 1529. Transportation Research Board of the National Academies, Washington, D.C., 1996, pp. 54-62.
13. Turner, D. J. What's a Work Zone? *Public Roads*, Vol. 62, No. 6, May/Jun. 1999.

14. American National Standard. Manual On Classification of Motor Vehicle Traffic Accidents. American National Standards Institute, Itasca, National Standard ANSI D16.1-2007, 2007.
15. Akepati, S. R., and S. Dissanayake. Characteristics and Contributory Factors of Work Zone Crashes. Presented at 90th Annual Meeting of the Transportation Research Board, Washington, D.C., 2011.
16. Garber, N. J., and M. Zhao. Distribution and Characteristics of Crashes at Different Work Zone Locations in Virginia. In Transportation Research Record: Journal of Transportation Research Board, No. 1794. Transportation Research Board of the National Academies, Washington, D.C., 2002, pp. 19-25.
17. National Work Zone Safety Information Clearinghouse. Large Truck Related Work Zone Crashes. workzonesafety.org, March 26, 2010. [http://www.workzonesafety.org/crash\\_data/workzone\\_fatalities/large\\_truck\\_crashes](http://www.workzonesafety.org/crash_data/workzone_fatalities/large_truck_crashes). Accessed February 25, 2011.
18. UMass Safe. An Examination of Massachusetts Crashes Involving Commercial Motor Vehicles Occuring in Work Zones. University of Massachusetts, Amherst.
19. Li, Y., and Y. Bai. Highway Work Zone Risk Factors and Their Impact on Crash Severity. *Journal of Transportation Engineering*, Vol. 135, No. 10, Oct. 2009, pp. 694-701.
20. Sulbaran, T., and D. Marchman. Effectiveness of Increased Law Enforcement Surveillance. Mississippi Department of Transportation, Final Report 978-1-60402-843-0, July 2007.
21. Kamyab, A., T. McDonald, B. Storm, and M. Anderson-Wilk. Effectiveness of Extra Enforcement In Construction and Maintenance Work Zones. Center for Transportation Research and Education, Ames, Final Report MwSWZDI Year 4 Technology, May 2003.
22. Vernon, D.D., E. M. Diller, L. J. Cook, J.C. Reading, A. J. Suruda, J. M. Dean. Evaluating the crash and citation rates of Utah drivers licensed with medical conditions, 1992–1996. *Accident Analysis and Prevention*. Vol. 34, No. 2, 2002, pp. 237-246.
23. Dulisse, B. Driver Age and Traffic Citations Resulting From Motor Vehicle Collisions. *Accident Analysis and Prevention*. Vol. 29, No. 6, 1997, pp. 779-783.
24. Ullman, G. L., M. D. Finley, and L. Theiss. Categorization of Work Zone Intrusion Crashes. Presented at 90th Annual Meeting of the Transportation Research Board, Washington, D.C., 2011.
25. Heaslip, K., J. Collura, and M. Knodler. Evaluation of Work Zone Design Features to Aid Older Drivers. *ITE Journal*, Vol. 81, No. 3, March 2011, pp. 36-40.
26. Finley, M. D. Field Evaluation of Motorists' Reaction to Reduced Work Zone Speed Limits and Other Work Zone Conditions Presented at 90th Annual Meeting of the Transportation Research Board, Washington, D.C., 2011.

27. McAvoy, D. S., S. Duffy, and H. S. Whiting II. A Simulator Study of Precipitating Factors for Work Zone Crashes. Presented at 90th Annual Meeting of the Transportation Research Board, Washington, D.C., 2011.
28. Parker, M. R., and C. V. Zeeger. Traffic Conflict Techniques for Safety and Operations Observers Manual. Federal Highway Administration U.S. Department of Transportation, McLean, Observers Manual FHWA-IP-88-027, January 1989.
29. Tiwari, G., D. Mohan, and J. Fazio. Conflict Analysis for Prediction of Fatal Crash Locations in Mixed Traffic Streams. *Accident Analysis and Prevention*. Vol. 30, No. 2, 1998, pp. 207-215.
30. Ge, X., J. Lu, Q. Xiang, and P. Wang. Study on Driving Behavior and Traffic Conflict at Highway Intersection. *Workshop on Power Electronics and Intelligent Transportation System*, 2008. pp. 492-495.
31. Federal Motor Carrier Safety Administration. Privacy Impact Assessment SAFETYNET. US DOT, December 5, 2003. [http://www.dot.gov/pia/fmcsa\\_safetynet.htm](http://www.dot.gov/pia/fmcsa_safetynet.htm). Accessed March 18, 2011.
32. The Johns Hopkins University Applied Physical Laboratory. What Already Exists? CVISN Guide to Safety Information Exchange, Vol. Baseline 1.0, February 2002, pp. 3-1 - 3-22.
33. Office of Degree Requirements. Guidelines for Master's Thesis and Doctoral Dissertations. Graduate School. University of Massachusetts Amherst. March 2010.