



University of
Massachusetts
Amherst

Multi Rotor Wind Turbine Design And Cost Scaling

Item Type	Thesis (Open Access)
Authors	Verma, Preeti
DOI	10.7275/4460782
Download date	2026-05-17 21:28:34
Link to Item	https://hdl.handle.net/20.500.14394/44599

MULTI ROTOR WIND TURBINE DESIGN AND COST SCALING

A Thesis Presented

by

PREETI VERMA

Submitted to the Graduate School of the
University of Massachusetts Amherst in partial fulfillment
of the requirements for the degree of

MASTER OF SCIENCE IN MECHANICAL ENGINEERING

September 2013

Mechanical and Industrial Engineering

MULTI ROTOR WIND TURBINE DESIGN AND COST SCALING

A Thesis Presented

by

PREETI VERMA

Approved as to style and content by:

James F. Manwell, Co-chair

Jon G. McGowan, Co-chair

Sergio F. Brena, Member

Donald L. Fisher, Department Chair
Mechanical and Industrial Engineering

*To my supportive and loving parents, Rani Verma & R. S. Verma,
and my sister, Gargi Verma.*

ACKNOWLEDGMENTS

I thank my advisor, Prof. James F. Manwell for the several fruitful discussions regarding the underlying requirements of my work. Thank you for helping me understand the subtle aspects of up-wind turbine design.

Thanks to Prof. Jon G. McGowan for his guidance and support.

Thanks to Prof. Sergio F. Brena for his support and insightful feedback on Structural Design.

Thanks to my loving parents for their continued love and support during the writing of this thesis.

ABSTRACT

MULTI ROTOR WIND TURBINE DESIGN AND COST SCALING

SEPTEMBER 2013

PREETI VERMA

M.S.M.E., UNIVERSITY OF MASSACHUSETTS AMHERST

Directed by: Professor James F. Manwell and Professor Jon G. McGowan

The current generation wind turbines are upscaled into multi megawatt range in terms of output power. However, the energy benefit from the turbine is offset by the increased mass and cost. Twenty MW wind turbines are now feasible with rotor diameters up to 200 m, according to a new report from the EU-funded UpWind project in 2011. The question is, how much bigger can wind turbines get realistically? One concept worth considering, and the one that is the subject of this thesis, is to have more than one rotor on a single support structure. Such turbines could have a greater power to weight ratio. Multi-rotor systems also offer the advantage of standardization, transportation and ease of installation and maintenance.

In this thesis the NREL 5 MW single rotor baseline wind turbine is compared with a 5 MW multi-rotor wind turbine. The multiple rotors are downscaled using scaling curves keeping the 5 MW baseline machine as reference.

TABLE OF CONTENTS

	Page
ACKNOWLEDGMENTS	iv
ABSTRACT	v
LIST OF TABLES	viii
LIST OF FIGURES	ix
 CHAPTER	
1. INTRODUCTION TO WIND TURBINES	1
1.1 Wind Power Around the World	1
1.2 Basics of Wind Turbines	3
1.2.1 Power Curve	3
1.2.2 One-Dimensional Momentum Theory and Betz Limit	5
1.2.3 Parametric Sensitivity	6
2. INTRODUCTION TO MULTI ROTOR WIND TURBINES	7
2.1 Merits and Drawbacks of MRWTs	9
2.2 Motivation	10
2.3 Overview of Key Historical Precedents	10
2.3.1 Early MRWT Designs	11
2.3.2 Recognition of Standardization Benefit	12
2.3.3 Modern MRWTs	13
2.3.4 Scaling Relationships	13
3. SCALING ECONOMICS	16
3.1 Scaling Trends	16
3.1.1 Geomteric Scaling	16

3.1.2	Dynamic Scaling	17
3.1.3	Empirical Scaling	17
3.2	Scaling Effects on Wind Turbine Design	19
3.3	Aerodynamic Interaction	21
3.4	Other Scaling Facts	22
3.5	5 MW Three-Rotor Wind Turbine RNA Components	23
3.5.1	Properties of Down-Scaled RNA	23
3.5.2	RNA Cost and Weight Scaling	24
4.	SUPPORT STRUCTURE DESIGN	31
4.1	Design Requirement	32
4.2	Design Specifications	32
4.2.1	Material	32
4.2.2	Design conditions	32
4.2.3	Design Loads	33
4.3	Structural Scheme	35
4.4	Final Design	39
4.4.1	Analysis	40
4.4.2	Blade Deflection	44
4.5	Weight Summary and Comparison	46
5.	CONCLUSION	50
	BIBLIOGRAPHY	52

LIST OF TABLES

Table	Page
3.1 Properties of NREL 5 MW baseline turbine	24
3.2 Properties of downscaled 1.67 MW rotor for MRWT	24
3.3 3RWT RNA components' scaled costs and weights using the baseline curve	29
3.4 Revised 3RWT RNA components using WindPACT scaling curve nacelle mass	30
4.1 Design data for a single rotor of the multi-rotor system	33
4.2 Power Scaling of Rotor Configurations with Shear Exponent	37
4.3 MRWT Weight Summary	46
4.4 MRWT Cost Summary	47

LIST OF FIGURES

Figure	Page
1.1 World cumulative installed wind power capacity, 1980 - 2009 [7].....	2
1.2 Cumulative installed wind turbine capacity : top ten countries, 2010 [4]	2
1.3 Major components of a HAWT [22]	4
1.4 Typical wind turbine power curve [22]	4
2.1 Increasing wind turbine rotor size [10]	8
2.2 2-Rotor Danish wind mills, 1873 [25]	11
2.3 3-Rotor turbine concept by Hermann Honnef, 1930 [9]	12
2.4 Percy Thomas' two rotor aerogenerator tower wind turbine patent design [31]	13
2.5 Concept wind station with thirty-four 100 kW wind generators at seven levels, 1976 [14]	14
2.6 A Lagerwey 4 rotor system [9]	15
3.1 NREL study tower mass scaling [11]	18
3.2 Scaling of wind turbine nacelle system mass [3]	22
3.3 Wind turbine nacelle system mass above 80m diameter [3]	23
3.4 NREL study blade mass scaling [11].....	26
4.1 NREL baseline machine response curves [18]	34
4.2 Three-Rotor Turbine Configurations.....	36

4.3	Three arm support structure configuration	38
4.4	Three arm truss type support frame	39
4.5	Triangular truss type support frame	41
4.6	Triangular truss type support frame dimensions	42
4.7	Triangular truss frame member assignments	43
4.8	SAP2000: Frame members for tower and space frame, shell elements for bearings	44
4.9	Truss type support frame deflections	45
4.10	Design capacity check	46
4.11	Maximum stress in frame member	47
4.12	First natural frequency, side to side mode	48
4.13	Second natural frequency, fore and aft mode	49
4.14	Third natural frequency, twisting mode	49

CHAPTER 1

INTRODUCTION TO WIND TURBINES

The increasing awareness of the need for environmentally sustainable energy production has driven the promotion of wind energy conversion systems. Wind is a form of solar power, created by the uneven heating of the Earth's surface. Wind turbines have been developed for over a millenium and are available in various configurations of horizontal and vertical axis. Wind energy conversion systems tranform kinetic energy available in the wind into eletrical energy. Due to some favourable characteristics such as economical viability, a clean energy resource, low environmental impact, and the potential to cover a large percentage of the energy requirement, this technology has grown considerably in the last few decades. Presently, wind energy accounts for 2.3% of the total U.S. electricity supply. The cost to produce a unit of electricity from the wind has decreased by 80% during the last twenty years [6].

The United Nations has said if greenhouse gas emissions are not cut by 70% within the next 30 years, the world will face detrimental climate system consequences. This necessitates continued research and development in clean energy technologies in order to create more environmentally friendly energy solutions.

1.1 Wind Power Around the World

Figure 1.1 shows the cumulative installed wind capacity in the world up to 2009 which soared above 150,000 MW, while Figure 1.2 shows that, just the top ten participating countries' wind turbine installed capacity exceeds that of 2009, in 2010.

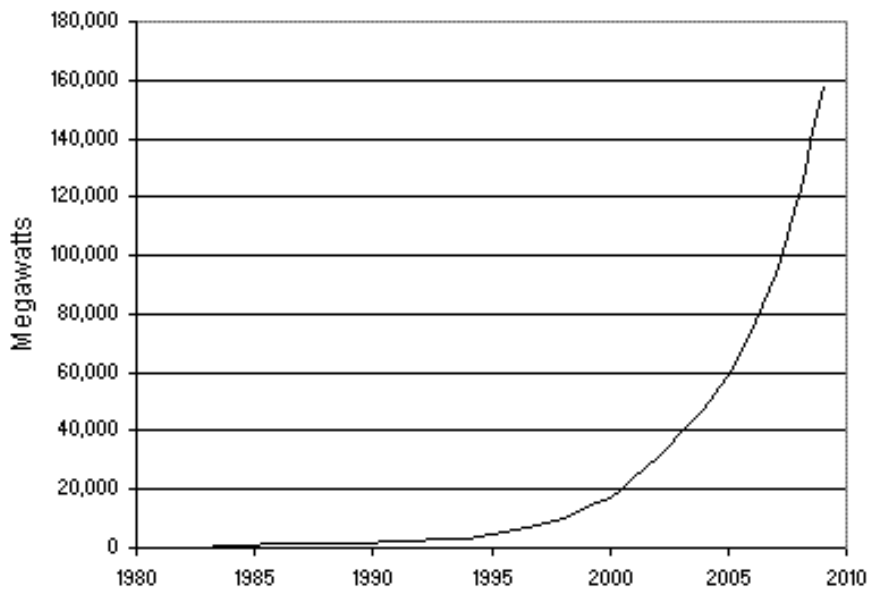

Figure 1.1. World cumulative installed wind power capacity, 1980 - 2009 [7]

China led the way in 2009 with an astonishing 13,000 MW of new wind capacity, the first time any country built more than 10,000 MW in a single year.

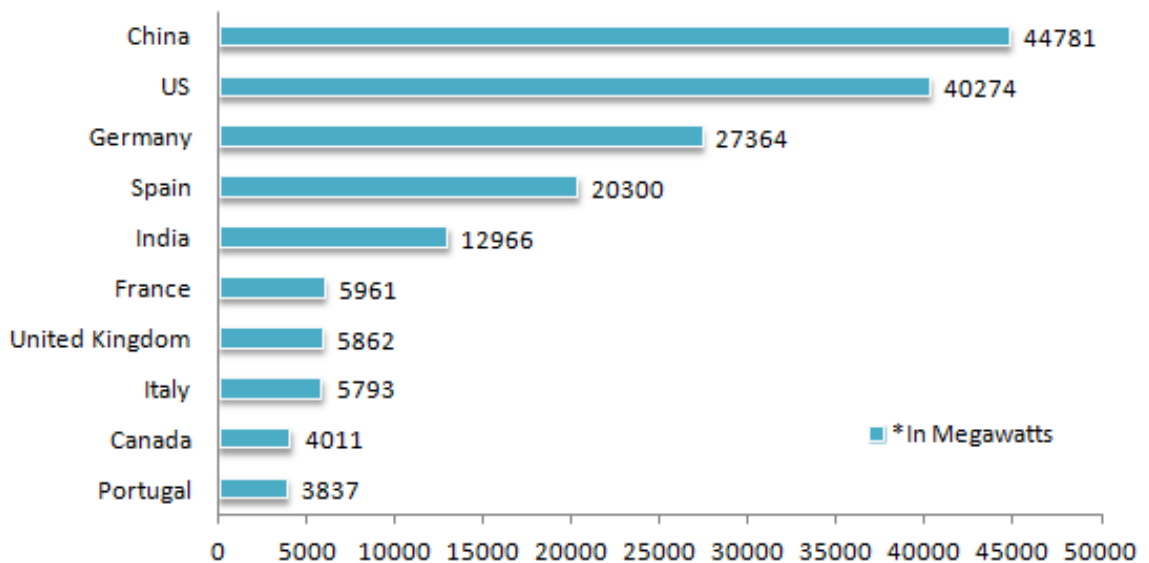

Figure 1.2. Cumulative installed wind turbine capacity : top ten countries, 2010 [4]

The potential for wind power has been estimated to be 600 EJ/yr (167,000 TWh) [29]. Wind power is growing at the rate of 30% annually, with a worldwide installed capacity of 198 gigawatts (GW) in 2010 [20], and is widely used in Europe, Asia, and the United States.

1.2 Basics of Wind Turbines

Most modern horizontal axis wind turbines (HAWT) have the following principle subsystems as shown in Figure 1.3: i) the rotor-nacelle assembly (RNA), ii) the support structure which includes the tower and the foundation, and iii) the electrical system including cables, transformers, switchgear etc. The RNA is mounted on the tower and has four main components: i) a rotor with two or three blades with a supporting hub to extract the flow energy from moving air and convert it into rotational energy in the shaft, ii) a transmission system to gear up the rotational speed of the shaft, usually consisting of shafts, gearbox, coupling, and a mechanical brake, iii) a generator to convert the mechanical energy into electrical energy, and iv) a controller to supervise the performance of the system.

1.2.1 Power Curve

The power output of a wind turbine varies with wind speed and every wind turbine has a characteristic power performance curve. With the curve it is possible to predict the energy production of a wind turbine without considering the technical details of its various components. The power curve gives the electrical power output as a function of the hub height wind speed. Figure 1.4 shows an example of a power curve for a hypothetical wind turbine.

The performance of a given wind turbine relates to three key points on the velocity scale: i) cut-in speed which is the minimum wind speed at which the machine will deliver useful power, ii) rated wind speed at which the rated power is reached, and iii)

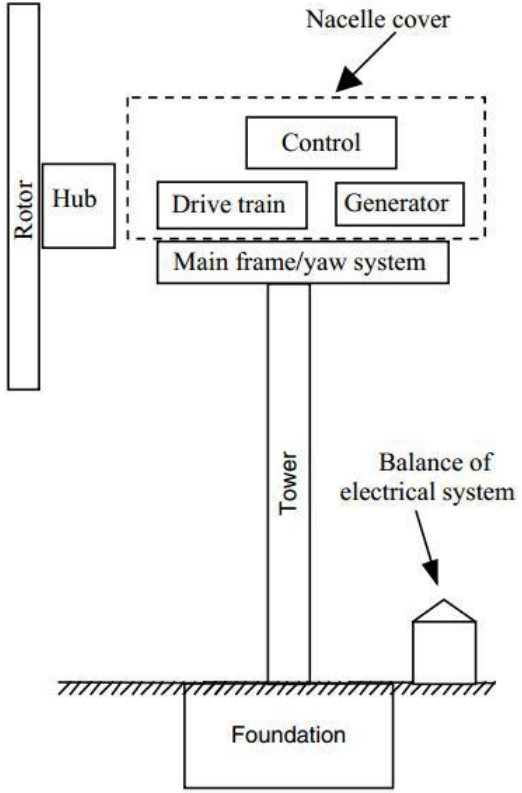

Figure 1.3. Major components of a HAWT [22]

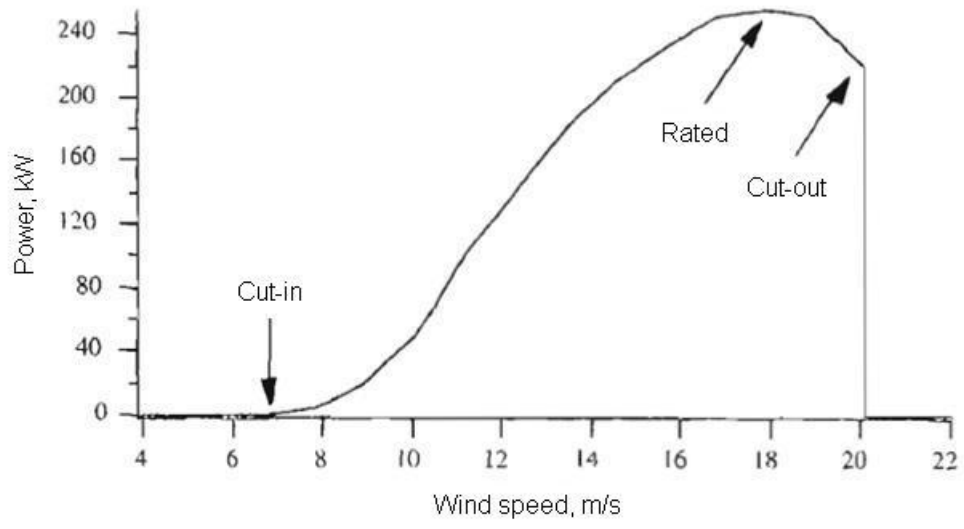

Figure 1.4. Typical wind turbine power curve [22]

the cut-out speed which is the maximum wind speed at which the turbine is allowed to deliver power, limited by engineering design and safety constraints.

Power curves for existing machines can normally be obtained from the manufacturer, derived from field tests using standardized testing methods. The process of determination of power characteristics of the wind turbine components and their efficiencies is very complex.

1.2.2 One-Dimensional Momentum Theory and Betz Limit

From momentum theory, it can be shown that the power of a cylinder of air of radius R and density ρ moving with a given speed v can be expressed as:

$$P_w = \frac{1}{2}\rho\pi R^2 v^3 \quad (1.1)$$

Since the air has to flow away from the wind turbine to be in a steady-state condition, the air stream cannot be stopped by the rotor. Thus, only a fraction of the kinetic energy available in the wind can be extracted. This fraction is referred to as the power coefficient, C_p of the wind turbine. The maximum value of C_p that can be achieved is $\frac{16}{27}$ or 59.26% and this is called the *Betz Limit*. Therefore, the mechanical power extracted by a wind turbine of radius R from an air stream of speed v is given by:

$$P_{mech} = C_p \frac{1}{2}\rho\pi R^2 v^3 \quad (1.2)$$

The Betz limit is the ideal theoretical C_p and in reality there is a decrease in the maximum achievable power due to: i) rotation of wake behind the rotor, ii) finite number of blades and tip losses, and iii) non-negligible aerodynamic drag on the rotor. The overall turbine efficiency is a function of both the C_p and the mechanical/electrical efficiency of the wind turbine [22]. Equation 1.3 shows the effective

output power of a wind turbine, where η_o is the overall mechanical efficiency of the drive train.

$$P_o = \eta_o C_p \frac{1}{2} \rho \pi R^2 v^3 \quad (1.3)$$

1.2.3 Parametric Sensitivity

It can be seen from Equation 1.3 that the extractable power from the wind turbine varies as the square of the rotor radius R and as the cube of the wind velocity v . Thus the output of a wind turbine greatly depends on the choice of site (mean wind speed) and the size of turbine (rotor radius). Because the potential energy produced from the wind is directly proportional to the cube of the wind speed, increased wind speeds of only a few meters per second can produce a significantly larger amount of electricity.

It should be noted that the C_p is not constant, so in reality most power curves are not purely cubic. In fact, real power curves are closer to linear in the range between cut-in and rated wind speed. The above case holds good for a given C_p at a given wind speed and rotor radius.

CHAPTER 2

INTRODUCTION TO MULTI ROTOR WIND TURBINES

There has been an ever increasing growth in the size of wind turbines over the past decade. Much progress has been seen in land-based wind turbines which have significantly improved and stabilized at 3 MW power capacity [3]. In the past three or four years, interest remains in yet larger turbines for land-based and mainly offshore market.

The current generation of wind turbines have been upscaled into multi megawatt range in terms of output power. However, the energy benefit from these large turbines is offset by the increased mass and cost. In order to find the best locations to harvest wind, it is a natural step to take wind turbines offshore, recognizing onshore environmental impacts and the abundance of better quality wind resources at sea. For offshore wind turbines, support structures are the main cost drivers (over 40% of the system components cost) and it is vital to extract the maximum effect of the wind [23]. In order to do this either the rotors need to be made larger, or more than one rotor must be used. Is up-scaling economically viable?

Twenty MW wind turbines are now possible to manufacture with rotor diameters around 200 m, according to a new report from the EU-funded UpWind project in 2011. This conclusion was not arrived at by simply geometrically up-scaling a 5 MW machine. The design was highly modified: the blades are based on a lighter, better design, with unique adaptations to the design of the controls and sensors. Whether such a large wind turbine is economically feasible remains to be seen. Figure 2.1 illustrates the growth in wind turbine size since 1985. The question is, how much

bigger can wind turbines get realistically? Underlying all research activities is a focus on reducing the Cost of Energy (CoE). The CoE is defined as the unit cost of energy (in \$/KWh) from the wind energy system as shown in Equation 2.1 [22]. Manufacturing single blades exceeding 120 m with current technology, offshore erection with current installation vessels and cranes at this scale, transport limitations etc., indicate that single rotor design seems to be uneconomic at very large scale [24].

$$COE = (\text{Total annualized costs}) / (\text{Annual energy production}) \quad (2.1)$$

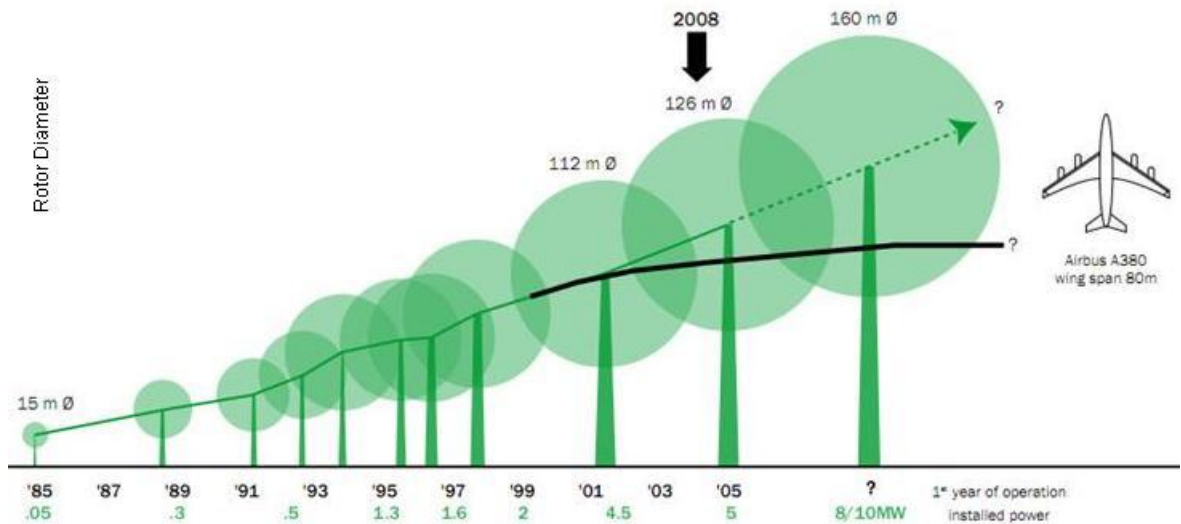

Figure 2.1. Increasing wind turbine rotor size [10]

For this project, it is to be investigated which of the two ideas is better, up-scaling, or multi-rotor arrays. As will be discussed, multi-rotor systems appear to be a feasible option. Scaling principles and empirical relations support this idea and will be discussed in Chapter 3.

The concept of multi-rotor wind turbine (MRWT) systems has been around for about a century now. A MRWT has several wind turbine rotors mounted on a single support structure. In comparison, conventional modern wind turbines have one

rotor. The initial motivation for making multi rotors was in the difficulty of making very large blades due to technology limitations. This was overcome by modern glass composites and the multi-rotor idea has until recently been neglected.

2.1 Merits and Drawbacks of MRWTs

In so far as multi-rotor wind turbines are so different from conventional wind turbines, it is worth summarizing what some of their anticipated advantages (merits) and disadvantages (drawbacks) are.

Merits:

- Reduced blade mass and cost since blade weight increases with diameter faster than power (discussed in Chapter 3).
- Reduced total rotor-nacelle assembly (RNA) weight, possibly result in reduced tower weight and cost. Reduced RNA weight means reduced weight of the transmission-generator assembly as well as that of all the rotors.
- Greater average power due to the possibility to run the rotors at different (variable) speeds. Possibly increased average power output due to interaction of wake vortices of closely spaced turbines (discussed in Chapter 3).
- Ease of installation of smaller rotors.
- Ease of repair and maintenance of smaller components.
- Ease of transport of smaller blades. Smaller components are cheaper and easier to transport and assemble.
- $\frac{1}{n}$ th turbine malfunction upon part failure for n rotor system. Realistically, this is feasible only if a turbine could be allowed to run with only some of its rotors operating (unbalanced forces would need to be considered).

Drawbacks:

- Increased mass of steel in tower top due to support frame to hold and yaw the multiple rotor assembly.
- Increased complexity of system overall.
- Dynamics of tower top structure. Knowledge of effects of rotor interaction and wind shear is essential (discussed in chapter 3).

2.2 Motivation

The purpose of this thesis is to investigate whether there is any reason to think that a land-based MRWT would be preferable to a single rotor wind turbine with the same swept area. The project focusses on a first level analysis. Specifically, the relative weights and costs of two turbines of the same swept area, one with a single rotor, the other with 3 rotors, are considered. Every effort is made to insure that this is an "apples to apples" comparison. That is, the same tip speed ratio and same number of blades are used on each rotor, the same type of tower, the same wind speeds, and the same wind shear etc. are used. To do this, a scaling model is chosen. The design stresses are not used as design driver, but the stresses are accounted for. This will be discussed in detail in Chapter 3. The work is divided into two parts, the first pertains to scaling studies adopted to determine the economic feasibility of the design, and the second discusses the design of the structure to determine its structural feasibility.

2.3 Overview of Key Historical Precedents

This section explains the history of MRWTs keeping in mind the design concept developments. There have been several multi-rotor concepts over the past decade, employing vertical axis, uniaxial etc., machines. However, these concepts do not

contribute much to the key concepts of wind turbine scaling, and horizontal-axis single-plane multi-rotor systems and therefore will not be discussed.

2.3.1 Early MRWT Designs

1. Earliest Record: Wind power was being used by many containment and drying projects in late 1800-century in Denmark. Pumps were initially operated with steam engines. In 1873, the steam was replaced with 3 Dutch mills, two of them being twin-mills as shown in shown in Figure 2.2. The twin mills had 6-winged flap sailing rotors mounted atop mill houses.



Figure 2.2. 2-Rotor Danish wind mills, 1873 [25]

2. Limitation on Wind Turbine Size: The conceptual solution to a large unit capacity when rotor size was limited by steel as the only blade material considered practicable [16]. The multi-rotor concepts were proposed by Hermann Honnef (Germany, 1930s). Figure 2.3 shows a system by Honnef.
3. Smart Design Proposition: The Aerogenerator Tower, with two rotors, was proposed by Percy H. Thomas (US, 1950s) as a smart design to improve efficiency and costs involved in turbine tower construction and erection. The 475-foot tower for supporting a wind turbine of 7,500 kW output, used mounted elements hinged together that were used to not only erect the structure, but as

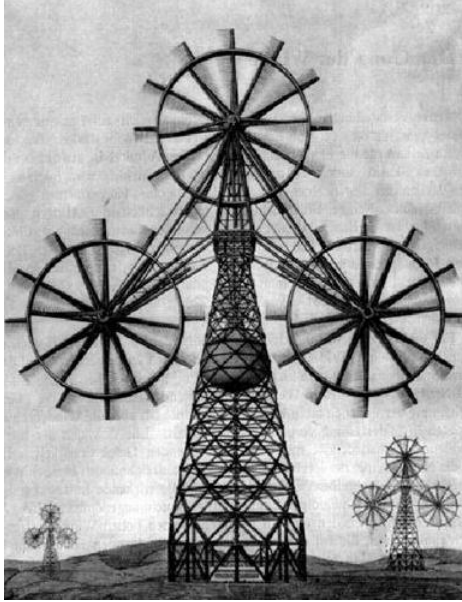

Figure 2.3. 3-Rotor turbine concept by Hermann Honnef, 1930 [9]

a means to assist the erection too. Figure 2.4 shows the United States design patent from 1945. The tower being tall, two rotors were installed to tap into more wind.

2.3.2 Recognition of Standardization Benefit

Capt. William E. Heronemus, is a major inspirational figure in US wind energy, respected teacher, advocate of renewable energy, proponent of advanced visionary concepts for multi rotor systems offshore, and founder of the first university wind energy program in the United States, at the University of Massachusetts. In the 1970s, Heronemus advanced many visionary concepts for multi rotor systems including offshore multi-rotor arrays for hydrogen production [30].

Heronemus contributed the recognition of the potential of multi rotor systems for large unit capacity, the benefit of standardization avoiding upscaling of turbine units and proposed a variety of configurations. Figure 2.5 shows one of his concepts, a thirty-four rotor array wind turbine [8].

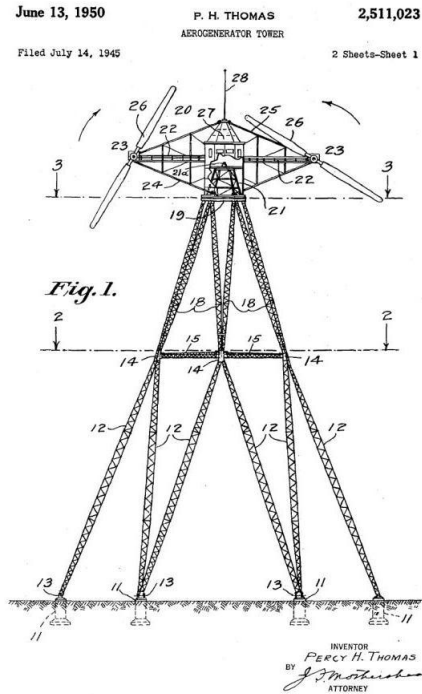

Figure 2.4. Percy Thomas' two rotor aerogenerator tower wind turbine patent design [31]

2.3.3 Modern MRWTs

Henk Lagerweij of Lagerweij Wind has built several MRWTs and has extensive knowledge of key engineering issues such as yawing and rotor interaction. Figure 2.6 shows a Lagerweij multi rotor system. It employed a tree like structure, which is potentially subject to vibrational problems [11], especially if extended to a large array, and hence was not very strength-to-weight efficient.

2.3.4 Scaling Relationships

Peter Jamieson, in 1995, recognized the *scaling principles* (this will be discussed in Chapter 3), implying a fundamental weight advantage of multi rotor systems and developed a case based on commercial data to justify the potential benefit. He put forward his ideas on scaling principles in his book *Innovation in Wind Turbine Design*, in 2011 [16].

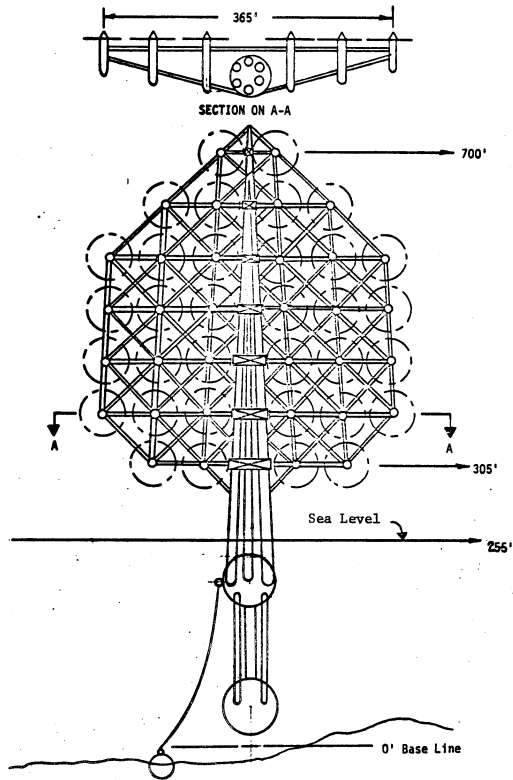

Figure II.2 Wind Station with Thirty-Four 100-Kilowatt Wind Generators at Seven Levels

Figure 2.5. Concept wind station with thirty-four 100 kW wind generators at seven levels, 1976 [14]



Figure 2.6. A Lagerwey 4 rotor system [9]

CHAPTER 3

SCALING ECONOMICS

There have been several attempts to develop modern scaling models for HAWTs. But because wind turbines have changed in size and configuration so rapidly, many models are out of date before they can be used effectively by designers. In the mid to late 1990s, the configuration for utility-scale turbines began to stabilize around the three-bladed, upwind design [3]. This chapter describes scaling of wind turbines in the multi megawatt range and MRWT design concepts with respect to HAWTs.

3.1 Scaling Trends

3.1.1 Geometric Scaling

The simplest scaling procedure is to simply multiply the dimensions of an object uniformly by a similar factor. This method is called geometric scaling which is referred to as the *0th order* of scaling.

The area of any 3D object scales as the square of the length, whereas the volume scales as the cube of the length. Thus, upscaling rotor size by a small fraction (geometric scaling) significantly increases the rotor mass and cost. This relationship, known as the *area-volume relationship* has been adopted by Jamieson to show that having multiple small rotors, each generating a fraction of the total power proves to be more mass effective than a single large rotor of the same power capacity [15]. The mass advantage is observed in the rotor and drive train components.

The above concept is expressed mathematically as

$$K = n \left(\frac{d}{D} \right)^3 = \frac{nm}{M} = \frac{1}{\sqrt{n}} \quad (3.1)$$

where n is the number of rotors of the MRWT and m is the associated mass and d is the diameter of each rotor of the MRWT, M is the mass and D is the diameter of the single large rotor, and K is the ratio of masses of the two systems [15]. The $\frac{1}{\sqrt{n}}$ formula clearly describes the mass advantage (which could mean a cost benefit) of downscaling. In other words, if the rotor diameter is halved, the area (and hence the amount of wind captured) is quartered. However, the mass has decreased to an eighth. Simply put, the mass decreases faster than power with decreasing diameter.

3.1.2 Dynamic Scaling

In a scaling scenario, physical quantities such as load, size, weight etc. vary with the scale factor. In dynamic scaling, let *pre-numbers* be defined as relations between these physical quantities such that the pre-numbers do not vary with the scale factor. For example, limiting stress is one such pre-number in strength-to-weight problems. Thus stress can be used as the design driver, which allows modifying dimensions and offers flexibility relative to the geometric scaling method as it depends on material properties. This method is referred to as the *1st order* of scaling. This method of scaling was not used for the project. However, the stresses are accounted for and will be discussed next.

3.1.3 Empirical Scaling

The *2nd order* of scaling is based on scaling models developed from published wind turbine design and cost data. Scaling curves obtained from plotting the various wind turbine components' weight/cost for a range of rotor size give us mathematical models of design augmentation with size. This scaling method is preferred simply be-

cause, not only does it accommodate geometric and dynamic scaling as compared with published price data, but it is based on successful designs, and includes technological advancements with increasing rotor size over time.

The U.S. Department of Energy's (DoE's) Wind Partnership for Advanced Component Technologies (WindPACT) projects are studies undertaken to identify technology improvements in wind turbines to enable decrease in the CoE [13] [21]. The projects examined a number of conceptual designs of turbines to determine the impact of increasing machine size on total CoE based on published data. NREL's National Wind Technology Center (NWTC) developed a spreadsheet model based primarily on the WindPACT rotor study of scaling relationships to project turbine costs. Figure 3.1 shows the tower mass scaling relationships from the WindPACT study. This thesis mainly uses the NREL scaling model for the MRWT component design.

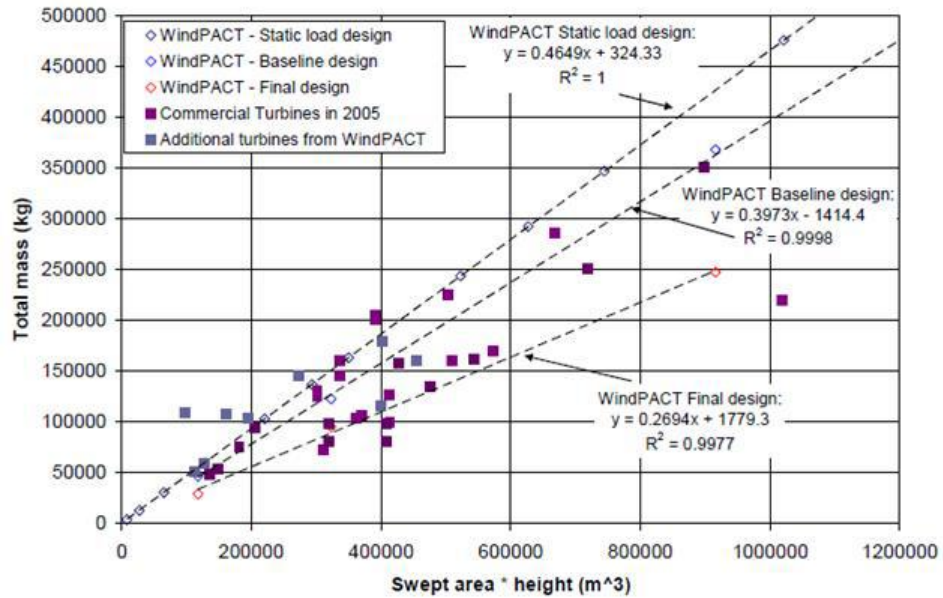

Figure 3.1. NREL study tower mass scaling [11]

3.2 Scaling Effects on Wind Turbine Design

Empirical models provide component weights and costs. Using such models to downscale for the purpose of MRWTs calls for certain design considerations that are not included in the scaling laws. The scaling effects to be considered are:

1. Tip Speed: In upscaling a wind turbine, a consistent basis of comparison requires that a representative tip speed is constant. This preserves the flow geometry in terms of the relationship between rotor speed and wind speed at any given operating point. Maintaining a given tip speed at any given wind speed implies that in up-scaling, rotor angular velocity, ω , must vary inversely with diameter, D , and decrease with increasing turbine size [16]. For this project, the MRWT rotors are designed for same tip speed as the single large rotor.
2. Self Weight Loads Scaling: The blade bending load due to self weight will be proportional to the product of the mass scaling as D^3 and a moment arm scaled as D . Hence blade bending moments will scale as D^4 . Thus for larger blades, the self weight of the blade becomes a design driver. This warrants higher design factor of safety in terms of stresses. This project involves downscaling. Therefore, self weight load scaling is not applicable.
3. Population and Sample Effect Sizes: This term comes from fracture mechanics of materials. For homogeneous materials, the larger the sample size, the greater the probability of critical flaw existing in a given sample. This implies that at some level of upscaling it is not adequate to design for constant stress. Instead a reducing stress allowable must be adopted. This is equivalent to mass scaling more than cubically [27]. This is significant when the estimated effect sizes are large or are statistically significant. In this case, effect on size will be negligible, since the number of components will only increase three-fold and therefore will not be considered in this project.

4. Lift and Drag Coefficients: For a boundary layer around the airfoil sections of the blade, the Reynold's number characterizes the effect of the boundary layer and it is found that flow around the airfoil and its associated lift and drag coefficients depend not only on shape, but on the size of the airfoil too. This is a minor effect, almost negligible for medium (850 kW to 1,500 kW for land-based) and large wind turbines [27].
5. Wind Shear: It is rate of change of wind speed or direction with distance. The wind speed at a certain height above ground level is given by the power law.

$$v = v_{ref} \left(\frac{z}{z_{ref}} \right)^\alpha \quad (3.2)$$

where v and v_{ref} are the mean wind speeds at the heights z and z_{ref} , respectively. The assumption of a normal wind profile or the power law relation is a common approach used in the wind energy industry to estimate the wind speed v at a higher elevation z using surface (usually at 10 m) or tower measurements of wind speeds v_{ref} at reference height z_{ref} . The shear exponent α is typically assumed to be equal to 0.2.

With respect to upscaling, wind shear implies that scaling will result in an increase in power from the wind turbine greater than in proportion to swept area or diameter squared because, as hub height increases, the associated wind speed is also increasing. However, it should be noted that the increase in wind speed with height will also imply an increase in loads thus diminishing any likely benefits from increased swept area [27]. Wind shear effects will be included in the design of the multi-rotor system.

The scaling method adopted and the above mentioned fundamental scaling issues imply that, in down-scaling the NREL 5 MW baseline wind turbine, the stresses would not be greatly affected and will remain within and above safe limits.

3.3 Aerodynamic Interaction

One of the important factors of wind turbine design is the aerodynamics. A multi-rotor system will require a careful analysis of the aerodynamics due to the interaction of rotors in an array in the same wind field.

Smulders, et.all [28] showed through tunnel testing that for two adjacent rotors with no overlap, the average power output of a two rotor system is slightly higher than that of two single rotors, especially if the spacing of the tips is very small. This is true for the situation of co-rotation as well as counter-rotation. The effects are due to wake rotation, more specifically of the interaction of wake vortices. As regards the forces on the two-rotor system, the test results concluded that the contribution of the axial forces keep the up-wind rotor systems headed out into the wind. If the distance between the rotor plane and yawing axis is too large then the side forces working on the plane tend to turn the rotor out of the wind [28]. The paper suggests that rotors placed adjacent to each other give slightly higher average output power. It should be noted that, these tests were done on 20 cm diameter rotors. Therefore, more study is needed in this area.

Wind tunnel tests conducted by Southwest Research Intitute (SwRI) for Ocean Wind Energy Systems (OWES) on a seven-rotor array of 400 W capacity each showed similar results. It was determined that rotor spacing of as little as 2% of the rotor diameter resulted in little or no blade interaction [26].

These results strengthen the case for multi-rotor arrays being feasible without detrimental aerodynamic interactions. Nevertheless, more work is needed to understand the behaviour of multi-rotor aerodynamics and it may well be a whole study of its own. For the design of the MRWT in this thesis, in consideration of the results of the Sumlders and SwRI study, it is assumed that there will be no effect on energy production, one way or the other, due to changing the number of rotors.

3.4 Other Scaling Facts

For any given design style, nacelle mass is very much determined by turbine torque rating, which scales as the cube of diameter. This implies that with consistent design at the same level of technology development, the scaling exponent of nacelle mass will be cubic. It appears that nacelle mass for commercial turbines scales approximately as the square of diameter, as shown in Figure 3.2. However, the largest turbines deviate substantially from the trend line and, considering only modern large turbines above 80 m, the exponent is seen to be approximately cubic, seen in Figure 3.3.

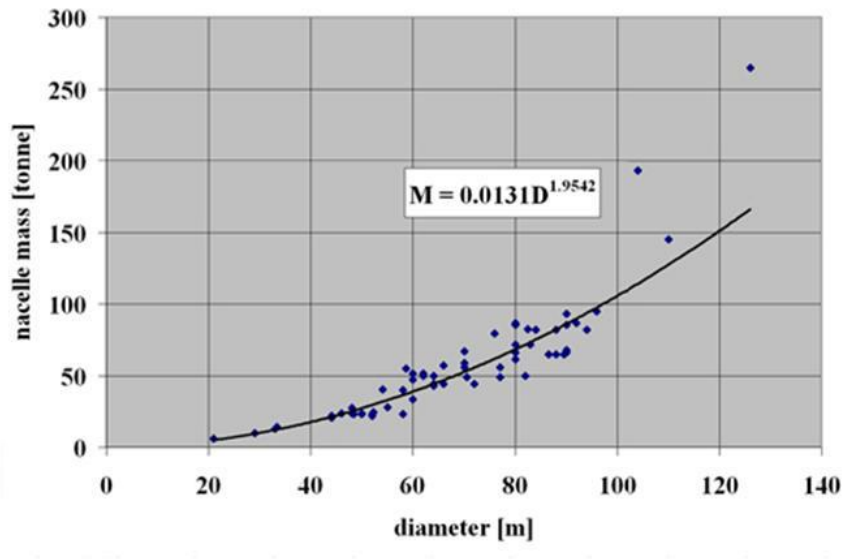

Figure 3.2. Scaling of wind turbine nacelle system mass [3]

Since we are downscaling to three rotors, to a third of the 5 MW capacity each, the rotor diameter will be below 80 m. Would scaling be quadratic, hence improve the design weight? More work is needed in this area before any conclusion is made. If quadratic scaling below 80 m is applicable, a possible adverse effect on stresses must be considered.

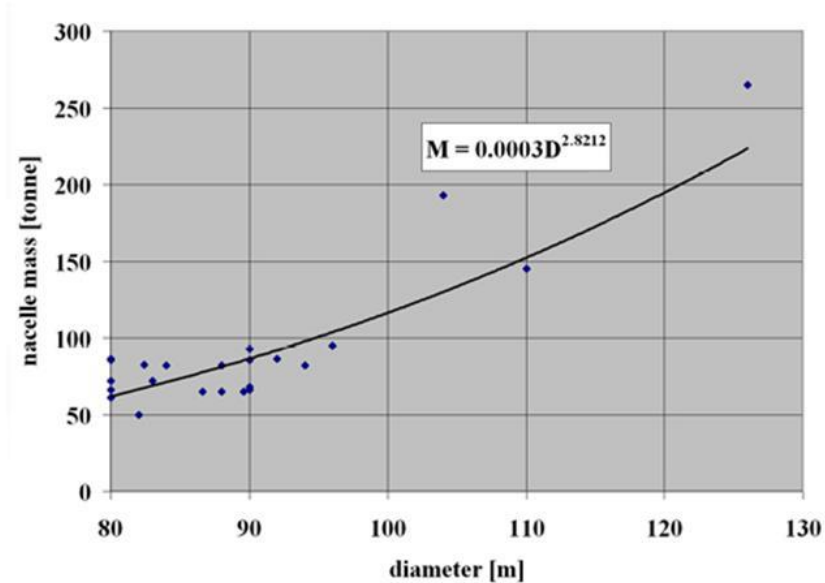

Figure 3.3. Wind turbine nacelle system mass above 80m diameter [3]

3.5 5 MW Three-Rotor Wind Turbine RNA Components

This section presents the general framework and design for the RNA of the multi-rotor assembly based on scaling fundamentals. The RNA component weights are obtained using NREL scaling studies.

3.5.1 Properties of Down-Scaled RNA

In the present work, the baseline for comparison purposes is the 'NREL 5 MW Baseline Wind Turbine' [18]. It is a conventional three bladed up-wind representative utility-scale multi-megawatt turbine, and is variable-speed variable blade-pitch-to-feather-controlled. It was chosen for the extensive information about it readily available. Table 3.1 shows the turbine properties. It is a broad design based on information published by various turbine manufacturers with heavy emphasis on the REpower 5 MW machine. The model has been, and will likely continue to be, used as a reference by research teams throughout the world for advanced land- and sea-based wind energy technologies [18].

Table 3.1. Properties of NREL 5 MW baseline turbine

Rating	5 MW
Rotor Orientation, Configuration	Upwind, 3 Bladed
Control	Variable speed, Collective pitch
Drivetrain	High Speed, Multiple Stage Gearbox
Rotor, Hub Diameter	126 m, 3 m
Hub Height	90 m
Cut-in, Rated, Cut-out Wind Speed	3 m/s, 11.4 m/s, 25 m/s
Cut in, Rated Rotor Speed	6.9 rpm, 12.1 rpm
Rated Tip speed	80 m/s
Overhang, Shaft Tilt, Precone	5 m, 5°, 2.5°
Rotor Mass, Nacelle Mass	110,000 kg, 240,000 kg
Tower Mass	347,460 kg
Coordinate Location of Overall CM	-0.2 m, 0.0 m, 64.0 m

For the purpose of design, the 5 MW MRWT is designed as a system of three downscaled rotors, making each rotor of 1.67 MW power capacity. Properties of the small rotor are shown in Table 3.2. The MRWT is based on the same design conditions as the single rotor NREL baseline machine: i) power coefficient (0.468), ii) mechanical efficiency (100%), iii) electrical efficiency (94.4%) and iv) rated wind speed (11.4 m/s).

Table 3.2. Properties of downscaled 1.67 MW rotor for MRWT

Rating	1.67 MW
Rotor Orientation, Configuration	Upwind, 3 Bladed
Rotor, Hub Diameter	72.75 m, 2 m
Cut-in, Rated, Cut-out Wind Speed	3 m/s, 11.4 m/s, 25 m/s
Cut-in, Rated Rotor Speed	5.51 rpm, 20.94 rpm
Design Tip Speed Ratio, Rated Tip speed	7, 80 m/s

3.5.2 RNA Cost and Weight Scaling

Three scaling studies were analyzed, the NREL model, the WindPACT scaling studies and some scaling relations available from various consolidated sources. Out of these, the NREL scaling model was chosen for two reasons. First of all, the study

proved to arrive at numbers closer to the NREL 5 MW baseline turbine components, especially the blades which contribute mainly towards the cost of the RNA [18]. Secondly, the NREL study is a newer study.

The NREL scaling study was conducted using data available as of 2002 and the results of each study are in 2002 dollars. This was not adjusted as the two assemblies being compared examine the percentage change in cost and weight rather than absolute numbers. Fixed charge costs such as Initial Capital Cost, Annual Operating Expenses etc. were not calculated. As mentioned before, this is a first level analysis and only the turbine component costs were considered.

The NREL scaling study uses two blade mass scaling curves, one for baseline design using the WindPACT model and another for advanced blade design using the LM Glasfiber design curve, as seen in Figure 3.4. It shows the scaling curves for blade mass. The blade mass controls the weight and cost of other rotor components. The advanced blade design curve matches the NREL baseline turbine's blades better. This was not chosen, however, as the design weights of the rotor components aside from the blades did not agree fully with existing 1-2 MW range wind turbine RNA components' weights. Another reason for utilizing the baseline curve is that the advanced blade design curve is in the range of 50 m to 70 m blade radius, and could not be used to scale down below 50 m rotor radius.

Design cost and scaling of the two assemblies (single and multi-rotor) is shown in Table 3.3 using the baseline curve. The multi-rotor wind turbine RNA is almost 20% lighter and 20% cheaper than the single rotor 5 MW NREL baseline turbine RNA (before considering the mass and cost of the multi-rotor support structure). Note: Unless otherwise noted, all dimensions are in meters, all masses are in kilograms and all costs will be in 2002 dollars. The various equations used to determine the weight and cost of the two systems' RNAs are as follows:

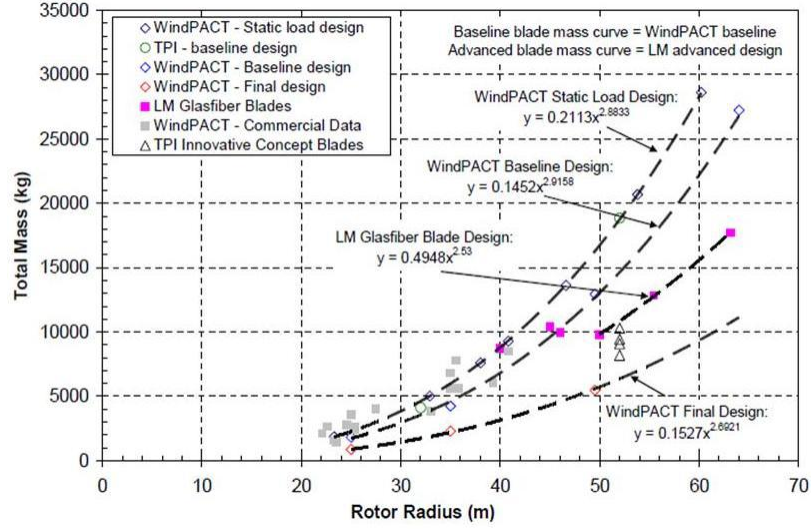

Figure 3.4. NREL study blade mass scaling [11]

$$\text{Blade mass} = 0.1452 * R^{2.9158} \text{ per blade}$$

$$\text{Blade cost} = \frac{[(0.4019 * R^3 - 955.24) BCE + 2.7445 * R^{2.5205} GDPE]}{(1 - 0.28)} \quad (3.3)$$

where R = rotor radius, BCE =blade material cost escalator (assumed 1), $GDPE$ =labor cost escalator (assumed 1)

$$\text{Hub mass} = 0.954 * \text{blade mass/single blade} + 5680.3$$

$$\text{Hub cost} = \text{hub mass} * 4.25 \quad (3.4)$$

$$\text{Total pitch bearing mass} = 0.1295 * \text{total blade mass} + 491.31$$

$$\text{Total pitch system mass} = (\text{Total pitch bearing mass} * 1.318) + 555$$

$$\text{Total pitch system cost} = 2.28 * (0.2106 * \text{Rotor diameter}^{2.6578}) \quad (3.5)$$

$$\text{Nose cone mass} = 18.5 * \text{rotor diameter} - 520.5$$

$$\text{Nose cone cost} = \text{nose cone mass} * 5.57 \quad (3.6)$$

$$\text{Low speed shaft mass} = 0.0142 * \text{rotor diameter}^{2.888}$$

$$\text{Low speed shaft cost} = 0.01 * \text{rotor diameter}^{2.887} \quad (3.7)$$

$$\text{Bearing mass} = (\text{rotor diameter} * 8/600 - 0.033) * 0.0092 * \text{rotor diameter}^{2.5}$$

$$\text{Total bearing system cost} = 2 * \text{bearing mass} * 17.6 \quad (3.8)$$

$$\text{Gearbox mass} = 70.94 * (\text{low speed shaft torque})^{0.774}$$

$$\text{Gearbox cost} = 16.45 * \text{machine rating}^{1.00} \quad (3.9)$$

$$\text{Brake/coupling cost} = 1.9894 * (\text{machine rating} - 0.1141)$$

$$\text{Brake/coupling mass} = \text{brake/coupling cost}/10 \quad (3.10)$$

$$\text{Generator mass} = 6.47 * (\text{machine rating})^{0.9223}$$

$$\text{Generator cost} = \text{machine rating} * 65 \quad (3.11)$$

$$\text{Power electronics cost} = \text{machine rating} * 79$$

$$\text{Electrical connections cost} = \text{machine rating} * 40 \quad (3.12)$$

$$\text{Total yaw system mass} = 1.6 * (0.0009 * \text{rotor diameter}^{3.314})$$

$$\text{Total yaw system cost} = 2 * (0.0339 * \text{rotor diameter}^{2.964}) \quad (3.13)$$

$$\text{Total yaw system mass} = 1.6 * (0.0009 * \text{rotor diameter}^{3.314})$$

$$\text{Total yaw system cost} = 2 * (0.0339 * \text{rotor diameter}^{2.964}) \quad (3.14)$$

$$\text{Hydraulics, cooling system mass} = 0.08 * \text{machine rating}$$

$$\text{Hydraulics, cooling system cost} = \text{machine rating} * 12 \quad (3.15)$$

$$\text{Nacelle cover cost} = 11.537 * \text{machine rating} + 3849.7$$

$$\text{Nacelle cover mass} = \text{nacelle cost}/10 \quad (3.16)$$

$$\text{Mainframe mass} = 1.295 * \text{rotor diameter}^{1.953}$$

$$\text{Mainframe cost} = 9.489 * \text{rotor diameter}^{1.953} \quad (3.17)$$

Table 3.3. 3RWT RNA components' scaled costs and weights using the baseline curve

Component		Cost Summary (\$)		Weight Summary (kg)	
		Single-rotor	Multi-Rotor	Single-Rotor	Multi-Rotor
Rotor	Blades	778,745	506,086	76,843	46,473
	Hub	127,995	135,232	30,116	31,819
	Pitch	183,552	127,907	14,423	11,615
	Nose	10,084	13,792	1,811	2,476
	Total	1,100,375	783,017	123,193	92,383
Nacelle	Shaft	11,582	7,116	16,526	10,148
	Bearing	95,050	41,094	5,401	2,335
	Gearbox	685,772	521,777	36,608	31,201
	Brake	9,947	9,949	995	995
	Generator	325,000	325,065	16,690	18,181
	Power Electronics	395,000	395,079		
	Yaw System	113,954	113,954	13,152	13,152
	Electrical Systems	200,000	200,040		
	Hydraulics	60,000	60,012	400	400
	Nacelle cover	61,535	69,246	6,153	6,925
	Mainframe/Railing	150,732	154,690	31,773	32,608
	Total	2,108,570	1,898,020	127,699	115,944
	Total RNA	3,208,945	2,681,037	250,891	208,327

The total RNA mass of the single rotor NREL baseline machine in Table 3.1 is 350 tonnes, which is approximately 100 tonnes more than the predicted value in Table 3.3. Most of the difference seems to be in the nacelle mass. The rotor masses are similar to each other. For this reason the nacelle mass was estimated using a WindPACT scaling study using the scaling relation shown in Equation 3.18 [16]. Table 3.4 shows the revised masses of the two systems. The nacelle mass is 234.6 tonnes (which is approximately the same as the real NREL baseline machine nacelle mass) making the NREL baseline machine's RNA mass 357.8 tonnes. Therefore, the revised mass is used. This scaling relation makes the total weight of the MRWT 224.9 tonnes as shown in Table 3.4. The cost of mainframe/railing and yaw system of the MRWT from the scaling study is excluded as the system will have a single yaw system whose

cost will be included later. This makes the multi-rotor wind turbine RNA is almost 37% lighter and 25% cheaper than the single rotor 5 MW NREL baseline turbine RNA

$$\text{Nacelle mass} = 0.0967 * \text{rotor diameter}^{3.0399} \quad (3.18)$$

Table 3.4. Revised 3RWT RNA components using WindPACT scaling curve nacelle mass

	Cost Summary (\$)		Weight Summary (kg)	
	Single-rotor	Multi-Rotor	Single-Rotor	Multi-Rotor
Total rotor	1,100,375	783,017	123,193	92,383
Total nacelle	2,108,570	1,629,376	234,608	132,526
Total RNA	3,208,945	2,412,393	357,801	224,918

The weight advantage of the multi rotor RNA will be offset to some extent by the weight of the support structure for the three rotors, but it could still be cheaper and lighter than the 5 MW machine. The weight and cost of the yaw system must be determined too, as the support structure and the total weight and loads would govern the yaw bearing selection. The design of the support structure is explained in the following chapter.

CHAPTER 4

SUPPORT STRUCTURE DESIGN

It is required to estimate realistic costs for a feasible yaw system and compatible structure to support three rotors at 90 m effective hub height. There will be space between the rotors, but it will be small, $\approx 5\%$ rotor diameter. As previously noted, this could conceivably result in a slight improvement in power output, but that possible improvement is not taken into account in this study [28]. In this chapter the structural design process of the support frame, the preliminary yaw system and the tower is presented. The key phases of the design process discussed are the objective of the design, the loads and configurations, the scope of the research, and the iterative design process of the whole structure. The scope of the design is as follows.

1. Advantages Considered:

- Reduced blade mass and cost
- Reduced total RNA weight
- Greater average power (due to the possibility to run the rotors at different speeds).

2. Disadvantages Considered:

- Increased mass of steel in the multi-rotor support structure.

Cost/ease of installation, transport, turbine malfunction and dynamics of tower top structure are not included in this design.

4.1 Design Requirement

The main objective is to design a support structure for the 5 MW MRWT and compare the weight and cost of the entire system with the NREL 5 MW baseline wind turbine. In order to maintain a consistent basis of comparison the following specifications are kept same as the NREL 5 MW baseline wind turbine: same tower, three bladed rotors, rotor TSR 7, 90 m hub height, 11.4 m/s rated wind speed, 0.14 wind shear exponent.

4.2 Design Specifications

4.2.1 Material

The material chosen is structural steel alloy ASTM A992 with a minimum yield strength of 345 MPa and minimum tensile strength 448 MPa. It has density 7850 kg/m³, Young's modulus 200 GPa and shear modulus 77 GPa which is less than the material used in the NREL machine, but comparable and only increases the safety factor. Keeping a safety factor of 1.8 the limiting stress for the design is 190 MPa.

4.2.2 Design conditions

The wind regime for load and safety considerations is divided into the normal wind conditions, which will occur frequently during normal operation of a wind turbine, and the extreme wind conditions that are defined as having a 1-year or 50-year recurrence period, as defined in the fundamental wind turbine design standard, IEC 61400-1 [2]. The MRWT is modeled for simplified versions of two IEC design conditions (static analysis with steady wind model):

1. Operating at rated power: This is called the Normal Turbulence Model (NTM).
2. Stationary at maximum wind: This is the Extreme Wind Speed Model (EWM).

The 50 year EWM is chosen for this design.

4.2.3 Design Loads

Table 4.1 summarizes the data based on which the structure is to be designed. Data for a single rotor of the multi-rotor system is shown with that of the NREL baseline machine rotor for comparison purposes. The rated wind speed is 11.4 m/s and the cut-out wind speed is 25 m/s for both systems. The rotor area of each of the MRWT rotors is equal to a third of the 5 MW baseline machine rotor area. The design drivers for the support structure at operating wind speed are: i) axial thrust on each of the three rotors, ii) rotor weight and iii) rotor torque.

The NREL 5 MW baseline wind turbine is variable-speed variable blade-pitch-to-feather-controlled [18]. The same is assumed for the MRWT. Therefore, the thrust force at extreme wind speed of 50 m/s is not considered because it is less than the thrust at rated power as the turbine is stationary and hence only a portion of the rotor area (area of the blades facing the wind) experiences wind force, reducing thrust. However, the extreme wind speed is included in the analysis to verify the thrust on the frame and tower.

Table 4.1. Design data for a single rotor of the multi-rotor system

	Per rotor of MRWT	Single-rotor 5MW wind turbine
Rotor diameter (m)	72.75	126
Rated rotor power (MW)	1.67	5.0
Hub dia (m)	≈ 2	3
Rotor velocity, ω (rpm)	20.94	12.10
Rotor area (m ²)	4,156.77	12,468.9
Power coefficient, C_p	0.468	0.468
Thrust coefficient, C_t	0.69	0.69
Maximum Axial thrust (kN)	228.3	684.8
Rotor Torque (kNm)	714.3	3,945.9
RNA weight (kg)	74,972	357,801

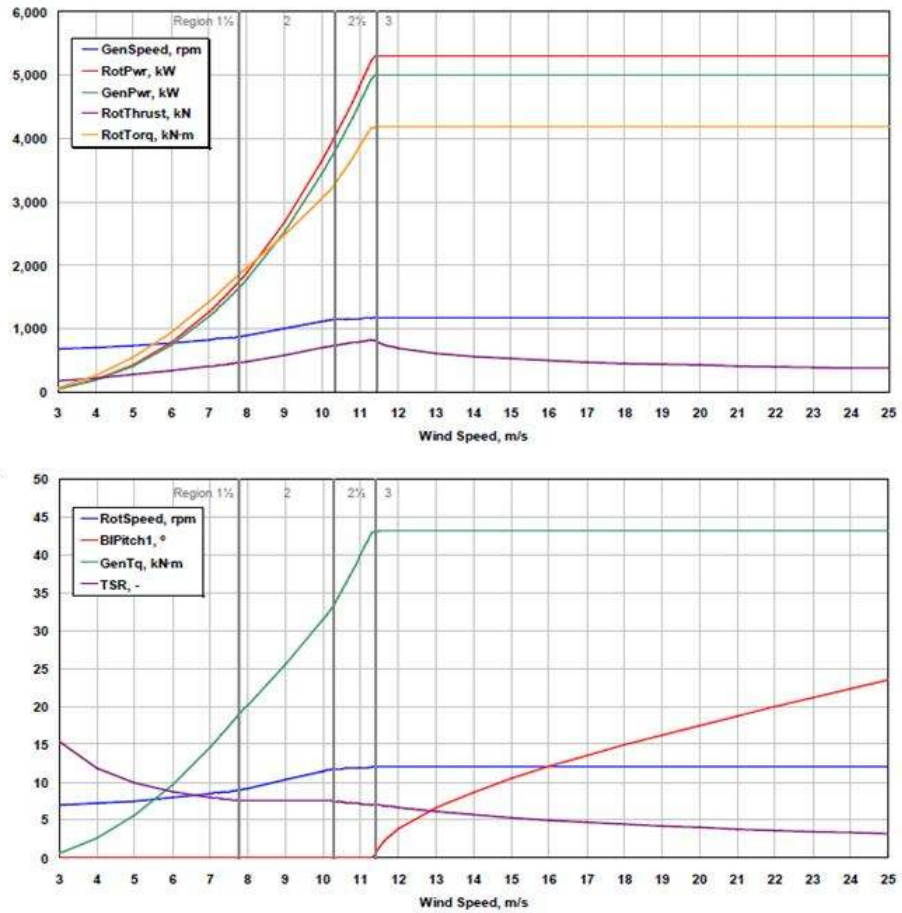

Figure 4.1. NREL baseline machine response curves [18]

Figure 4.1 shows the steady state responses as a function of time for the NREL baseline machine [18]. The maximum rotor thrust, rotor torque, and rotor speed agree with values shown in Table 4.1.

Some points to consider that are inferred from Table 4.1 are: i) the rotor rpm of the multi-rotor system increases, ii) axial thrust remains the same in both cases, iii) rotor C_p is the same in both cases and iv) the total torque is less. Torque on the support frame will depend on the direction of rotation of the multi-rotors and can possibly be further reduced by counter-rotating rotors.

Loading for the design consists of:

1. Dead loads for the weights of the RNAs as well as the structure's self weight.
2. Rotor aerodynamic loads applied as point loads on the structure.

This accounts for only *rotor aerodynamic loads* and the *weight of the RNAs*. The structure frame and tower *drag loads* are also included in the design. These are applied as a steady wind load varying as the shear exponent with height. *Fatigue loads* were not included at this stage. This leaves some uncertainty in whether the structure can withstand these loads but this can be addressed once more information on fatigue loads is available.

4.3 Structural Scheme

The structure will need to withstand bending moments due to thrust from each of the rotors and will also have to support the weight of the RNA corresponding to each of the rotors. Regardless of the specifics, the goal is to hold each of the three smaller RNAs in a manner such that the maximum stresses are within allowable design code limits, the overall mass of the framework is low enough so that the system is not heavier than the 5 MW baseline machine, and also not to be too complex. The yaw

bearing will be assumed to be at the 90 m level on the tower. The design will require several iterations for optimization of the tower top structure.

Two configurations of rotor positions are considered as shown in Figure 4.2. The structural scheme is based on the concept design by Honnef shown in Figure 2.3. The geometric center of the rotor areas is at 90 m hub height for both cases. The swept area of the MRWT is shown in comparison with the NREL baseline machine. Adopting results from the Smulders and OWES tests, radial spacing between rotors is 5% diameter [28] [26].

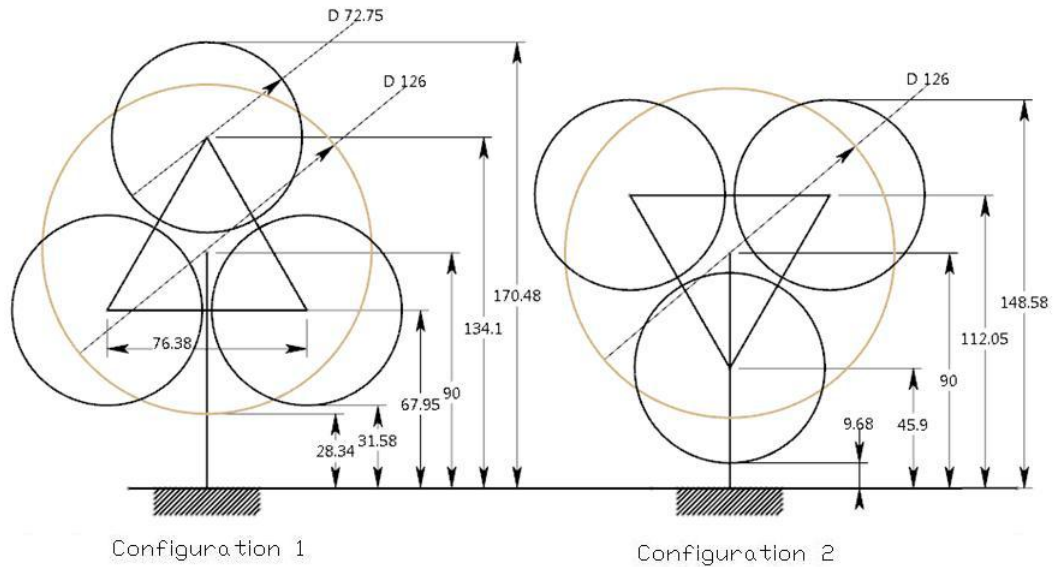

Figure 4.2. Three-Rotor Turbine Configurations

Table 4.2 shows comparisons between the capacity factor (CF) for the single rotor 5 MW turbine, the cumulative CF for Configuration 1 and Configuration 2 and rated power at effective hub height of 90 m. Wind speeds at upper and lower rotors was determined using power law exponents (α) 0.14, 0.2 and 0.25 for annual average wind speeds of 8 m/s and 9 m/s at 90 m effective hub height. The CF was generated using mini codes using Rayleigh distribution for sample 10 minute average wind data and the 5 MW and 1.67 MW wind turbine power curves [19]. The effective CF(cumulative CF of upper and lower rotors) of the MRWT is used to determine the energy output.

As can be seen, there is no significant benefit as compared to the single rotor 5 MW turbine.

Table 4.2. Power Scaling of Rotor Configurations with Shear Exponent

	α	Configuration 1		Configuration 2		Single-rotor	
		CF	Energy kWh	CF	Energy kWh	CF	Energy kWh
8 m/s	0.14	0.418	18,308,766	0.416	18,206,864	0.423	18,527,400
	0.2	0.415	18,191,964	0.412	18,060,561		
	0.25	0.413	18,104,362	0.410	17,958,359		
9 m/s	0.14	0.489	21,433,299	0.487	21,345,827	0.494	21,625,503
	0.2	0.487	21,316,426	0.483	21,170,423		
	0.25	0.485	21,228,825	0.480	21,039,021		

Configuration 1 is chosen for its higher power output at 0.14 shear exponent. Configuration 1 is favourable as it makes more sense structurally as well. The overturning moment on the yaw bearing will be greater in Configuration 2 due to increased thrust loads from the two rotors. Also, the distance between the lower rotor and the ground is too small to be an efficient and safe design.

The tower can be either tubular, or a lattice tower could be used to reduce the weight of the overall system while maintaining stiffness. The height of the overall system will increase; therefore two bearings might be required to accommodate a large overturning moment.

Figure 4.3 shows a basic three-arm support structure designed to hold the three RNAs based on Configuration 1. The 90 m tower is the same as the NREL 5 MW baseline turbine. Tubular steel arms of uniform thickness are used to support the rotors. They have the same material properties as the tower. The whole frame will be supported on a single yaw bearing at the tower top. This makes total tower top weight ≈ 98 tonnes heavier than that of the single-rotor wind turbine. The maximum deflection is 7 m in the thrust direction at the top. The structure requires optimization (possibly by reducing the tower height while maintaining the multi-rotor hub height

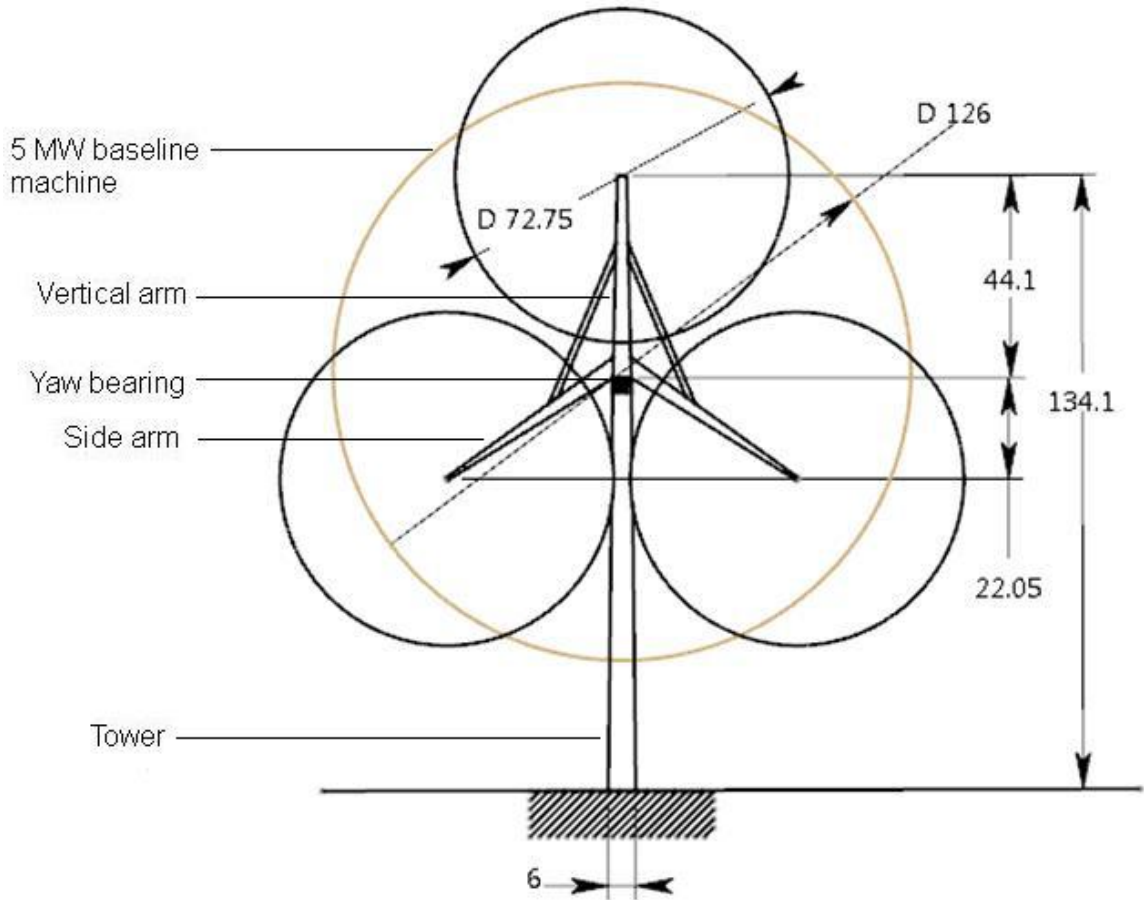

Figure 4.3. Three arm support structure configuration

at 90 m for the assembly, and by improving the design to use trusses/frames), but the concept shows considerable potential for refinement once the full design process is complete.

In order to improve stiffness of the support structure it is designed as a space frame as shown in Figure 4.4. It is modeled using circular hollow structural steel(HSS) frame members. HSS sections are chosen to simplify connections. Only symmetrical sections are used to make alignment easy. The tower, modeled as a non-prismatic frame member, is the same as the NREL baseline machine. The space frame rests on the yaw bearing at the tower top. Two bearings are used to support the part of the support frame below hub height to transfer the torque loads from the space frame to

the tower. The lower bearing is a dummy bearing and not synchronized with the yaw system. The bearings are 22.05 m apart.

The frame is made of round HSS members ranging from 0.1778 x 0.0127 m (7 x 0.5 in) to 0.8636 x 0.0127 m (34 x 0.5in). Keeping the stresses under limits makes the maximum deflection 6 m in y-direction(thrust direction) at the top arm rotor hub. The total weight of the MRWT is 986 tonnes making it 28.2% heavier than the NREL baseline machine. Therefore, this design was not pursued further.

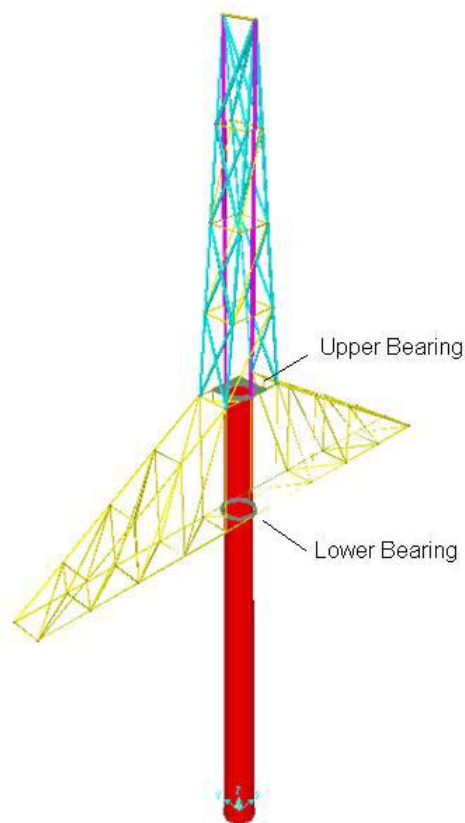

Figure 4.4. Three arm truss type support frame

4.4 Final Design

The three arm space frame described above does not meet the design criteria of deflection around 1 m and limiting stress under 190 MPa. It is also not within the

weight limit of 700 tonnes. It could also be complex to build and erect as it has too many joints. Figures 4.5 and 4.6 shows a simpler design, having fewer members and hence fewer joints. It is based on the concept multi-rotor array system by Capt. Heronemus as shown in Figure 2.5. Similar space frame schemes are also a commonly used occurrence in modern civil engineering structures such as bridges and boarding structures. The space frame is mounted on the same tower as the NREL baseline machine and the support frame rests on the tower using two bearings 22.05 m apart. Figure 4.6 shows the triangular two bearing support frame. The frame member assignments are shown in Figure 4.7.

Slewing bearings are used for heavy duty applications like industrial turntables which makes them ideal for the yaw system. They are available in large diameters, can have integral internal or external gearing, or gearless and are lightweight. However, they are quite expensive. The largest available off the shelf slewing bearings have OD 5 m, weigh about 6 tonnes and cost about \$50,000. Rotek (www.rottek-inc.com/) makes custom bearings upto 9 m OD. Slewing bearings are used in this design as they are lightweight and do not greatly offset the cost benefit from the MRWT system. The upper bearing, mounted at the tower top has ID 4 m. It is synchronized with the yaw system. The lower bearing has ID 4.5 m, is not synchronized with the yaw system and is used only for load transfer.

4.4.1 Analysis

The design is analyzed using SAP2000 [5]. SAP2000 is a state of the art, sophisticated and intuitive, finite element based analysis tool. The tower and support frame are modeled using frame members and the bearings are modeled as shell elements as shown in Figure 4.8. The frames were chosen through a number of iterations to meet allowable weight and stress limits. The joints between frame members are modeled as body constraints with 6 degrees of freedom (DOF), while shell elements

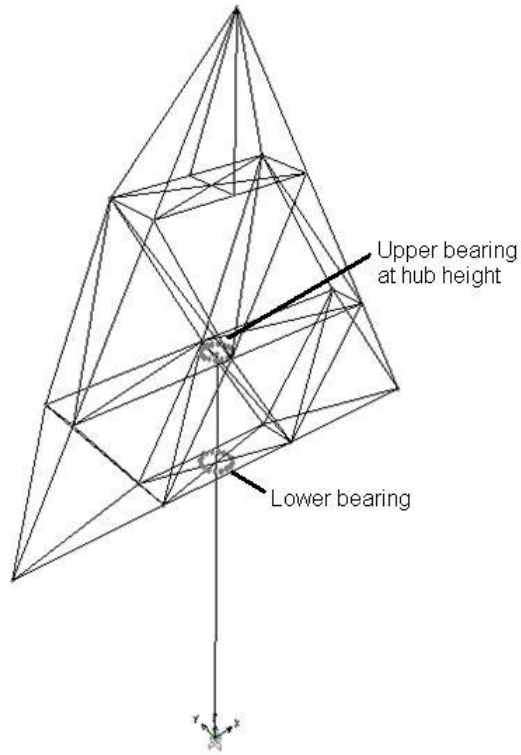

Figure 4.5. Triangular truss type support frame

are constrained with rigid joints. The load factors are 1.2 for dead loads and 1.6 for aerodynamic loads. Load factors are included in the load combination and the overall margin of safety is a combination of these load factors and strength reduction factors used on the strength side of the design equations. Wind drag forces are applied as uniformly distributed loads on all members with shear coefficient of 0.14.

Interactive steel frame design in SAP2000 helps analyze frame design, and revise it based on pre-defined load combinations and resistance factors. Steel frame design code used to analyze the structure is ACI 318-05/IBC2003. Figure 4.9 shows maximum deflection of 990.5 mm in the thrust direction at the topmost point of the top arm, for a dead load (DL) and live load (LL) combination of $1.2DL+1.6LL$. The tovertop (hub height) deflection is 502.7 mm and side arm deflection is 537.9 mm (in the thrust

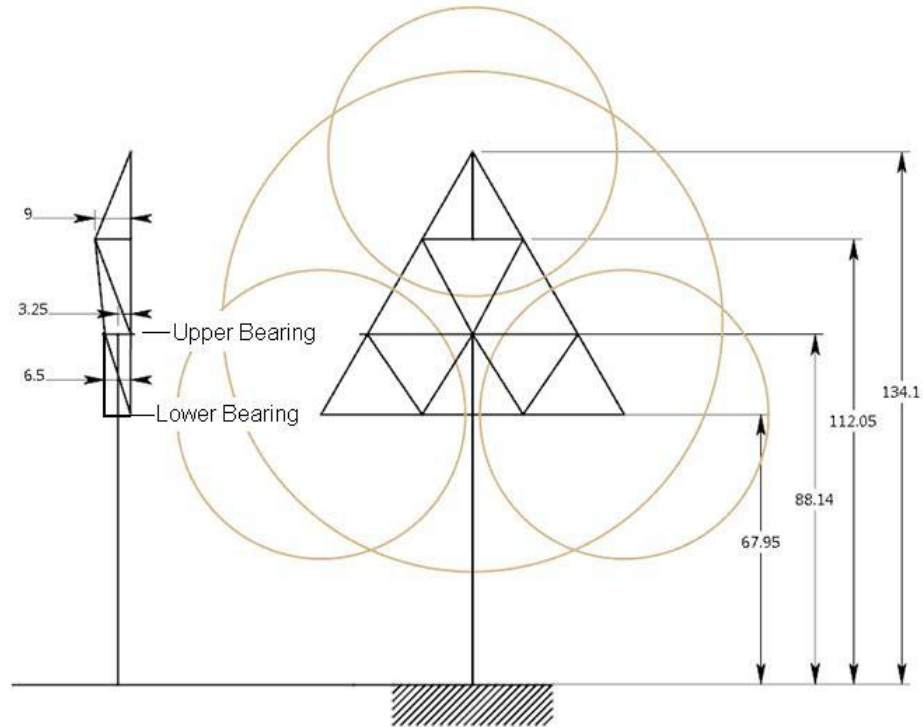

Figure 4.6. Triangular truss type support frame dimensions

direction). Figure 4.10 shows all frame members passed the stress limiting capacity under factored loads.

Using the values of moments, shear and axial forces from the output tables, stresses were calculated for all the frame members including the tower. Maximum stress of 135 MPa occurs in tension in the highlighted frame member shown in Figure 4.11. This is well below the limiting stress set at 190 MPa for the design (margin of safety of 1.8). For comparison, the 5 MW baseline machine model was run using FAST to determine stresses at tower base, tower top and blade root. FAST is a computer-aided engineering (CAE) tool developed by NREL and Oregon State University. It can be used to model both two- and three-bladed, horizontal axis wind turbines [17]. The model was run for four wind speed distributions: parked at extreme wind speed using the Kaimal wind turbulence power spectrum, operating at 12 m/s using Kaimal, Von Karman, and smooth turbulence power spectrum. The overall maximum

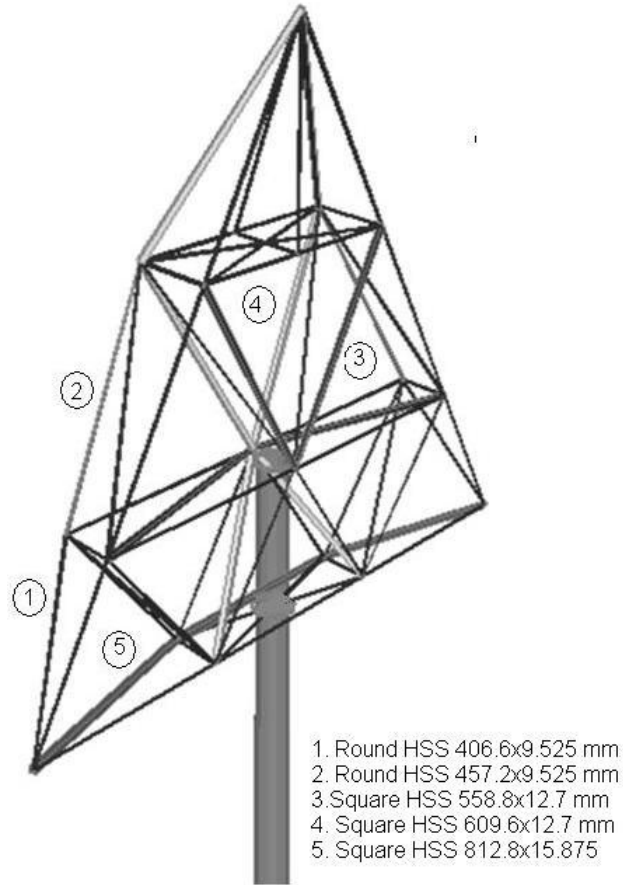

Figure 4.7. Triangular truss frame member assignments

stress is 249.4 MPa and it occurs at the tower base in the parked condition in the thrust direction in bending. The maximum stress in operating condition occurs at the tower base too. It is 116.16 MPa from bending in the thrust direction for the Von Karman wind turbulence model. For the MRWT, the maximum tower base stress is 109.97 MPa due to bending in the thrust direction. Therefore, the maximum stress in the MRWT structure is almost 45% less than the maximum stress in 5 MW NREL baseline machine. It should be noted that the results are of the same order of magnitude, but not identical, due to the different way that the wind conditions are accounted for in the two models (static in SAP2000 and turbulent in FAST).

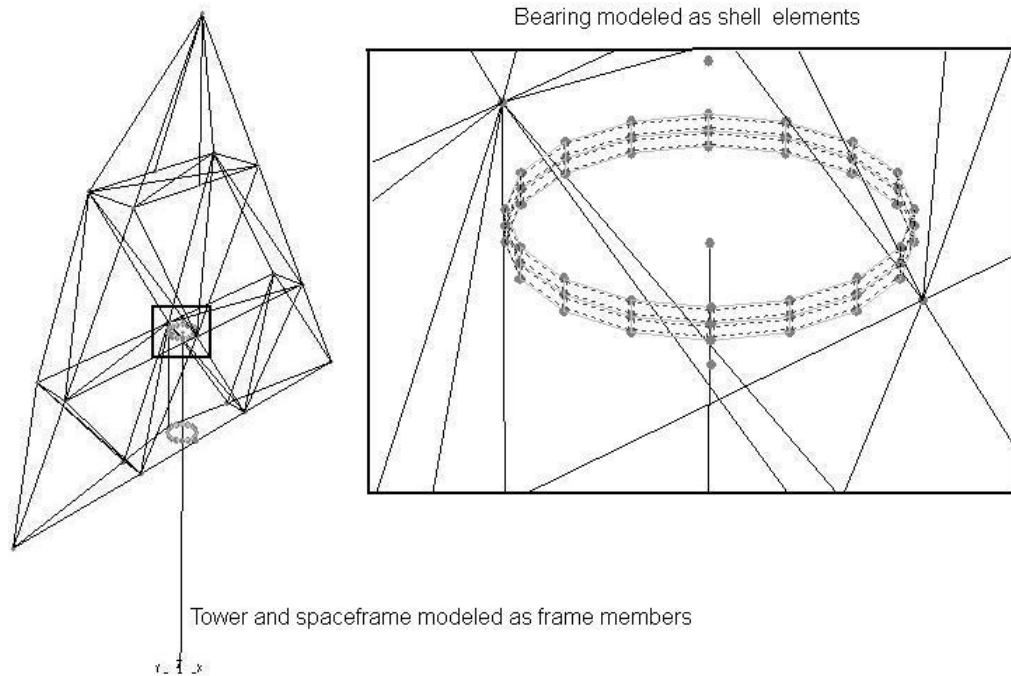

Figure 4.8. SAP2000: Frame members for tower and space frame, shell elements for bearings

Eventually, either SAP or FAST would need to be amended so equivalent comparisons can be made.

Modal analysis is used to determine natural frequencies, mode shapes and damping characteristics of wind turbines while it is being designed. It can be used as a starting point for other, more detailed, dynamic analysis, such as transient dynamic analysis, a harmonic response analysis, or spectrum analysis. Figures 4.12 to 4.14 show the modal shapes. The first natural frequency is 0.33 Hz in the side to side mode, the second natural frequency is 0.35 Hz in the fore and aft mode and the third natural frequency is 0.95 Hz in twisting mode.

4.4.2 Blade Deflection

Blade deflection is an important parameter to consider in the design of the space-frame. The maximum out-of-plane deflection for the NREL machine is approximately

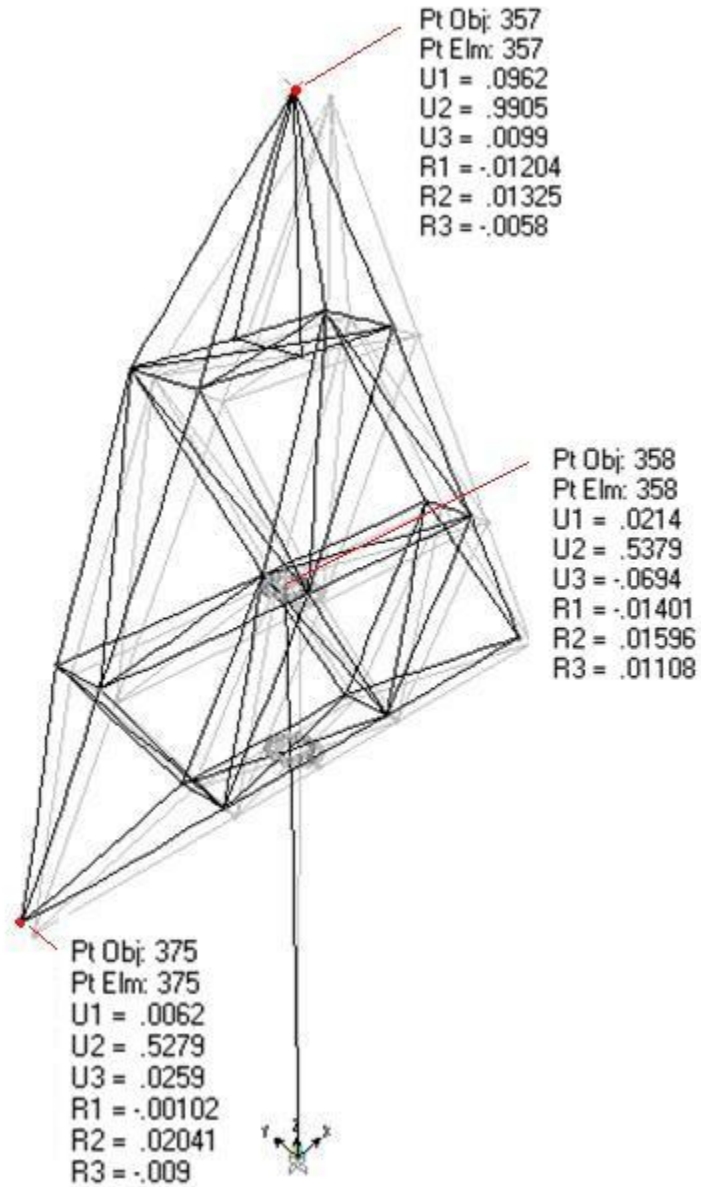

Figure 4.9. Truss type support frame deflections

5.5 m at rated wind speed under dynamic loading [18]. Blade deflection depends primarily on the blade stiffness. It varies as the cube of the diameter, just as weight and cost. This makes the blade tip deflection of the downscaled MRWT rotor to be in the range of 1-1.5 m [1].

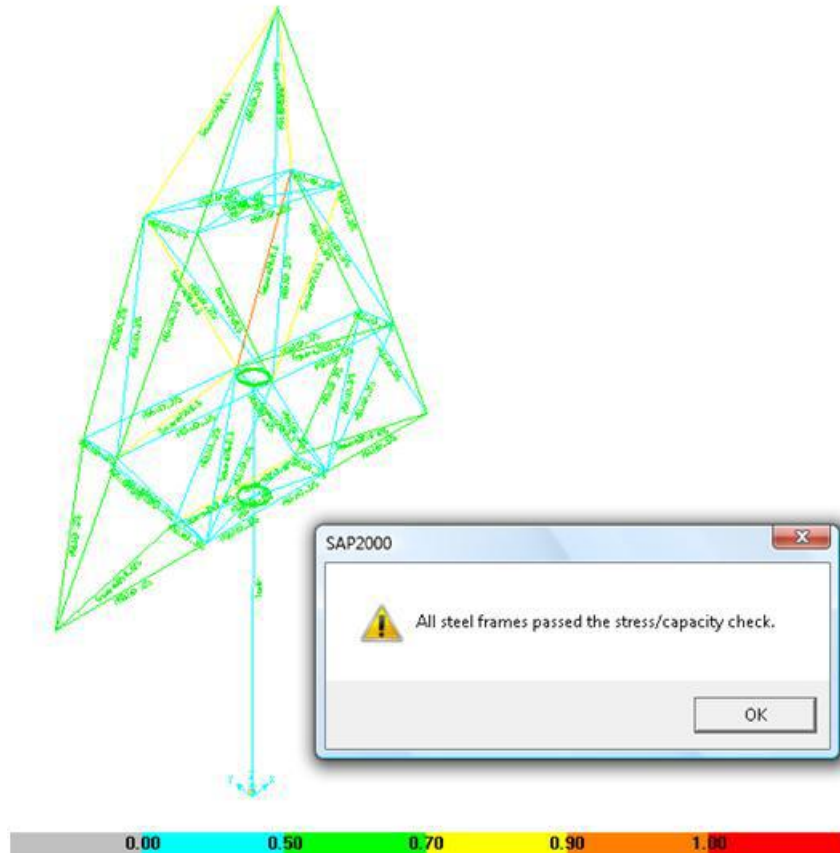

Figure 4.10. Design capacity check

4.5 Weight Summary and Comparison

Table 4.3. MRWT Weight Summary

	Tonnes
3 RNAs	224.92 (74.9 each)
Support Frame	135.6
Tower	328.7
Bearings	11
Total	700.22

The total weight of the MRWT is 700.2 tonnes. Adding another 5% to the weight to account for joints, flanges, access ladder, etc., the total weight is 735.2 tonnes. The total weight of the NREL baseline machine as per Table 3.1 is 697.5 tonnes. This makes the MRWT 5.13% heavier.

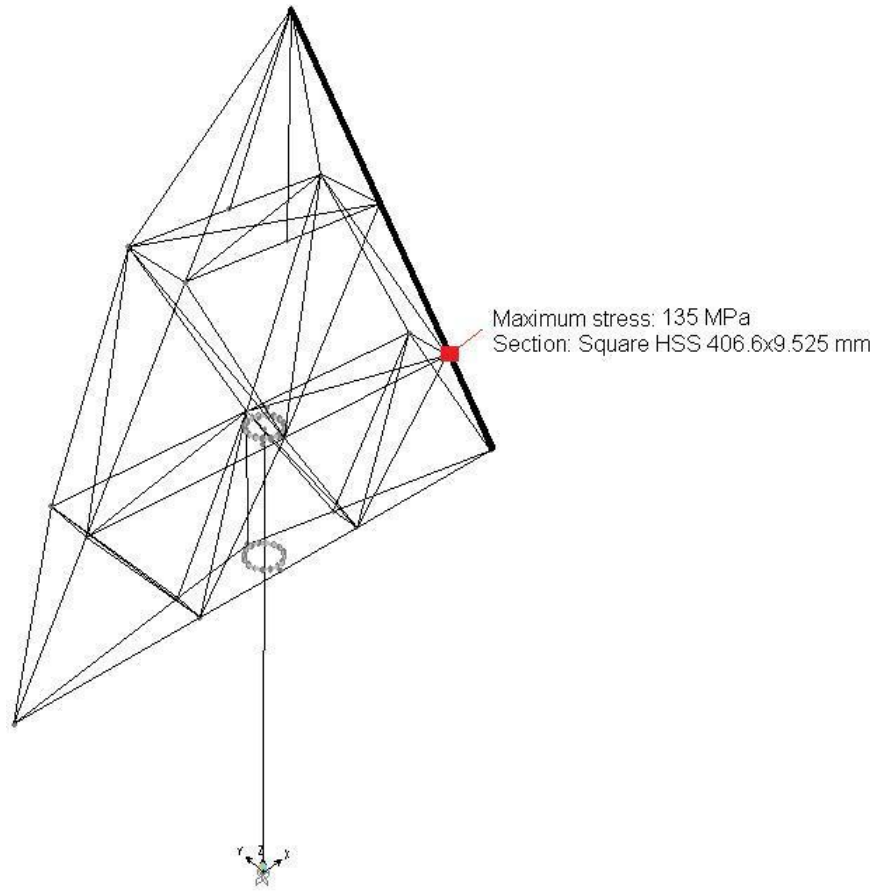

Figure 4.11. Maximum stress in frame member

Table 4.4. MRWT Cost Summary

3 RNAs	\$2,412,393
Support Frame	\$203,400 (\$1.5/kg of steel in 2002 dollars)
Tower	\$493,050 (\$1.5/kg of steel in 2002 dollars)
Bearings	\$130,000
Total	\$3,238,843

The total cost of the MRWT is \$3,238,843 in 2002 dollars as shown in Table 4.4. The cost of the bearings is estimated from Rotek catalog and converted to 2002 dollars at an inflation rate of \$0.27 per \$1 from 2002 to 2012 [12]. The total cost of the NREL baseline machine is \$3,730,150 as per scaling, making the MRWT 13.1% cheaper. This number can be further reduced by design optimization. All steels have approximately the same stiffness. Therefore, the structure can be optimized for

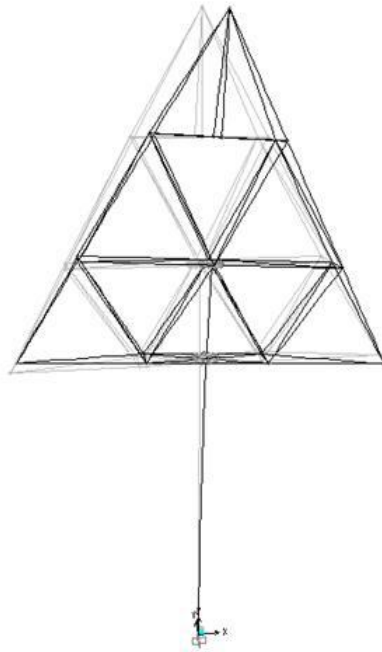

Figure 4.12. First natural frequency, side to side mode

stiffness by exploring other structural configurations, perhaps by using a lattice or hybrid tower as the drag loads on the MRWT system are less than the 5MW baseline machine.

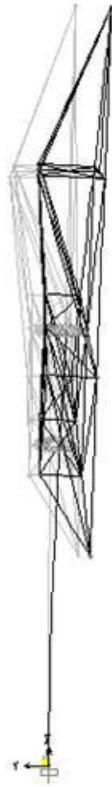

Figure 4.13. Second natural frequency, fore and aft mode

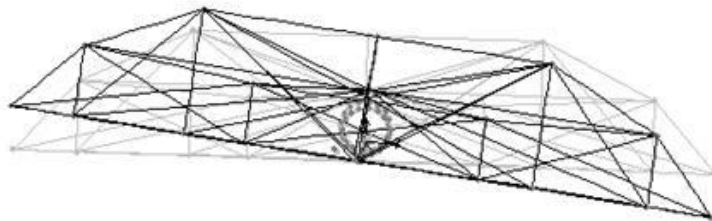

Figure 4.14. Third natural frequency, twisting mode

CHAPTER 5

CONCLUSION

The work presented so far shows how the different scaling techniques are integrated in scaling models such as the NREL and WindPACT studies to provide an overall model. This model helps in determining multi-megawatt wind turbine components' weights and costs. A three rotor wind turbine is designed to compare its cost and weight with a single rotor machine of equivalent capacity. The NREL 5 MW baseline wind turbine is used as reference for comparison. Scaling models downscale the 5 MW baseline machine RNA to three 1.67 MW capacity RNAs.

It has been shown that by using the scaling models the RNA components' weight reduces by $\approx 37\%$ and cost reduces $\approx 25\%$. This is a promising result as the scaling model used is at a preliminary stage and is a crude version of the real situation. These are the preliminary numbers that we have arrived at. Keeping the tip speed ratio constant as scaling requires, the rotational speed of the rotor increases, decreasing torque and reducing load on transmission. Therefore nacelle components like generator, gearbox, etc. will be much lighter than those components in a single rotor turbine, as shown in Table 3.3. The reduced component weight is offset by the support structure weight. The triangular truss support structure described in Chapter 4 makes the tower top weight of the MRWT 5.13% heavier than the single-rotor machine. Despite being heavier, it is 13.1% less expensive than the single rotor machine. The MRWT design is conservative and has great potential for optimization.

It is observed that in transitioning from one rotor to three rotors, the maximum weight advantage is achieved from the downscaled rotor blades. Conversely, the in-

crease in weight arises due to a complex support structure. As a result, an important question that arises is the relation between the number of rotors, the layout and the amount of material required to support them. This optimization study deserves more extensive research.

One of the most important areas to study in the MRWT design is the aerodynamics. It is assumed for this work that the aerodynamics is unaffected by a closely spaced rotor array in a wind field as suggested by Smulders, et al. and the OWES tests. More work is needed to understand the behaviour of multi-rotor aerodynamics and it may well be a whole study of its own. Yawing of an MRWT goes hand in hand with aerodynamics and also merits further study.

The dynamic analysis of the loads on the frame has not been considered. It is possible to use time series outputs from FAST as inputs to SAP at chosen locations on the geometry. This would be a good start to understand the complex 3-d nonlinear dynamics of a MRWT. The frame will be subject to asymmetrical loads, shear, yawing etc. Furthermore, the whole assembly must be validated for a wider range of design cases. Other IEC design conditions should be accounted for to ensure complete, safe design such as extreme operating gust (EOG), extreme turbulence model (ETM), extreme direction change (EDC), extreme wind shear (EWS). Other environmental conditions such as rain, hail, snow, ice, earthquakes, humidity and temperature should be studied too. Different loading scenarios would have to be taken into account in future studies such as startup, shutdown and braking.

The MRWT design developed here uses a most basic approach to modeling MRWT RNA components. Other researchers may develop new ideas from the outline presented here. The main purpose of the MRWT is to reduce the overall cost of the machine. Despite the present limitations and the scarce literature available, the design provides useful predictions and allows inferences about the behaviour of the system. With increased versatility, MRWTs could become useful in some applications.

BIBLIOGRAPHY

- [1] Anonymous. *Parametric Study for Large Wind Turbine Blades*. Technical Report SAND2002-2519, Sandia National Laboratories, August 2002.
- [2] Anonymous. *IEC 61400-1 Ed.3: Wind turbines - Part 1: Design requirements, Final Draft International Standard*. Technical Report 88/228/FDIS, International Electrotechnical Commission, May 2005.
- [3] Anonymous. *Wind Energy The Facts, Rotor and Nacelle Mass*, <http://www.wind-energy-the-facts.org>, 2006.
- [4] Anonymous. *BP Statistical Review of The World Energy, June 2010*, www.bp.com/statisticalreview, 2010.
- [5] Anonymous. *SAP2000 Overview*, <http://sap2000.org/>, 2012.
- [6] Anonymous. *U.S. Department of The Interior, December 2012*, http://www.blm.gov/wo/st/en/prog/energy/wind_energy.html, 2012.
- [7] L. R. Brown. *World on the edge : How to prevent environmental and economic collapse*. W. W. Norton & Company, 2011.
- [8] I. G. Dambolena. *A Planning Methodology for The Analysis and Design of Wind-Power Systems*. PhD thesis, University of Massachusetts, Amherst, U.S.A, January 1974.
- [9] H. Dorner. *Wind Energy History*, <http://www.ifb.uni-stuttgart.de/dorner/ewindenergie1.html>, 1997.
- [10] N. Fichaux, J. Beurskens, P.H. Jensen, and J. Wilkes. *UpWind : Design Limits and Solutions for Very Large Wind Turbines (1st ed)*. 2011.
- [11] L. Fingerish, M. Hand, and A. Laxson. *Wind Turbine Design Cost and Scaling Model*. Technical Report NREL/TP-500-40566, National Renewable Energy Laboratory, CO, December 2006.
- [12] S. M. Friedman. *The Inflation Calculator, Technology*, <http://www.westegg.com/inflation/>, 2012.
- [13] D. A. Griffin. *WindPACT Turbine Design Scaling Studies Technical Area 1 Composite Blades for 80- to 120-Meter Rotor*. Technical Report NREL/SR-500-29492, National Renewable Energy Laboratory, CO, April 2001.

- [14] W. E. Heronemus. Pollution-Free Energy From Offshore Winds. Proceedings of 8th Annual Conference and Exposition, Marine Technology Society. Washington, D.C., U.S.A, 1972.
- [15] P. Jameison and M. Branney. Multi-Rotors: A Solution to 20 MW and Beyond?. Deep Sea Offshore Wind R&D Conference. Trondheim, Norway, 2012.
- [16] P. Jamieson. *Innovation in Wind Turbine Design*. John Wiley & Sons, 2011.
- [17] J. Jonkman. *National Wind Technology Center, Computer Aided Engineering Tools*, <http://wind.nrel.gov/designcodes/simulators/fast/>, 2012.
- [18] J. Jonkman, S. Butterfield, W. Musial, and G. Scott. *Definition of a 5 MW Reference Wind Turbine for Offshore System Development*. Technical Report NREL/TP-500-38060, National Renewable Energy Laboratory, February 2009.
- [19] Jason Jonkman. *National Wind technology Center, Forum*, <https://wind.nrel.gov/forum/wind/viewtopic.php?f=2&t=363>, 2010.
- [20] L. Kroldrup. *Gains in Global Wind Capacity Reported, The New York Times, Green Inc*, February 2010.
- [21] D. J. Malcolm and A.C. Hansen. *WindPACT Turbine Rotor Design Study*. Technical Report NREL/SR-500-32495, National Renewable Energy Laboratory, CO, June 2002.
- [22] J. F. Manwell, J. G. McGowan, and A. L. Rogers. *Wind Energy Explained: Theory, Design and Application (2nd ed)*. John Wiley & Sons, 2009.
- [23] W. Musial, S. Butterfield, and B. Ram. Energy from Offshore Wind. Proceedings of Offshore Technology Conference. Houston, U.S.A, May 2006.
- [24] A. D. Ngo, J. Denault, A. Nakai, T. Morii, S. V. Hoa, and H. Hamada. Design, Manufacturing and Applications of Composites. Proceedings of 8th Joint Canada-Japan Workshop on Composites. Montreal, Quebec, Canada, 2010.
- [25] J. V. Nielsen. *Danmarks Vindkraftshistoriske Samling (Danish Wind Historical Collection)*, http://www.vindhistorie.dk/Faktablade/Faktablad_2a.pdf, 2001.
- [26] D. Ransom, J. J. Moore, and M. Heronemus-Pate. *Performance of Wind Turbines in a Closely Spaced Array*, <http://online.qmags.com/REWNA0510/?pg=7&mode=2>, 2006.
- [27] G. Sieros, P. Chaviaropoulos, J. D. Sorensen, B. H. Bulder, and P. Jamieson. *Upscaling Wind Turbines : Theoretical and Practical Aspects and Their Impact on The Cost of Energy, Wind Energy : The UpWind Special Issue, Volume 15, Issue 1*, January 2012.

- [28] P. T. Smulders, S. Osborns, and C. Moes. Aerodynamic Interaction Between Two Rotors Set Next to Each Other in One Plane. Proceedings of European Wind Energy Conference. Hamburg, Germany, 1984.
- [29] L. Starke. *State of the World: Into a Warming World (1st ed)*. W. W. Norton & Company : New York, 2000.
- [30] F. Stoddard. *The Life and Work of Bill Heronemus, Wind Engineering Pioneer*, <http://www.umass.edu/windenergy/>, 2006.
- [31] P. H. Thomas. Aerogenerator Tower, US Patent No. 2511023, July 1945.