



University of
Massachusetts
Amherst

Yup'ik Antipassive and the ASPP Hypothesis

Item Type	Article
Authors	Benua, Laura
Download date	2026-03-14 10:17:46
Link to Item	https://hdl.handle.net/20.500.14394/50069

Yup'ik Antipassive and the ASPP Hypothesis

Laura Benua

University of Maryland, College Park

1. Introduction*

This paper proposes a theory of phrase structure and case assignment in General Central Yup'ik, an Eskimo language spoken in Alaska. The discussion focuses on the antipassive alternation, illustrated in (1).

- (1) active Kumaggam pingayun qimugtet tanggrai
 K.-ERG three-ABS dog-ABSpl see-ind.3s-3p
 'Kumaggaq sees three dogs'
- antipassive Kumaggaq pingayunek qimugtenek tangertuq
 K.-ABS three-AMpl dog-AMpl see-ind.3s
 'Kumaggaq sees three dogs'

The sentences in (1) differ in case and agreement morphology. The subject of the active clause bears ergative (ERG) case, the object is absolutive (ABS), and the verb agrees with both arguments. In the antipassive, the agent *Kumaggaq* appears in ABS case and the object *three dogs* is in oblique ablative-modalis (AM) case. The antipassive verb agrees only with the ABS-case subject NP.

The case and agreement facts in (1) reflect the different syntactic positions of ABS and AM-case object NPs. Objects of active verbs move to a functional specifier above VP, where structural ABS-case is checked and verb agreement is triggered. Oblique-case objects of antipassives stay inside VP, and do not get structural case or trigger agreement on the verb.

* This paper was written in 1993-94. The Yup'ik data were collected from the literature and from a native speaker of the NSK dialect, Walkie Charles, whom I thank for his patience and enthusiasm. Thanks also to Hagit Borer, who supervised this research, to Kyle Johnson for his useful comments on several drafts, and to Emmon Bach, Elena Benedicto, Angelika Kratzer, Jeff Runner, Lisa Selkirk and the members of the 1994 UMass 2nd year seminar, Satoshi Tomioka, Suzanne Urbanczyk, Tony Woodbury, and Ellen Woolford. All errors are my own.

The antipassive alternation in (1) has an effect on the interpretation of indefinite object NPs, such that ABS-case indefinites are interpreted as specific, and AM-case indefinites are interpreted as nonspecific. Under the Mapping Hypothesis (Diesing 1990), the specificity effect on indefinites follows from the proposal that structural ABS-case NPs are VP-external, and oblique AM-case NPs are VP-internal at Spellout.

In addition to the specificity effect, the antipassive alternation affects the aspectual interpretation of the predicate. Antipassive clauses can get unbounded, non-completive or non-resultative readings which are unavailable to active transitive clauses. These facts are explained by Borer's (1993) ASPP Hypothesis. Borer proposes that the A-movement landing sites above VP are Aspectual Phrases (ASPPs) which encode the Aktionsart of the predicate. I argue that Yup'ik ABS-case objects move out of VP to the specifier of an ASPP which triggers a bounded or telic aspectual interpretation, and that VP-internal AM-case objects fail to move there. The failure of oblique-cased antipassive arguments to move to the "measured event" ASPP is responsible for the non-accomplishment, or non-measured event readings of antipassive clauses.

The paper is organized as follows. The ASPP framework of Borer (1993) is introduced in §2. Then §3 proposes a theory of phrase structure and case checking in transitive Yup'ik clauses, with a focus on the structural contrasts between active and antipassive clauses. In §4 the interpretation effects of the antipassive alternation are discussed, and I argue that the Yup'ik facts provide direct empirical support for the Mapping Hypothesis and Borer's ASPP proposal. Two alternative accounts of the antipassive alternation are addressed in §5, and §6 summarizes and concludes the paper.

2. The Aspect Phrase Hypothesis (Borer 1993)

Borer's (1993) ASPP Hypothesis provides the framework for the analysis of Yup'ik antipassive alternation. Borer's phrase structure, given in (2), includes two Aspectual Phrases (ASPPs) above VP which are dedicated to A-movement. These projections are labelled ASPme for Measured Event and ASPor for Originator. Movement to ASPP results in a particular reading of the moved NP and its predicate.

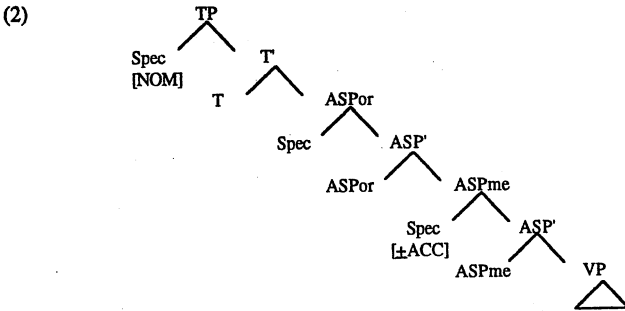

This tree resembles the AGRP structure proposed by Chomsky (1992), in that it has two functional projections that serve as landing sites for argument NPs. Based on her study of NOM-ACC case-marking languages, Borer (1993) places both ASPP projections below TP. However, I will argue that ASPor must be situated above TP in Yup'ik, so that the Yup'ik tree even more closely resembles Chomsky's AGRP structure. There is,

however, an important difference between Chomsky's and Borer's phrase structures: unlike AGRPs, ASPPs affect the interpretation of the predicate, as set out below.

Borer motivates the ASPP phrase structure with a syntactic theory of argument projection. Focusing on projection variability, Borer abandons the lexically-driven approaches that have become standard in GB theory (Williams 1981, Chomsky 1986a, Baker 1988, Belletti & Rizzi 1988; Grimshaw 1990, Speas 1990, Hale & Keyser 1992), and assumes that the hierarchical order of arguments, as well as elements of their interpretation and the interpretation of their predicates, are determined by the projection of NPs into the functional structure of the clause.

2.1. Unergative-Unaccusative Variability

Unergative-unaccusative variability provides strong support for Borer's syntactic argument projection theory, and a convenient starting point for a discussion of the ASPPs in (2). As is well-known, arguments of unaccusative verbs behave syntactically like objects of transitive verbs, while subjects of unergative verbs behave like externally-projected transitive subjects (Perlmutter 1978; Burzio 1986). Syntactic diagnostics like auxiliary selection, *ne*-cliticization in Italian and impersonal passive in Dutch are used to test for the different structural positions of unaccusative and unergative arguments.

Arguments of unergative verbs, like transitive subjects, typically denote Agents of the action, while object-like unaccusative arguments are typically interpreted as Patients or Themes. Unaccusatives and unergatives also have different aspectual interpretations. Unaccusative predicates (*John arrived, the boat sank*) are characteristically telic, inherently specifying the endpoint of the action, while unergative predicates (*John sang, John ran*) are typically atelic (Belletti 1988; Hoekstra & Muldur 1990; Van Valin 1990; Dowty 1991; Levin & Rappaport-Hovav 1993). This aspectual contrast plays a role in variable verb behavior. The Italian sentences in (3) show that the ordinarily unergative verb *run* behaves like an unaccusative in a predicate describing a telic event.

- | | | | |
|--------|---|-----|---|
| (3) a. | Gianni ha corso
Gianni has run
'Gianni ran' | a'. | *Ne hanno corso/i due
of-them have run two
'two of them ran' |
| b. | Gianni e corso a casa
Gianni is run to home
'Gianni ran home' | b'. | Ne sono corsi due a casa
of-them are run two to home
'two of them ran home' |

In the (a) sentences, *run* is unergative; it selects the *have* auxiliary and does not allow *ne*-cliticization of its argument. But in the (b) sentences, *run* behaves syntactically like an unaccusative, selecting *be* and allowing *ne*-cliticization. The difference between the two predicates is the delimiting PP *a casa*, which adds telicity or an endpoint to the running event. Hoekstra & Muldur (1990) claim that this kind of unaccusative variability is productive in Dutch; if the endpoint of an event is expressed, typically unergative verbs like *jump, walk, swim* behave syntactically like unaccusatives.

Volition can also be involved in unaccusative-unergative variability. For example, the impersonal passive in Dutch ordinarily admits only unergative verbs (4). However, typically unaccusative verbs can appear in impersonal passives if volition or intentionality is attributed to the argument NP. Thus, in (5), it is understood that the actor fell on purpose and that the old woman stank intentionally (Hoekstra & Muldur 1990; Dowty 1991).

- (4) dat er werd gesprongen/gewandeld/gezwommen
that there was jumped/walked/swum
'that people were jumping/walking/swimming'
- (5) a. In het tweed dedrijf werd er door de nieuwe acteur op het juiste ogenblik
'In the second act was there by the new actor on cue fallen'
- b. Er werd door de krengen gestonken
'there was by the nasty woman stank'

Borer accounts for the facts in (3-5) by proposing two ASP projections that syntactically encode the aspectual readings associated with unaccusative and unergative predicates, and allowing the projection of intransitive arguments into the specifier of either ASPP to trigger these readings. The Measured Event ASPme is associated with a bounded or telic reading of the predicate, and NPs moved to ASPme are interpreted as event measurers (typically construed as Patients or Undergoers; see §2.2 below on "event measure"). ASPme is the landing site for (definite and specific) direct objects, and for object-like subjects of unaccusative and passive verbs. The higher Originator ASPor projection is associated with atelic aspect and with agentivity or volition. This is the landing site for subjects of unergative predicates. Movement to ASPor results in an atelic reading of the predicate, and an interpretation of the argument NP as an Actor (Van Valin 1990) or Proto-Agent (Dowty 1991).¹

In lexically-driven theories of argument projection, the interpretation of predicates and their arguments follows from specifications in lexical entries and a fixed mapping from lexical entries to syntax (see, e.g., Perlmutter & Postal's (1984) UAH and Baker's (1985) UTAH). Thus, for the alternating intransitive verbs, lexically-based theories require two separate lexical entries, one with the argument specified as a Patient which projects as a sister to V, and one with the argument marked as an Agent that is projected like the subject of a transitive verb.

Borer avoids multiple lexical entries by transferring the burden of argument projection from the lexicon to the syntax. Lexical entries are required only to specify the number of arguments. How arguments project into syntax is linked to the Aktionsart of the predicate. There is no pre-syntactic requirement that the single argument of *fall* be projected as a D-structure sister of V; the lexical semantics of *fall* indicate only that this verb takes a single argument. If the argument NP moves to ASPme, the predicate is unaccusative, with a telic or measured event reading, and the NP is interpreted as an Undergoer of the action (more specifically, as a measurer of the event). If the *fall* predicate describes an intentional event, as in (5a), the argument NP is forced to ASPor to be interpreted as a Proto-Agent, and the predicate behaves syntactically like an unergative.

Borer's theory reverses the relation between theta-roles and syntactic position assumed in traditional lexically-driven theories; she proposes that theta-roles are determined by the syntax, rather than the other way around. Thus, hierarchical structure inside VP is not needed to determine the projection of arguments into the functional clause structure. Borer

¹ Actor and Proto-Agent are not traditional theta-roles. Van Valin (1990) and Dowty (1991) characterize theta roles as clusters of properties defined within each predicate along an Actor/Undergoer or Proto-Agent/Proto-Patient continuum. The non-rigidity of these definitions is attractive, given the notorious difficulty of pinning down precise definitions of traditional theta-role labels. I assume Van Valin's and Dowty's broad, relatively-defined characterizations of theta-roles in my analysis of the Yup'ik facts.

therefore argues that lexical projections like VP have no internal structure, other than being headed by V.²

NP movement out of VP is not entirely free; it is constrained by a post-syntactic interpretational calculus, which matches the (potentially underspecified) lexical semantics of the predicate with the aspectual effects of A-movement, and weeds out nonsensical expressions. For example, a transitive predicate with two Proto-Patients and no Proto-Agent will crash at the interpretive level. While lexical semantics may dictate a preference for an intransitive verb to behave as an unaccusative or an unergative, these preferences can be overridden by syntactic movement.

In sum, Borer argues that unaccusative-unergative variability is aspectually-influenced variation in the projection of intransitive subject NPs into a functional ASPP phrase structure. If the argument of an intransitive verb is projected into [Spec, ASPor], it is interpreted as an agentive argument of an atelic, unergative predicate. If the argument moves to [Spec, ASPme], the event is measured out by the NP, and the predicate behaves syntactically like an unaccusative. Of course, the ASPP projections also serve as landing sites for arguments of transitive predicates. The projection of transitive objects into ASPme, and the notion of "event measure," are discussed in the following section.

2.2. ASPme: Measured Events and the Projection of Object NPs

The "measured event" ASPme projection is the landing site for specific direct objects, and for syntactically object-like passive and unaccusative subject NPs. Movement to ASPme entails a reading of the predicate as an event measured out by the NP in [Spec, ASPme]. The "measured event" notion comes from Tenny (1992), who argues that the direct internal argument of a (nonstative) verb "is constrained to measure out the event [over time] through a [uniform and consistent] change in a single property [of the object]" (1992:3). In the predicate *destroy the city*, the state of the object NP *the city* measures out the event of destroying, and in *ripen the fruit*, the ripeness of *the fruit* measures out the event of ripening.

Tenny's "measure" notion is somewhat unclear to me. It is related to the more familiar aspectual notions telicity and delimitation, which describe temporally or spatially bounded events, but event measure must be independent, because events can be measured without being delimited. For example, the predicate *push the cart* expresses a measured event; the location of the cart measures out the event of pushing. But the predicate *push the cart to New York* is both measured and delimited, since the pushing event ends when the cart is pushed to New York. The indirect argument *to New York* delimits the event by referring to that property of the object (its location) which measures out the pushing event.

Thus, delimited or telic events are necessarily measured, but measured events need not be delimited. Of the aspectual categories proposed by Vendler (1965), accomplishments and achievements are necessarily measured events, although, again, not all measured event predicates can be described as accomplishments (e.g., by Vendler's classification, *push the cart* is an activity predicate). A "measured event," then, appears to be one which can (if the argument NP is a "measurer") be interpreted as having an endpoint. Because "measure" is a somewhat fuzzy notion, I assume that a completive aspectual reading of a predicate is consistent with projection of an argument into ASPme, and that the impossibility of a completive reading indicates that ASPme is not involved in the predicate's syntax.

² Hierarchical structure inside VP may be needed for other reasons, e.g., to account for the behavior of floating quantifiers. In this paper, I assume enough VP-internal structure to assign/check oblique case on arguments left inside VP at Spellout, but I do not explore what the required VP-internal structure might be.

Borer (1993) adopts the Mapping Hypothesis (Diesing 1990), and thereby predicts a connection between the specificity of object NPs and the aspectual interpretation of predicates. Under the Mapping Hypothesis, definite and specific object NPs are forced out of VP to escape unselective Existential Closure, while indefinites remain inside VP, inside the scope of the existential operator. In Borer's phrase structure, definite and specific objects move to [Spec, ASPme], and trigger a measured or completive interpretation of the predicate. Predicates with non-specific objects should be incompatible with a completive reading. The judgments in (6) support this claim. A predicate with a definite object (6a) *caught the fish* is compatible with the accomplishment reading brought out by *in an hour* and marked with the activity adverbial *for an hour*. With the bare plural object (6b) *caught fish*, the judgments are reversed.

- (6) a. I caught the fish in an hour
 ?I caught the fish for an hour
 b. ?I caught fish in an hour
 I caught fish for an hour

This contrast results from object movement, or the lack of object movement, to ASPme. The definite object in (6a) moves to [Spec, ASPme] to escape Existential Closure, triggering the completive or accomplishment reading of the predicate and precluding the activity reading. The bare plural NP in (6b) stays inside VP and is existentially bound and nonspecific. Because the object in (6b) does not move to ASPme, this predicate gets a non-accomplishment reading.

Another interpretive effect related to event measure is "affectedness." According to Tenny (1992:8), affected arguments are those that simultaneously measure out and delimit an event. The affectedness effect is illustrated by the English locative alternation.

- (7) a. John sprayed the paint on the wall. b. John sprayed the wall with paint.
 John loaded the hay onto the wagon. John loaded the wagon with hay.

In the sentences in (7a), the Theme NP appears as the direct internal argument of the verb and the Goal is expressed in a PP. In (7b), the Goal is the direct argument and the Theme is expressed in a PP. This alternation affects the interpretation of the NPs: the direct internal argument, whether it is the Theme or the Goal, is understood to be *entirely affected*, so that the first (a) sentence implies that all of the paint was sprayed onto the wall, while the first (b) sentence implies that the entire wall was covered with paint (Levin & Rappaport 1986a; Speas 1990; Gropen, et.al, 1991). The direct object NP measures out and delimits the spraying event, which ends either when all the paint has been sprayed (7a), or when the entire wall has been sprayed (7b).

The locative alternation demonstrates again the advantage Borer's syntactically-driven argument projection theory has over lexicalist approaches. Lexically-driven theories, with their reliance on a hierarchy of theta-roles, cannot give an adequate account of the locative alternation, since Goals project higher than Themes in one case, and Themes project higher than Goals in the other. Lexicalists must either posit multiple lexical entries for verbs in the spray/load class, or substantially complicate the mapping from lexical conceptual structure to the syntax. Under the ASPP Hypothesis there is no need for multiple lexical entries for verbs of the spray/load class, since arguments are allowed to project freely from an unordered VP. The class of locative alternators are those verbs whose lexical semantics allow the event described to be measured out and delimited by either the Theme or the Goal

argument. The affected arguments in (7), whether they function as a Theme or a Goal, are in [Spec, ASPme].

Importantly, when the argument NP is nonspecific, the affected interpretation disappears. In contrast to (7), the sentences in (8) do not imply that any particular amount of paint was sprayed onto the wall, or that any wall was entirely covered with paint. This is the expected result under the ASPP Hypothesis. Nonspecifics must remain inside of VP to get bound by Existential Closure. Because they do not move to [Spec, ASFme], nonspecific objects cannot measure out events or be interpreted as holistically affected.

- (8) a. John sprayed paint on the wall. b. John sprayed walls with the paint.

Following Tenny and Borer, I assume that measured events are denoted by predicates with a (potentially) completive aspectual interpretation, and that affectedness of argument NPs is also diagnostic of event measure. Admittedly, open questions remain; for example, it is unclear what "event measure" means for non-eventive predicates, such as stative *know the answer*. Borer handles these by allowing the lower ASPP node to be specified [\pm measured event]. In my analysis of Yup'ik antipassives, I focus on eventive predicates, and rely primarily on completive or bounded aspectual interpretation as diagnostic of NP movement to the ASPme projection.

2.3. Summary

By proposing that the structural position of arguments is determined syntactically, rather than by hierarchically-ordered lexical entries, Borer (1993) develops a simple account of variable verb behavior. The ASPP phrase structure is motivated by the correlations between argument projection and aspectual interpretation of predicates. In Borer's phrase structure, the higher Originator ASPor is associated with a Proto-Agent interpretation and atelicity, and is the landing site for unergative subject NPs. The lower Measured Event ASPme, which serves as the landing site for unaccusative subjects and specific direct objects, is associated with a telic or bounded aspect, and may also induce an affected interpretation of the moved NP. Borer's ASPP proposal provides the framework for the analysis of the Yup'ik antipassive alternation developed below.

3. Phrase Structure and Case in Yup'ik

This section sets out a theory of phrase structure and case assignment in Yup'ik transitive clauses. Section 3.1 proposes a structure for simple transitive clauses and a theory of ERG-ABS case-marking. Section 3.2 considers the position of transitive subjects, first demonstrating that ERG-case subjects c-command ABS-case objects, and then arguing for the proposed association of ERG case with the agentive aspect induced by movement to ASPor. Section 3.3 introduces the structure of antipassive clauses, and presents evidence that the oblique case assigned to antipassive object NPs is checked VP-internally.

3.1 Phrase Structure and Case Assignment

Yup'ik is a morphologically ergative language. Intransitive subjects are case-marked like transitive objects with absolutive (ABS) case, rather than like transitive subjects, which get ergative (ERG) case.³

³ Ergative case is called Relative case in most of the Yup'ik literature.

- (9) a. Angutem qimugtet tangrrai 'the man sees the dogs'
 man-ERG dog-ABSp see-ind.3s-3p
- b. Arnaq qavartuq 'the woman sleeps'
 woman-ABS sleep-ind.3s

The subject of the transitive sentence in (9a) appears in ERG case. The object NP in (9a) and the intransitive subject in (9b) both take ABS. ABS case is obligatorily assigned in Yup'ik finite clauses. ERG case never appears on intransitive subjects in Yup'ik, since all intransitive arguments must bear the obligatory ABS case.⁴

Verb inflection also distinguishes the transitive from the intransitive sentence in (9). Transitive verbs agree in person and number with both ERG and ABS arguments, while intransitive verbs agree only with ABS-case subject NPs.

The phrase structure that I assume for Yup'ik is based on Chomsky (1992) and Borer (1993). Like Chomsky, I assume that two functional projections flank TP, and that structural case is checked on, and verb agreement is triggered by, argument NPs in functional Spec-Hd relations. Following Borer, these functional projections are Aspect Phrases (ASPPs), and A-movement into [Spec, ASP] results in a particular reading of the moved NP and the predicate. The basic clause structure, annotated with case features, is given in (10).

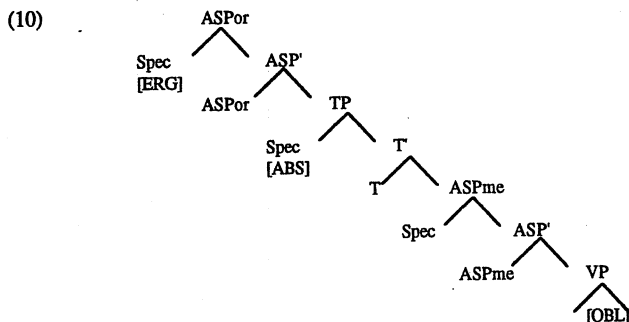

The highest projection, ASPor, is the locus of ERG case-checking. The predicted correlation between ERG case and an Originator interpretation is demonstrated in §3.2.2. The next highest projection, TP, is where ABS case gets checked.⁵ This correctly predicts that ABS case is independent of aspectual effects -- since ABS appears on direct objects and on all intransitive subjects, it must not be tied to any particular aspectual interpretation of the predicate. In the lowest projection, VP, oblique cases are licensed.

⁴ ERG case, like ABS, is a structural rather than a lexical case -- i.e., it is "checked" in a functional Spec-Hd relation, rather than under government by a lexical head (cf. Bok-Bennema 1991). Because ABS case is the obligatory structural case, ERG case appears in Yup'ik only if ABS case is assigned in the same clause. Bobaljik (1993) proposes that a setting of an Obligatory Case Parameter is responsible for the obligatory realization of ABS case in Eskimo languages. However, this OCP must be violable, as it does not hold in all ergative languages; see §3.2.2 for examples of ERG case-marking on intransitive subjects.

⁵ ABS case is checked by features of finite T. This explains why ABS cannot appear in infinitival complement clauses in Yup'ik (Smith 1982; Woodbury 1985; Woodbury & Sadock 1986).

No case is checked in the ASPme projection, which sits between TP and VP. I assume that ASPP projections (like AGRPs) are licensed by A-movement to [Spec, ASP], and that A-movement can be driven by the need for case. Although the ASPme projection has no case-checking ability, it must nevertheless attract argument NPs -- that is, definite and specific objects of transitive predicates must be forced to pass through (and license) ASPme on their way to [Spec, TP] to get ABS case. To prevent object movement directly to TP, I propose that the finite T head is unable to check ABS case without ASP features, and that these features combine via verb movement. Because ABS is obligatory in finite clauses, this ensures that at least one argument will move to the specifier of one of the ASPP projections.⁶

To illustrate the system, (11) sketches the derivation of a simple transitive indicative Yup'ik sentence.⁷

- (11) Angutem qimugtet tangrrai 'the man sees the dogs'
 man-ERG dog-ABSp see-ind.3s-3p

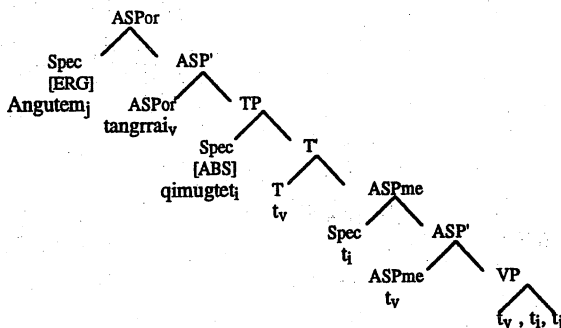

The object NP *qimugtet* 'dogs' moves out of VP to [Spec, ASPme] and on to [Spec, TP]. Movement of the verb through ASPme to T licenses ABS case on the object and triggers object agreement on the verb. The subject *angutem* 'man' moves to the other available A-position, ASPor, where it gets ERG case. The verb moves through each head all the way up to ASPor, where subject agreement is licensed.

3.2. Transitive Subjects: ERG Case in ASPor

In (11), ERG case is checked in the highest functional projection, ASPor. This predicts (i) that ERG-case subjects asymmetrically c-command ABS-case object NPs, and (ii) that there is a correlation between ERG case and an agentive or Originator interpretation.

⁶ Chomsky (1992) also assumes that case is checked by a complex head: object case is checked by AGR-O against features supplied by V, and subjects have case checked in AGR-S against features supplied by T.

⁷ The SVO word order in the tree does not match the sentence above it, which is given in the unmarked ERG-ABS-(OBL)-V (= SOV) word order (Woodruff 1981; Bok-Benemma 1991; Bobaljik 1993). Word order is fairly free in Yup'ik, since case-marking reliably encodes grammatical function. In elicitation sessions, my consultant, who now primarily speaks English, very often gave sentences in the SVO order. Word order is ignored in this discussion.

Section 3.2.1 presents binding data to show that the former claim is correct, and §3.2.2 discusses the association of ERG case with an agentive interpretation.

3.2.1. Hierarchical Order: ERG c-commands ABS

The ERG-case position, ASPor, is above the ABS-case position, TP. The structure thus predicts that ERG subjects asymmetrically c-command ABS-case objects in Yup'ik. Binding facts show that this is correct.

Yup'ik has an anaphoric third person agreement marker, often called the fourth person. When an object NP is inflected for a fourth person possessor, the anaphoric agreement must be bound by a third person subject NP (12a). Anaphoric fourth person agreement cannot mark the possessor of a subject NP (12b); third person possessors of subject NPs must be marked by non-reflexive third person agreement (12c). When pronominal third person agreement marks an object's possessor, the possessor must be disjoint from a third person subject NP (12d).

- (12) a. Kumaggam aana-ni kenkaa
 K-ERG mother-4s-ABS love-ind.3s-3s
 'Kumaggaqi loves his_i/*j mother'
- b. *Aana-ni Kumaggaq kenkaa
 mother-4s-ERG K-ABS love-ind.3s-3s
 'his_i mother loves Kumaggaqi'
- c. Aaniin Kumaggaq kenkaa
 mother-3s-ERG K-ABS love-ind.3s-3s
 'his_i/j mother loves Kumaggaqi'
- d. Kumaggam aaniin kenkaa
 K-ERG mother-3s-ABS love-ind.3s-3s
 'Kumaggaqi loves his_i/*j mother'

If the fourth person possessor marking in (a-b) is anaphoric and subject to Binding Condition A (it must be bound by a c-commanding third person NP in its governing domain) and the third person possessor marker in (c-d) is pronominal and subject to Condition B (it must be disjoint from c-commanding third person NPs in its governing category), then ERG-case subjects asymmetrically c-command ABS-case object NPs in Yup'ik transitive clauses.

3.2.2. ERG Case and ASPor

The ASPP hypothesis predicts that ERG-case NPs, which land in ASPor, are interpreted as Actors or Proto-Agents of the predicate. No evidence from Yup'ik bears directly on this question, so this section adduces evidence of a link between ERG case-marking and agentivity in a number of other languages (see Comrie 1973, Dixon 1979 for general discussion of ERG/agent correlations).

In the Austronesian language Motu and the Australian language Murinypata, ERG case-marking of transitive Actors is optional, and ERG case can be used to disambiguate the roles of two potentially agentive arguments (Dixon 1979:72-73). Similarly, the distribution of ERG case may be related to an Agentivity Hierarchy, so that NPs considered low in agentivity (e.g., inanimates) are more likely to require ERG case marking when they function as Actors than NPs high on the Agentive Hierarchy (Silverstein 1976). For

instance, in some Coast Salish languages, ERG case is required only on Proto-Agents that are outranked by Proto-Patient coarguments (Jelinek & Demers 1983).

Intransitive splits based on agency or volition often involve ERG case, such that volitional intransitive subjects take ERG case, while nonvolitional intransitive subjects get ABS case (e.g., Bats (Caucasian), Dixon (1979); Modern Lhasa and other Tibetan dialects, Delancy (1984, et seq.), Tournadre (1991), Qian (1992)). In Eastern Pomo (Hokan), subjects of intransitive verbs describing uncontrollable events (*sneeze, fall*) always take ABS case, while subjects of intransitives that describe events that must be controlled (*sit, go*) are always ERG. However, many intransitive verbs can appear with either ABS-case or ERG-case subjects, depending on the degree of "protagonist control" implied by the predicate (McLendon 1978; Dixon 1979).

(13) Eastern Pomo (McLendon 1978)

ABS - Nonvolitional

wí c'œ-xélka
'I'm slipping'

wí ba-téc%ki
'I got bumped (accidentally)'

ERG - Volitional

há c'œ-xélka
'I'm sliding'

há ba-téc%ki
'I got bumped (on purpose)'

The interpretive variability in Eastern Pomo can be explained as movement, or lack of movement, of intransitive subjects to ASPor.⁸ These facts suggest that ERG case is linked to an agentive interpretation, and motivate the proposed association of ERG case with ASPor in Yup'ik phrase structure.

It is important to note that ERG case does not entail a volitional reading; indeed, there is no requirement that ERG-case NPs in ASPor be sentient or capable of volition. As mentioned earlier, I adopt a broad interpretation of the "originator" label, along the lines of Van Valin's (1990) Actor or Dowty's (1991) Proto-Agent, which subsume a cluster of properties defined along a Proto-Agent/Proto-Patient or Actor/Undergoer continuum. Thus, arguments that get ERG case in ASPor can have an agentive or volitional interpretation, but they must have a more agent-like or more-volitional interpretation than other arguments in their predicate. This is certainly true of ERG arguments in transitive Yup'ik clauses.

3.3. Antipassive Clauses

Alongside the active transitive construction in (11), Yup'ik has transitive construction known as the antipassive. In the antipassive, the object appears in ablative-modalis (AM) case, the subject is ABS, and the verb bears intransitive inflection. Antipassive sentences have the structure in (14).⁹

⁸ The intransitive splits in Acehnese (Van Valin 1990), Georgian (Harris 1982, Bok-Bennema 1991), Cupeño (Hill 1969), Basque (Bobaljik 1993; Laka 1993), and the active/stative splits in the Sioux languages Dakota and Lakhóta (Van Valin 1985; Legendre & Rood 1992), all of which involve different morphological marking based on volitionality or agency of the NP, can also be given a simple account by assuming a structural position associated with the active/agent-marking morphology and an Originator interpretation.

⁹ In addition to active and antipassive predicates, Yup'ik has a passive construction. The (a) active, (b) antipassive, and (c) passive versions of a transitive sentence are shown here.

(l) a. Kumaggam neqa neraa 'Kumaggaq eats the fish'
K-ERG fish-ABS eat-ind.3s-3s

- (14) Angun qimugtenek tangertuq 'the man sees (some) dogs'
 man-ABS dog-AMp see-ind.3s

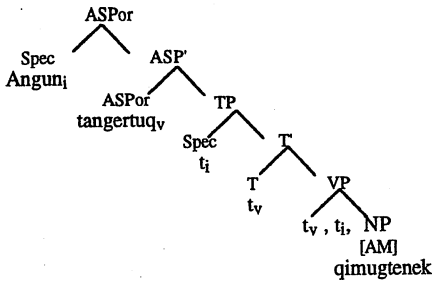

The AM-case object NP does not move out of VP, so it cannot get structural ABS case or trigger agreement on the verb. Obligatory ABS case is realized on the subject NP *angun* 'man'. Unlike ABS-case licensing on transitive objects, which involves a [T + ASPme] head, ABS case is licensed on the antipassive subject NP by a [T + ASPor] head. The subject of the antipassive is projected into ASPor, licensing that ASP projection and triggering an agentive or Originator reading of the NP. The verb moves through T to ASPor, deriving the combination of T and ASP features needed to license ABS case.

The ASPme phrase is not projected in antipassives because it is not licensed by A-movement. Antipassive objects stay inside VP, where they get oblique case, and subjects of antipassives cannot move through ASPme. Because these predicates have a VP-internal Proto-Patient, they must also have a Proto-Agent argument. In the absence of passive morphology, the Actor interpretation can only be licensed in ASPor. Therefore, AM-case (VP-internal) NP *qimugtenek* 'dogs' in the antipassive in (15) cannot be interpreted as an Actor, and this forces movement of the other argument, *angun* 'man', to ASPor. I assume that the antipassive subject cannot move through both ASPPs, since a single NP cannot license both ASPPs. Movement of a single NP through both ASPPs would lead to coindexation of the ASP heads, which is a nonsensical result.¹⁰

- b. Kumaggaq neqmek ner'uq
 K-ABS fish-AM eat-ind.3s
 c. Neqa nerescirtuq Kumaggamun
 fish-ABS eat-PASS-ind.3s K-TM

'Kumaggaq eats a fish'

'The fish was eaten by Kumaggaq'

In the passive, the logical subject (the eater) appears in an oblique case, and the logical object (the thing eaten) appears in the structural subject position, in ABS case. Also, the passive verb is derived with the postbase [+s]ciur-] to get *V-ed*. The antipassive patterns with the active clause: there is no special verb stem morphology, and the logical subject appears in subject position. However, antipassive resembles the passive in that the verb is inflected as an intransitive, agreeing with just one of its arguments. (Note also that other Inuit Eskimo languages do require a verbal postbase to mark antipassive verbs.)

¹⁰ Kyle Johnson pointed out to me that the intransitive subject of the English verb *roll* seems to have both Proto-Agent and Proto-Patient readings simultaneously. While this may indeed be possible, it cannot result from A-movement through both ASPPs. The agentive interpretation of the subject of *roll* could be induced by pragmatic or other extra-sentential factors. Alternatively, because the ASPP system allows for variation in the projection of intransitive arguments, it is possible that the lexical semantics of intransitive

Because no argument NP moves to ASPme in antipassives, these clauses get an unbounded and unaffected reading. Antipassives do not describe measured events. The structural contrast between active and antipassive clauses accounts for both (i) the nonspecific interpretation of indefinite antipassive objects, and (ii) the noncompletive aspectual reading of antipassive predicates. Before turning to a fuller discussion of these facts in §4, the following subsection briefly introduces AM case, and presents evidence which suggests that this oblique case is assigned VP-internally.

3.3.1. AM Case is VP-Internal

Ablative-modalis (AM) is one of five oblique cases in Yup'ik.¹¹ The oblique cases mainly have preposition-like functions. In (15), AM case marks the point of origin NP and terminalis (TM) case marks the destination NP (Jacobson 1993:121).

- (15) Kumaggaq ayallruuq Kuipagmek Kusquqvagmun
 K. ABS go-PST-ind.3s Yukon-AM Kuskokwim-TM
 'Kumaggaq went from the Yukon to the Kuskokwim'

AM case has other functions too.¹² One of these is to mark objects of antipassive verbs. As discussed, the proposal is that AM-case objects of antipassives are VP-internal, and that this accounts for their lack of structural ABS case and for their inability to trigger agreement on the verb. The claim that AM case is associated with VP-internal material is supported by noun incorporation facts.

Yup'ik has many noun-incorporating affixal verbs, including [-ngqerr-] *to have N*, [-li-] *to make N*, [+cur-/+ssur-] *to hunt N*.¹³ (16) shows that when an incorporated noun is modified by apposition, the modifying NP must appear in AM case (Sadock 1980, 1985; Woodbury 1981; Bok-Bennema 1991; Jacobson 1993).

- (16) Malrugnek tungulriigneq qimugtengqertua 'I have two black dogs'
 malruk-gnek tungu-lria-gnek qimugta-ngqerr-tua
 two-AMd be black-Ving one-AMd dog-have N-ind.1s-3d

Here the noun *qimugta* 'dog' is incorporated into the affixal verb *-ngqerr-* 'have', and the modifiers of 'dog' appear in AM case. Without developing a theory of appositional NPs, I assume that they must agree with the NP they stand in apposition to. Since incorporated objects are VP-internal, in the sense that they are not projected into a functional A-position above VP, the fact that the NPs that modify incorporated objects appear in AM case suggests that AM case is assigned/checked VP-internally in Yup'ik. As mentioned earlier, Borer (1993) proposes that VP is internally unstructured, because VP-internal structure is not required to determine the projection of arguments into the functional phrase structure.

roll allow either an ASPme or an ASPor derivation, and that the relatively free variation leads to the judgment that both readings are always available simultaneously.

¹¹ The others are vialis, localis, aequalis and terminalis.

¹² For example, AM case is used to mark the Theme of some ditransitive verbs of giving. With these verbs, the Goal NP is marked ABS, as in (i). With other 'giving' verbs the Theme is ABS and the Goal is TM (Reed et al. 1977).

i. Arnam angun cikiraa akinek 'the woman gave the man some money'
 woman-ERG man-ABS give-ind.3s-3s money-AM

¹³ These affixal verbs are some of the several hundred Yup'ik postbases, many of which are highly productive. Postbases serve a wide variety of functions, few of which are illustrated in this paper. Incidentally, (17) also illustrates another type of postbase, the deverbalizing [-lria-] *one who is V-ing*.

However, there must be sufficient structure inside VP to assign/check oblique case by the (trace of) the V head.

4. The Antipassive Alternation

The proposed structures of Yup'ik active and antipassive clauses are repeated below. In the active sentence (17), the subject NP is ERG, the object NP is ABS, and the verb has transitive agreement. In the antipassive (18), the object is in oblique AM case and the subject is ABS. Because the AM-case antipassive object is VP-internal, it cannot trigger agreement, and the antipassive verb appears with intransitive inflection.

- (17) Active Angutem qimugtet tangrrai 'the man sees the dogs'
 man-ERG dog-ABSp see-ind.3s-3p

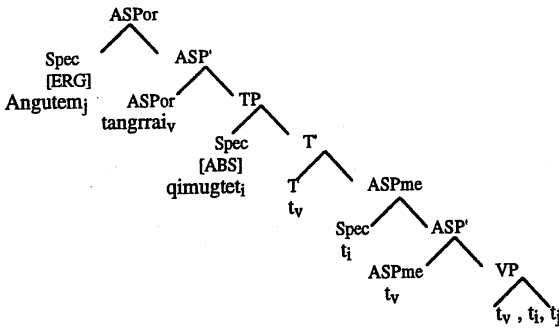

- (18) Antipassive Angun qimugtenek tangertuq 'the man sees (some) dogs'
 man-ABS dog-AMP see-ind.3s

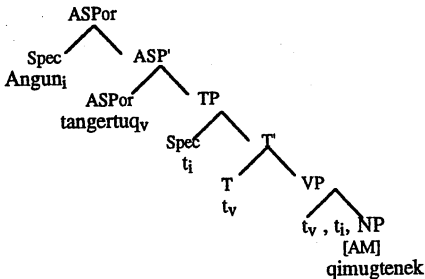

The antipassive alternation affects the interpretation of determiner-less object NPs. It has frequently been noted in the Eskimo literature that the ABS-case object of an active clause is interpreted as definite, while an antipassive AM-case object is indefinite (Kleinschmidt 1851; Bergsland 1955; Woodbury 1977a, 1981; Fortescue 1980; Sadock 1980; Bok-Bennema 1991). However, almost any NP can appear as the AM-case object of

an antipassive verb.¹⁴ NPs with indefinite determiners *two dogs*, *many dogs*, NPs with demonstrative determiners *this dog*, universally quantified NPs *every dog*, and proper names can all appear as oblique-cased objects of antipassive verbs. The data in (19) show active and antipassive versions of sentences with a variety of object NPs.¹⁵

(19)

a. Indefinites 'John saw two dogs'¹⁶ and 'John saw many dogs'

ACTIVE	Caanam (malruk) qimugtek tangellaak John-ERG (two-ABS) dog-ABSd see-PST-ind.3-3d
ANTIPASSIVE	Caanaq (malrugnek) qimugtegnak tangertuq John-ABS (two-AMd) dog-AMd see-PST-ind.3
ACTIVE	Caanam amlleret qimugtet tangellaai John-REL many-ABS dog-ABSpl see-PST-ind.3-3p
ANTIPASSIVE	Caanaq amllerneq qimugtenek tangellruuq John-ABS many-AMpl dog-AMpl see-PST-ind.3

b. Demonstrative determiners 'John saw this dog'

ACTIVE	Caanam una qimugta tangellrua John-ERG this-ABS dog-ABS see-PST-ind.3-3
ANTIPASSIVE	Caanaq uumek qimugtemek tangellruuq John-ABS this-AM dog-AM see-PST-ind.3

c. Universal quantification 'John saw every dog'¹⁷

ACTIVE	Caanam tamalkuita qimugtet tangellruu John-ERG every-ABS dog-ABSpl see-PST-ind.3-3p
ANTIPASSIVE	Caanaq tamalkuitnek qimugtenek tangellruuq John-ABS every-AM dog-AMpl see-PST-ind.3

¹⁴ First and second person pronouns cannot be oblique-cased objects of antipassive verbs (Jacobson 1993:32). This follows from the theory developed here. First and second person pronouns cannot be nonspecific or introduce new discourse referents, and events involving speech-act participants are unlikely to be interpreted as non-resultative. There is, therefore, no interpretation consistent with VP-internal first/second person pronouns.

¹⁵ Most of the Yup'ik sentences presented in this section are given in the past tense, marked with the postbase [-lru-]. These were elicited to avoid the influence of the present tense operator, which often induces a progressive aspect. It should be noted, however, that past tense marking is much less common in Yup'ik than it is in English; Yup'ik predicates unmarked for tense may be interpreted as either past or present tense (Jacobson 1984, 1993; Bittner 1988; Bok-Bennema 1991). This suggests that the present tense operator is not as strong in Yup'ik as it is in English.

¹⁶ Yup'ik NPs are distinctively marked for number, in singular, dual and plural. The numerical modifiers in (20i-ii) are redundant and therefore parenthesized. If present, these modifiers must agree in case-marking with the modified NPs.

¹⁷ The selectional base [tamar-] is ambiguous between the meaning of English *every* and *all* (Jacobson 1993). Note that NPs modified by [tamar-] are marked plural. The base [tamar-] itself can be inflected for number and case, e.g., it can take dual inflection and be glossed as *both of them*, in the independent relative.

(i) Tamarpetek cenirtellruutek 'Both (all two) of you visited'
all-IR.2d visit-PST-ind.2d

I suspect that [tamar-] is closer to English *all* than to *every*, but because I have not discovered another expression of universal quantification in Yup'ik, I assume that [tamalkuita qimugtet] is properly glossed as *every dog*, rather than as *all of the dogs*.

d. <u>Proper Names</u>	'John saw Mary'
ACTIVE	Caanam Mary tangellrua John-ERG Mary-ABS see-PST-ind.3-3
ANTIPASSIVE	Caanaq Mary-mek tangellruuq John-ABS Mary-AM see-PST-ind.3

The antipassive does affect the specificity of indefinite object NPs; in (19a), the antipassive sentences are infelicitous with reference to particular dogs. However, the fact that definite NPs can also be antipassive objects as in (19b-d) shows that definiteness is not the whole story. Definite NPs appear as objects of antipassive predicates because the antipassive alternation has an aspectual effect, such that antipassives get an unbounded or non-completive reading that is unavailable to their active counterparts. Both the aspectual effect of antipassive and the specificity-of-indefinites facts follow naturally from the ASPP hypothesis, because object movement out of VP in transitive clauses is movement to an ASPP projection. Objects that move to [Spec, ASPme] are expected to (i) be definite or specific (not existentially bound) and (ii) trigger a completive or measured event aspectual reading of the predicate.

The following subsections address each of these properties in turn. The specificity effect of antipassive is discussed in §4.1, where I argue that indefinite objects can move to [Spec, ASPme] to escape the existential operator over VP ("Existential closure"), and that this results in a specific interpretation. The aspectual effect of antipassive is discussed in §4.2. I propose that movement of an object to [Spec, ASPme] in an active predicate induces a completive reading that is not available to antipassives, where the object stays inside VP. In §4.3 I discuss two alternative accounts of the antipassive alternation: (i) that the antipassive encodes a given/new effect, so that ABS-case objects are given and AM-case objects are new (Kalmár 1979), and (ii) that the antipassive is used to encode scope (Bittner 1987, 1988, 1994). I argue that the observations on which these theories are based are better explained by the syntactic/aspectual analysis developed here.

4.1. Specificity Effects of the Antipassive

The antipassive alternation affects the interpretation of determiner-less and indefinite NPs, such that the active sentences in (19a) are preferred over the antipassives when particular dogs are being referred to. This is a specificity effect. A specific interpretation of an indefinite object NP results when the NP moves to out of VP into the functional clause structure.

It is well-known that indefinite NPs can get two readings (Milsark 1977). Fodor & Sag (1982) discuss the two possible interpretations of the indefinite subject NP in (21).¹⁸ On one reading, (21) asserts that a particular student cheated; Fodor & Sag call this the *referential* interpretation of the indefinite. On the other reading, the sentence asserts that the set of students who cheated is not empty. This is the *quantificational* reading of the indefinite.

(20) Some/A student in the syntax class cheated on the final exam

More recently, the contrast between the two readings of indefinites has been analyzed in terms of specificity (Enç 1991; Mahajan 1991). Enç's theory is that specific indefinites are

¹⁸ Fodor & Sag discuss only *a student* in the sentence in (21), but their observations also apply to "weak" quantifiers like *some*.

linked (by referential indices) to entities present in the discourse representation.¹⁹ Specific indefinites are distinguished from definites by the strength of the requirements on their link to discourse referents: definites must have an identity relation to a discourse entity, while specific indefinites are only required to be in an inclusion relation with an established discourse element. Nonspecific indefinites, on the other hand, must be both distinct from and unrelated to previously established discourse referents.

Diesing (1990) proposes that the specific/nonspecific interpretation of indefinites is tied to their position in the syntax. Diesing argues that the interpretation of clauses, like the interpretation of NPs as analyzed by Kamp (1981) and Heim (1982), requires formation of a tripartite structure composed of a quantifier, its restrictive clause and a nuclear scope.

- (21)²⁰ [quantifier] [restrictive clause] [nuclear scope]
 Every cat meows
 [every(x)]_Q [x a cat]_{RC} [x meows]_{NS}

The quantifier binds variables in the restrictive clause, while the nuclear scope is bound by an existential quantifier. In the mapping from syntactic structure to semantic representation, the material in the IP area of a clause maps onto the restrictive clause, while material in the VP maps onto the nuclear scope, and is bound by unselective Existential Closure.

Runner (1993) connects the Mapping Hypothesis with the Checking Theory of Case in Chomsky (1992). Checking Theory says that structural case is checked on, and verb agreement is triggered by, NPs in specifiers of functional projections. Putting this together with the Mapping Hypothesis, Runner predicts that when an indefinite object NP bears structural case or triggers verb agreement, it is interpreted as specific. There is much cross-linguistic evidence that Runner's blend of the Mapping Hypothesis with Checking Theory is on the right track. In a variety of languages, a specific interpretation of indefinite object NPs correlates with (i) structural case on the object NP, (ii) agreement morphology on the verb, and (iii) the object's VP-external position.

Case alternations affect the interpretation of object NPs in several languages (Belletti 1988, Enç 1991, de Hoop 1992). In the Turkish and Finnish examples below, object NPs in the (a) sentences are marked with structural accusative case, and receive a definite or specific interpretation. The oblique-case objects in the (b) sentences are interpreted as nonspecific. According to Enç (1991:5), the appropriate glosses for (22) are (a) *A book is such that Ali bought it* and (b) *Ali bought some book or other*.²¹

(22) Turkish (Enç 1991)

- | | |
|---|--|
| a. Ali kitabı okudu
Ali book-ACC read
'Ali read the book' | b. Ali kitap okudu
Ali book-Ø read
'Ali read a book' |
|---|--|

¹⁹ Enç (1991:7, fn.8) equates specificity with the notion of D-linking in Pesetsky (1987).

²⁰ (30) is taken directly from Runner (1993).

²¹ In the Turkish sentences in (22), the contrast is between overt ACC marking and non-overt case. I assume that the non-overt case in Turkish is an oblique case, rather than a structural case. With respect to (23), Belletti (1988:1) says that the partitive-case object in the Finnish sentence (23b) "has an indefinite reading, equivalent to one expressed by a lexical quantifier like *some* in English." Although English *some* is a weak quantifier, ambiguous between specific and nonspecific readings, I assume that the partitive-case NP in (23b) has not only an indefinite, but a nonspecific reading.

(23) Finnish (Belletti 1988)

- | | |
|---|---|
| a. Hän pani kiriat pöydälle
he put books-ACC on the table
'He put the books on the table' | b. Hän pani kiriat pöydälle
he put books-PART on the table
'He put (some) books on the table' |
|---|---|

These alternations are also discussed in de Hoop (1992), for whom case is the determining factor; object NPs that receive accusative case (in her term, a "strong" case) must have "strong" readings. Strong readings include the referential (by which I believe is meant 'reference to a particular entity'), the partitive (or subset) reading, and the generic and collective generic readings. All of these strong readings contrast with the "weak" or existential reading, which is associated with objects bearing a "weak" case like Finnish partitive case.²²

Interpretation of object NPs is also correlated with the presence/absence of verbal agreement. In the Hindi sentence (24a), the masculine object is marked with masculine agreement on the verb, and the object is interpreted as specific. The non-agreeing object in (24b) is nonspecific (Mahajan 1991).

(24) Hindi (Runner 1993 citing Mahajan 1990)

- | | |
|--|---|
| a. siitaa-ne laRkaa dekhaa
Sita-ERG boy-M saw-M
'Sita saw the boy' | b. siitaa laRkaa dekh rahii hE
Sita-ERG boy-M see-prog-be-F
'Sita is looking for a (suitable) boy (to marry)' |
|--|---|

Porteño Spanish allows clitic-doubling, a form of agreement, only with definite and specific object NPs (25a). Nonspecific objects (25b) cannot be doubled.

(25) Porteño Spanish (Suñer 1988)

- | | |
|--|--|
| a. i. La ofan a Paca/ a la niña/ a la gata
her 3PL-listened to Paca/to the girl/to the cat
'They listened to Paca/the girl/the cat' | |
| ii. Diariamente, la escuchaba a una mjuer que cantaba tangos
Daily her 3SG-listened to a woman who sang tangos
'Daily, s/he listened to a woman who sang tangos' | |
| b. i. (*La) buscaban a alguien que los ayudara
(*her) 3PL-searched for somebody who them help-SUBJ
'They were looking for someone who could help them' | |
| ii. (*Lo) alabarán al nino que termine primero
(*him) 3PL-will praise the boy who finishes first
'They will praise the boy who finishes first' | |

A third correlate of object interpretation is position. In many languages, object NPs that are scrambled out of VP are interpreted as definite or specific, while objects that remain inside VP are nonspecific. In Hindi, unscrambled object NPs can get either a definite or an indefinite interpretation (26a). When the object is scrambled, only the definite reading is available (26b) (de Hoop 1992; Mahajan 1991).

²² The use of "partitive" in *partitive case* is the opposite of the use of this term with respect to the *partitive or subset reading*. Partitive case denotes a division, or the result of a division. The subset reading, on the other hand, is presuppositional, denoting membership in a set.

(26) Hindi

- | | |
|--|--|
| a. ilaa-ne anu-ko haar bhejaa
Ila-ERG Anu-DAT jewelry sent
'Ila sent Anu the/a necklace' | b. i. ilaa-ne haar anu-ko bhejaa
ii. haar ilaa-ne anu-ko bhejaa
'Ila sent Anu the/*a necklace' |
|--|--|

Similarly, in Dutch, object NPs inside VP get a nonspecific or existential reading, while objects scrambled to VP-external position have a quantificational or specific interpretation. In (27b), the object is assumed to be outside of VP since it precedes the adverb *yesterday*, and in this sentence, the object gets a partitive (subset) reading glossed as *three of the squatters*.

(27) Dutch (de Hoop 1992)

- | | |
|---|--|
| a. ...dat de politie [vp gisteren drie krakers gearresteerd heeft
that the police yesterday three squatters arrested have
'...that the police arrested three squatters yesterday' | b. ...dat de politie drie krakers [vp gisteren gearresteerd heeft
that the police three squatters yesterday arrested have
'...that the police arrested three (of the) squatters yesterday' |
|---|--|

Thus, case, agreement and position correlate with different interpretations of indefinite and determiner-less object NPs, such that structural case, verb agreement and VP-external position correlate with a specific reading of indefinites, and oblique case, non-agreement and VP-internal position correlate with nonspecific readings of indefinite objects. Languages may make use of more than one syntactic correlate of specificity. In Turkish, for example, case and position work together, and oblique-case (\emptyset -marked) objects cannot scramble out of VP to get a specific interpretation. The object may appear before the adverbial phrase only if it bears accusative case and gets a specific or subset reading *two of the girls* as in (28c).

(28) Turkish (Enç 1991)

- | | |
|---|--|
| a. Daha önce iki kız görmüştüm
more before two girl I-had-seen | 'I had seen two girls before' |
| b. *İki kız daha önce görmüştüm
two girl more before I-had-seen | |
| c. İki kız-i daha önce görmüştüm
two girl-ACC more before I-had-seen | 'I had seen two (of the) girls before' |

In Yup'ik, case and agreement are linked to the interpretation of indefinite object NPs. In active clauses like (29a), the object bears structural ABS case and triggers agreement on the verb, and is interpreted as specific. The AM case object of the antipassive in (29b) does not trigger verb agreement and is interpreted as nonspecific.

(29) Yup'ik

- | | |
|--|---------------------|
| a. Caanam qimugta tangraa
John-REL dog-ABS see-ind.3s-3s | 'John sees the dog' |
| b. Caanaq qimugtemek tangertuq
John-ABS dog-AM see-ind.3s | 'John sees a dog' |

Thus, Yup'ik is one of a number of languages in which the syntax of an indefinite object NP is linked to its interpretation. Under Diesing's Mapping Hypothesis, indefinites

that move out of VP to a functional projection, where they receive structural case and trigger verb agreement, are mapped onto the restrictive clause in the interpretive structure and are understood as specific. Indefinites that stay inside VP get oblique case, fail to trigger agreement, are existentially bound and nonspecific. In Yup'ik antipassives, objects remain inside VP, and if indefinite, are construed as nonspecific.

But what about the definite objects of antipassives in (19b-d)? Why do they remain inside VP at Spellout, instead of moving out to the functional clause structure? Because alongside the specificity effect on indefinites, the antipassive alternation affects the aspectual interpretation of the predicate. In particular, antipassive clauses can get unbounded, nonresultative or unaffected readings that are not available to their active counterparts. This follows directly from Borer's ASPP hypothesis.

4.2. Aspectual Effects of the Antipassive

I have proposed that objects of active clauses move out of VP into functional clause structure; specifically, they move to [Spec, ASPme]. Objects of antipassive predicates stay inside VP at Spellout -- that is, they do not move to ASPme.²³ Antipassive objects therefore fail to measure out events the way their counterparts in active clauses do. This section discusses the non-measure readings of antipassives in Yup'ik and other (related and unrelated) languages.

Unlike active clauses, antipassives do not imply that the action described ever reached its intended result. An illustration of this effect is the discussion of the West Greenlandic Eskimo sentences in (31) provided by Bittner (1988).

- (31) a. Jaakup nuliassani qinirpaa
 J-ERG wife-future-3R-ABS look around for-ind.3s-3s
 Lit. 'Jacob, self's future wife, he is looking around for her'
- b. Jaaku nuliassaminek qinirsivug
 J-ABS wife-future-3R-INS look around for-AP-ind.3s
 Lit. 'Jacob, he is looking around for self's future wife'

The active (31a) sentence is true if Jacob already knows who he is going to marry and he is looking around for that woman. The antipassive (31b) is true if "Jacob feels like getting married but doesn't have a particular woman in mind yet. He's just looking around hoping to find a suitable candidate" (1988:28). These readings clearly involve a specificity effect on the determiner-less object *nuliassani*. Moreover, the last sentence of Bittner's description, about Jacob's *hope* of finding a wife, also implies a non-completive or irrealis reading of the predicate; (20b) implies uncertainty that Jacob ever will find a suitable woman to marry.

²³ Definite NPs must move out of VP at LF to prevent binding of their variables by Existential Closure. This LF-movement affects scope (see §5.2), but does not trigger the completive or "measured event" reading of the predicate. I assume therefore that LF-movement does not put definite objects of antipassives into [Spec, ASPme]. Also, note that nonspecific indefinites (i.e., indefinite objects of antipassives) are also required to move at LF to resolve a type mismatch between the indefinite NP (type <e, t>) and the transitive verb (type <e, <e, t>>) (Partee 1987; Diesing & Jelinek 1993). LF-movement of indefinites could be adjunction to VP. If Existential Closure is defined on the highest VP projection, then VP-adjunction at LF would resolve the type mismatch and still allow AM-case indefinites to be existentially bound and nonspecific.

This sort of non-completive reading of antipassive has been noticed elsewhere. Tarpent (1982) provides an excellent description of a non-measured event in her discussion of the Nisgha (Tsimshian) antipassive. The sentences she discusses, which are translated into Yup'ik in (32), involve proper names rather than indefinite NPs, thereby avoiding the complicating influence of the specificity effect.²⁴

- (32) a. Lucy-m Mary-q utaqallrua
Lucy-ERG Mary-ABS wait for-PST-ind.3s-3s
'Lucy waited for Mary'
- b. Lucy-q Mary-mek utaqallruuq
Lucy-ABS Mary-AM wait for-PST-ind.3s
'Lucy waited for Mary'

Tarpent (1982:80) writes,

Although the English glosses are the same, there is an important meaning difference between the Active sentence and its Antipassive counterpart: [the active sentence] implies not only that Lucy waited for Mary, but that she fully expected Mary to join her, and that Mary did in fact join her after a reasonable amount of time; while in [the antipassive] there is no certainty that Mary did join Lucy, or even that Lucy expected her to do so: Lucy might just have been waiting around on the odd chance that Mary might show up....

In an Antipassive sentence, the action described by the verb occurs, but the goal may or may not be reached; the object may be left undefined; even if it is expressed in the sentence; it may be indefinite in extent; and even where the object is fully specified, as in the examples above, there is no certainty that the goal of the action will be reached.... [T]he process also takes an indeterminate amount of time and may stretch out indefinitely, in contrast to the more or less predictable or at least definable amount of time required to perform the action in the Active sentence.²⁵

Tarpent's observation is explained by the ASPP hypothesis. Because objects of antipassives fail to move to ASPme, they do not measure out the event described by the predicate. In contrast to the "fact" of Mary's arrival implied by the active clause (32a), the antipassive carries no certainty that Mary ever showed up to meet Lucy. This non-resultative reading is possible because AM-case objects fail to move to ASPme to trigger the measured event reading.

Tarpent also notes that active sentences with ABS objects describe events that take place in a definable time period, whereas events described by antipassives may stretch out indefinitely. This too is explained by the ASPme hypothesis: the bounded reading of the active clause is induced by movement of the object to ASPme. The failure of oblique-cased antipassive objects to move to ASPme allows these predicates to get unbounded, or non-measured, aspectual interpretations.

²⁴ Tarpent's Nisgha judgments were confirmed by my consultant for the Yup'ik sentences in (32).

²⁵ In this same passage, Tarpent also notes that the subject of an antipassive does function as an agent or controller of the event, as predicted by my proposal that antipassive subjects move to ASPor. In connection with the sentences in (32), she writes, "[I]n both cases, Lucy did indeed wait.... The indefiniteness of the object and the uncertainty of when, if ever, the goal of the action is reached do not detract from the fact that the action does in fact take place, and that it is controlled by the agent" (1982:80).

The contrast between the accomplishment or measured event reading of active clauses and the unbounded activity reading of antipassives is shown in (33). According to my consultant, active Yup'ik sentences with ABS-case objects are "weird" when modified by the phrase *for an hour*, which biases the predicate toward an activity reading. Antipassives, however, are perfectly acceptable with this modifier.²⁶ (33) shows that the antipassive (b) can be interpreted as an ongoing activity, but the accomplishment reading is preferred for the active clause in (a).

- (33) a. ?Kumaggaq kelaskallrua angyani cass'arlluku
 K-ERG paint-PST-ind.3s-3s boat-3R for an hour
 'Kumaggaq painted his boat for an hour'
- b. Kumaggaq kelaskallruuq angyaminek cass'arlluku
 K-ABS paint-PST-ind.3s boat-3R for an hour
 'Kumaggaq painted his boat for an hour'

Bittner (1987:201) also describes an accomplishment/non-accomplishment contrast in West Greenlandic antipassives. In that language, the verb 'build' *sana-*, "can be interpreted as an accomplishment or as an activity in its transitive form but only as an activity in its - \emptyset antipassive form".²⁷

- (34) a. Jaakup illu taanna sanavaa
 J-ERG house-ABS this-ABS build-ind.3-3
 'Jacob built/was/is building this house (may but need not have finished)'
- b. Jaaku illu-mik taassuminnga sanavuuq
 J-ABS house-INS this-INS build-ind.3-3
 'Jacob was/is building this house (has not finished it yet)'

The antipassive version in (34b) does not admit an accomplishment reading. In the framework proposed here, this follows from the fact that AM-case arguments do not move out of VP to ASPmc.²⁸

The non-measure interpretation of antipassives is also illustrated by the fact that AM-case antipassive objects can be interpreted as non-affected. As discussed earlier, "affected" arguments are those that simultaneously measure out and delimit an event (Tenny 1992).

²⁶ Several weeks after he gave the judgment in (33), my consultant told me that [cass'arlluku] is ambiguous between *for an hour* and *in an hour*. I will assume that in the earlier session, the antipassive was judged incompatible with the *for an hour* reading of the modifier.

²⁷ Bittner (1987) attributes these aspectual effects to the various antipassive suffixes in West Greenlandic, some of which appear to be related to other postbases, e.g., [-lir-] *antipassive* vs. [-llir-] *to begin to V*. In (34), however, there is no overt antipassive morpheme.

²⁸ Unlike West Greenlandic, Yup'ik does not show a non-measure effect in 'house-building' predicates. The most natural way for my consultant to express 'John built the/a house' is with the noun-incorporating verbal postbase [-li-] 'to make N'; e.g., *Caanaq eneliuq*. However, it is possible to obtain the relevant contrast by using this verb with the semantically empty nominal base [pi-] incorporated into it, as in (i). According to my consultant, neither the active nor the antipassive in (i) has an accomplishment reading.

- (i) a. Caanam ena piillrua 'John built the house'
 John-ERG house-ABS it-make-PST-ind.3s-3s
- b. Caanaq en'em'ek piillruuq 'John built a house'
 John-ABS house-AM it-make-PST-ind.3s

(35) shows that AM-case antipassive objects may be interpreted as unaffected. This West Greenlandic example is taken from Bittner (1988:68, fn.6).²⁹

- (35) a. Jaaku-p Aana tuqup-p-aa
 J.-ERG A.-ABS kill-ind-3-3
 'Jacob kills Ann' (Ann is already dead)
- b. Jaaku Aana-mik tuqu-ssi-v-uq
 J.-ABS A.-INS kill-AP-ind-3
 'Jacob kills Ann' (Ann is not dead yet, but almost; she can't be saved)

These aspectual effects fall out of the ASPP proposal. Because AM-case antipassive objects do not move to ASPme, they do not measure out the event described by the predicate. Therefore, non-completive or non-affected readings of antipassives are possible. ABS-case objects of active transitives do move to ASPme and measure out events. Therefore, unaffected readings are not available to ABS-case objects in active clauses.

Similar aspectual effects conditioned by object alternations have been noticed in a variety of languages. According to Van Valin (1977) the active and antipassive versions of the sentence *The dog bites the bone* in the Caucasian language Kabardian differ in completion and/or affectedness of the object NP. The active version of this sentence "implies that the dog bites through to the marrow, while [the antipassive] implies that the dog is just gnawing on it... Ergative [active] constructions emphasize, so to speak, the effect of the action on its [ABS-case] object, whereas accusative [antipassive] constructions highlight the action of the [ABS-case] actor" (Van Valin 1977:698).

The aspectual effects of antipassivization have been noted in Australian languages. For example, Heath (1976:205) remarks that antipassive in Dyirbal suggests "potential" rather than "actualized" activity. Walbiri also uses object case alternations to encode aspectual interpretations. Blake (1977:16) describes the contrast as one between "activity directed towards a goal and activity in which the goal has been achieved." He reports that "Hale (1973:336) notes that in Walbiri, the dative is used to indicate an action that 'is not fully carried out, in the sense that it does not have the intended effect on the entity denoted by the object.'" (Blake 1977:19-20). In the Walbiri sentences in (36), ERG case marks the Actor in both the measured-event predicate (with an ABS-case object) and in the non-measure predicate (with an oblique DAT object). The symbol ϕ denotes a variable AUX constituent (Blake 1977:20).

- (36) a. njuntulu-lu ϕ -npa-tju pantu-nu natju 'you speared me'
 you-ERG ϕ -you-me spear-PST me
- b. njuntulu-lu ϕ -npa-tju-la pantu-nu natju-ku 'you speared at me'
 you-ERG ϕ -you-me-DAT spear-PST me-DAT (you tried to spear me)

Aspectual effects of object alternations have also been reported in NOM-ACC case-marking languages. For example, de Hoop (1992) claims that the Finnish case alternations are associated with different aspectual interpretations of the predicate. When the object NP appears in partitive case, the predicate gets an "irresultative" reading.

- (37) a. Anne rakensi talon b. Anne rakensi taloa
 Anne built house-ACC Anne built house-PART
 'Anne built a/the house' 'Anne was building a/the house'

²⁹ My consultant rejected the idea that the antipassive of the Yup'ik sentence *John killed the/a reindeer* could describe a situation in which the reindeer was not dead.

- (38) a. *Presidentti ampui linnun* b. *Presidentti ampui lintua*
 president shot bird-ACC president shot bird-PART
 'The president shot a/the bird' 'The president shot at a/the bird'

Ramchand (1992) discusses similar measured-event effects in Scottish Gaelic. The verb [iarr-] in (39) can mean either *get* or *want*, depending on the aspectual reading of the predicate. In the progressive (non-perfect) construction (39a), the object appears in the genitive case, while in the perfect clause (39b) the pre-posed object NP is in direct case (the structural case which marks both subjects and objects in this language). The glosses show that the object alternations correlate with the different interpretations of the predicate.³⁰

- (39) a. *Tha mi ag iarraidh a'bhùill*
 Be-PRES I-NOM 'ag' want-VNOUN the ball-GEN
 'I want the ball'
- b. *Tha mi air am ball iarraidh*
 be-PRES I-NOM 'air' the ball-DIR want-VNOUN
 'I asked for (and got) the ball'

The aspectual effects of the object alternations in Yup'ik and other languages are given a simple account under the ASPP hypothesis. If an object NP moves out of VP to ASPme, where it gets structural case and triggers verb agreement, then the object measures out the event described by the predicate. If the object doesn't move out of VP by Spellout, it gets oblique case, does not trigger verb agreement and fails to measure out the event described by the predicate; that is, the lack of object movement to [Spec, ASPme] is manifested as a non-completive or non-resultative interpretation of the predicate. Because ABS-case objects of active transitives move out of VP to ASPme before Spellout, active clauses cannot get a non-measure interpretation.

5. Alternative Accounts

Two alternative analyses of the antipassive alternation have been offered in the Eskimo literature. Kalmár (1979) proposes that AM-case objects of antipassives must introduce new discourse referents. Bittner (1987, 1988, 1994) claims that the antipassive alternation encodes a scope effect, such that ABS-case objects must take wide scope over sentential operators like modals and negation, while AM-case NPs may take narrow scope. This section argues that these authors' observations receive a straightforward account under the proposed theory of antipassivization.

5.1. Given/New Information

Kalmár (1979) reports that proper names appear as AM-case antipassive objects when they introduce new discourse referents, and argues that the 'definiteness effect' of antipassive often noted by Eskimo scholars actually subsumes two effects; a specificity effect and a givenness effect. He argues that ABS-case objects denote specific or given referents, while AM-case objects refer to entities that are newly introduced into the discourse context.

My consultant confirms that there is a givenness effect in the Yup'ik antipassive: AM-case antipassive objects may introduce new referents into the discourse. For example, he

³⁰ Ramchand (1992) also attributes the effect in (39) to an ASPP structure, although her analysis is very different from the one developed here.

offered a scenario in which John and Sam were in a conversation (about anything other than Mary) and Mary walked by the window. In this case, John might utter *I see Mary* as an antipassive with *Mary* in AM case.³¹

- Proper names are definite, and do not introduce free variables into the representation. Proper names, therefore, cannot be nonspecific because there is no free variable that can be bound by Existential Closure. The given/new effect of antipassivization suggest that proper names introduce a variable that is bound to a discourse referent. Following Heim (1982), I propose that variables introduced by proper names are subject to the Novelty Condition, which requires VP-internal proper names to be bound to a new, rather than an established, discourse referent. If the Novelty Condition holds over VP, the given/new effect on proper names in antipassive clauses is predicted.

5.2. Scope

Bittner (1987, 1988, 1994) argues that the antipassive alternation affects the scope of the object NP. ABS-case objects of active transitives must take wide scope with respect to sentential operators like modals and negation, while AM-case objects of antipassives may take narrow scope. Two of Bittner's sentence sets, translated from West Greenlandic to Yup'ik, are presented below.

The example I (40) contains the modal operator *frequently*, represented with the postbase [-lar-] in Yup'ik. The active sentence (40a), with an ABS-case object *arnaq* 'woman', can only mean that John frequently brought home the same woman, while (40b), the antipassive with an AM-case object, allows an interpretation in which John frequently brought home a woman, but it may have been a different woman each time.

(40) 'John frequently brought home the/a woman'

- | | | | | |
|-----|--|-----------|-------------------------------|------------|
| a. | Caanam | arnaq | ut'rutellaraa | (i), *(ii) |
| | Caan-am | arnaq | ut'rute-llru-lar-aa | |
| | John-ERG | woman-ABS | bring home-PST-FREQ-ind.3s-3s | |
| b. | Caanaq | arnamek | ut'rutellartuq | (i), (ii) |
| | Caan-aq | arna-mek | ut'rute-llru-lar-tuq | |
| | John-ABS | woman-AM | bring home-PST-FREQ-ind.3 | |
| i. | $\exists x$ [woman'(x) & FREQ(^[brought home' (j,x)])] (same woman) | | | |
| ii. | FREQ(^ $\exists x$ [woman'(x) & brought home'(j,x)]) (different women) | | | |

Bittner claims that the two interpretations result from the relative scope of the existential quantifier that binds *woman* and the FREQ operator, as shown in (40i-ii). She presents the same sort of argument for scope ambiguity with respect to negation in (41).

(41) 'John didn't eat apples'

- | | | | | |
|----|----------|----------------|-----------------------|------------|
| a. | Caanam | atsarpiit | nerellrunritai | (i), *(ii) |
| | Caan-am | atsarp(ak)-iit | nere-llru-nrite-ai | |
| | John-ERG | apple-ABSpl | eat-PST-NEG-ind.3s-3p | |
| b. | Caanaq | atsarpagnek | nerellrunrituq | (i), (ii) |
| | Caan-aq | atsarpak-nek | nere-llru-nrite-(i)uq | |
| | John-ABS | apple-AMpl | eat-PST-NEG-ind.3s | |

³¹ Proper names can also appear as AM-case objects for other reasons, i.e., without any special emphasis on their introduction into the discourse (see (32)).

- i. $\exists x$ [apples'(x) & NOT (^[ate'(j,x)])] (There are particular apples J. didn't eat)
 ii. NOT (^[$\exists x$ [apples'(x) & ate'(j,x)]] (J. never ate any apples)

The active sentence (41a) can only mean that there is a particular group of apples that John didn't eat. The antipassive (41b) allows the interpretation that John never ate any apples. For Bittner, these interpretations follow from the relative scope of NEG and the existential quantification over apples.

However, the truth conditions of the active and antipassive sentences in (40) and (41) can be explained as a specificity effect, rather than as scope ambiguity. In (40b), the AM-case object *woman* is nonspecific, and so is not tied to the denotation of any single woman, and this allows the interpretation that John brought home a different woman each night. Similarly in (41b), the nonspecificity of the object *apples* makes it possible to understand that John never ate any apples at all. The readings of the West Greenlandic sentences in (42), which Bittner attributes to the relative scope of the modal *must*, also suggest that she is describing a specificity effect on determiner-less objects. The active sentence (42a) is true if there is one particular student that must be helped. The antipassive (42b) may also be true if helping any student will fulfill the speaker's obligation (Bittner 1988:10).

- (42) 'I must help one of them'
- a. *Ilaat* *ikiur-tariaqar-p-ara* (i), *(ii)
 one of them-ABS help-must-ind-1sg/3s
- b. *Ilaannik* *ikiu-i-sariaqar-p-unga* (i), (ii)
 one of them-INS help-AP-must-ind-1sg
- i. I must help some fixed student, for instance, Suulut
 one'(of.them')(λy [MUST(^[help'(i,y)])])
- ii. I must help any odd student, not fixed
 MUST(^[one'(of.them')(λy [help'(i,y)])])

In each of (40-42), the antipassive clause admits two readings, while the active clause has just one interpretation. Under my analysis, ABS-case indefinites in active clauses are obligatorily interpreted as specific, while the indefinite AM-case objects of antipassives are *optionally* specific. This optionality results from the LF-movement of antipassive objects driven by the type mismatch between the indefinite object and the verb (see fn. 23). The judgments in (40-42) suggest that LF-movement of AM-case indefinites can take them into the functional structure of the clause, out of the scope of Existential Closure over VP, resulting in a specific interpretation of the NP. Alternatively, LF-movement can adjoin AM-case objects to VP, where they are existentially bound and nonspecific. ABS-case objects, which move to [Spec, ASPme] at Spellout, cannot lower back down into VP at LF.

To test my hypothesis that the truth conditions of (40-42) reflect a specificity effect on indefinite objects, I questioned my Yup'ik consultant about the readings of the sentences in (43), which have an indefinite subject NP *three boys* and a strongly quantified object NP *every dog*.

- (43) 'Three boys love every dog'
- a. *Pingayun tan'gurraat tamalkuita qimugtet kenkait* *(i), (ii)
 three-ERG boy-ERGpl all-ABS dog-ABSpl love-ind.3p-3p
- b. *Pingayun tan'gurraat tamalkuitnek qimugtenek kenkiut* (i), (ii)
 three-ABS boy-ABSpl all-AMpl dog-AMpl love-HT-ind.3p

- i. Every dog is loved by three boys, but not by the same three boys;
Tom, Dick and Harry love Fido; Sam, Frank and Ted love Rex; etc.
 $\forall y[\text{dog}(y)](\exists x[3\text{boys}(x)](x \text{ loves } y))$
- ii. The same three boys (Tom, Dick and Harry) love every dog.
 $\exists x[3\text{boys}(x)](\forall y[\text{dog}(y)](x \text{ loves } y))$

My consultant's judgment are not what Bittner predicts. The active sentence (43a), with an ABS-case object *every dog*, is compatible only with the narrow scope reading of the object, as in (43ii). The antipassive admits either a wide or a narrow scope reading of the AM-case object *every dog* with respect to the ABS case subject *three boys*.

These scope relations are predicted by the theory of clause structure proposed in this paper. In the active clause (43a), the ERG-case subject NP in ASP or asymmetrically c-commands the ABS-case object NP in TP at Spellout. If the relative scope of VP-external argument NPs is fixed by their Spellout positions (Diesing & Jelinek 1993), it follows that the active clause allows only the reading in which the ERG-case subject *three boys* takes scope over the ABS-case object *every dog*. In the antipassive (43b), the AM-case object *every dog* doesn't move out of VP until LF, via Quantifier Raising (QR), and QR movement by definition affects scope. Thus, the AM-case antipassive object can QR and adjoin to TP, giving it narrow scope with respect to the subject NP (43ii), or it can QR to a higher position, where it gets a wide scope reading (43i).

Bittner (1994) explicitly argues that her data reflect scope rather than specificity. However, following Fodor & Sag (1982), she equates specificity with *widest scope*. Bittner says that the "restrictions [on ABS-case object interpretation] are a matter of scope rather than 'specificity' [as] shown by sentences like (44). Here, the [ABS] argument is contained in a scope island, and is thereby restricted to take scope under the suffixal negation verb which c-commands that island" (1994:138).³²

- (44) Imaa-nngi-laq miiqqat ilaat tammarsimasuq
be.thus-NEG-ind.3s child-ERGpl part-ABS get.lost-PRT-ind.3s
'It is not the case that any of the children got lost'

The ABS-case NP in (44) cannot take scope over negation in the matrix clause. Bittner argues that this means it cannot be specific, since it does not take the widest possible scope. However, under the Mapping Hypothesis, specific does not mean widest scope; specific indefinites are simply those that escape unselective Existential Closure. There is, therefore, no reason to expect the specific ABS-case NP in (44) to take scope over negation in the higher clause.

Moreover, Bittner's assumption that the different interpretations of actives and antipassives result from scope ambiguity forces her to posit an invisible distributive operator in some antipassive clauses. By assuming that a distributive operator is present in antipassives and absent in active clauses, Bittner accounts for the distributive readings available to the antipassives in (45-46). For example, the antipassive in (45) optionally allows the interpretation that two boats were built, one by each man. (Bittner 1994:137).³³

- (45) a. Angutit marluk umiatsiaq ataasiq sanavaat (i), *(ii)
man-ERGpl two-ERGpl boat-ABSs one-ABSs build-ind.3p-3s

³² In (44), the ERG-case NP *child* is a possessor of the NP *someone of*, which appears in ABS case.

³³ This distributive effect is not evident in Yup'ik. My consultant requires the object NP to be marked plural to allow either of the sentences in (45) to mean that two boats were built.

'Two men built one boat'

- b. Angutit marluk umiastia-mik ataatsimik sanapput (i), (ii)
 man-ABSpl two-ABSpl boat-AMs one-AMs build-ind.3p
 'Two men built one boat'
- i. Two men jointly built one boat
 ii. Two men each built a boat

Similarly, the active sentence (46a) can only mean that the mayor addressed a whole group of people with a single speech. This interpretation is unavailable for the antipassive (46b). The antipassive "was judged compatible with two 'distributive' scenarios, both of which were rejected for the [active] transitive (a). In one of these scenarios, there is a group of people and the mayor goes from person to person, shaking hands, and saying something nice to each person in turn. The other scenario is essentially the same except that the people involved were not even gathered in one place; the mayor is going around from house to house with his greetings" (Bittner 1988:22).

- (46) a. Niuirtursuup inuit tamaasa illassivai
 mayor-ERG people-ABS all-ABS greet-ind-3s-3p
 Lit. 'mayor, all people, he greeted them'
 $\exists x[\text{mayor}'(x) \ \& \ \exists y[\text{all}'(\text{people})'(y) \ \& \ \text{greeted}'(x,y)]]$
- b. Niuirtursuaq inunnik tamanik ilassinnippuq
 mayor-ABS people-INS all-INS greet-AP-ind-3s
 Lit. 'mayor, he greeted all people'
 $\exists x[\text{mayor}'(x) \ \& \ \exists y[\text{all}'(\text{people})'(y) \ \& \ D \ \lambda u[\text{greeted}'(x,u)]](y)]$

The logical representations in (46) show that the distributive operator is present in the antipassive and absent in the active clause. I propose that there is no need for an invisible operator in antipassives. The "distributive" readings simply result from the lack of object movement to ASPme in these clauses. If the indefinite object moves out to ASPme and appears in ABS case, it is interpreted as specific, and the predicate is understood to describe a single measured event affecting that specific referent. If the indefinite NP fails to move to ASPme and appears in oblique AM case, it is interpreted as nonspecific and does not measure out an event. This allows the predicate to be interpreted as "distributive," that is, as describing more than one event, each affecting a nonspecific referent.

The interpretive effects described in Bittner's scope-based analysis of antipassive are readily explained under the APSP hypothesis. Antipassive and active clauses differ in the specificity of their determiner-less object NPs and in their aspectual readings. Indefinite objects of antipassives are optionally specific, while indefinites in active clauses are obligatorily specific, and antipassives can be used to describe non-completive events, but active clauses cannot. Because antipassives have a "non-measure" interpretation, they can be used to describe events that never took place, as in (41), or separate, repeated events, as in (45-46), without need for any operators beyond those that are overt in the clause. The ASPP hypothesis is therefore simpler than the scope-based analysis. It also makes correct predictions about (43), where the strongly-quantified object *every dog* must, when ABS in an active clause, take narrow scope with respect to a c-commanding subject *three boys*.

6. Summary and Conclusion

Borer's ASPP phrase structure allows a unified account of the specificity and aspectual effects of the antipassive alternation in Yup'ik. By positing functional projections associated with aspectual interpretations, the specificity effect on indefinites and the non-completive reading of antipassives both follow simply from object movement – or lack of object movement – to the [Spec, ASP] position.

In active transitive clauses, object NPs move to [Spec, ASPme] at Spellout, where they get ABS case and trigger verb agreement. If the object is indefinite, it is interpreted as specific, and (if the predicate is eventive) the object "measures out" the event. In antipassives, object NPs do not move to [Spec, ASPme]; they remain inside VP at Spellout, where they get oblique case and fail to trigger agreement. Consequently, indefinite antipassive objects are nonspecific, and antipassive predicates do not express measured events. Instead, antipassives get non-completive, atelic, or irrealis readings that are unavailable to their active counterparts.

Exploration of two alternative proposals led to further refinement of the analysis. First, my research confirmed that antipassives can be used to encode the novelty of the antipassive object, and I proposed that antipassive objects are subject to a Novelty Condition holding over VP. Second, discussion of the scope-based alternative showed that determiner-less antipassive objects are optionally specific. I proposed that antipassive objects can move out of VP at LF – either by QR or to resolve a type mismatch – and this allows indefinite objects to escape Existential Closure and be specific. This LF-movement is not, however, movement to the canonical object position [Spec, ASPme], which would trigger a completive reading.

Previous studies have shown that indefinite antipassive objects are nonspecific, but no earlier study has explained why strongly quantified NPs can appear as objects of antipassive predicates. Borer's ASPP hypothesis provides the explanation: quantified NPs can be VP-internal antipassive objects because the antipassive alternation – in particular, the syntactic position of the object NP – encodes an aspectual contrast.

References

- Baker, Mark. 1988. *Incorporation: A Theory of Grammatical Function Changing*. Chicago: University of Chicago Press.
- Belletti, Adriana. 1988. The Case of Unaccusatives. *Linguistic Inquiry* 19:1, 1-34.
- Belletti, Adriana and Luigi Rizzi. 1988. Psych-Verbs and Theta-Theory. *Natural Language and Linguistic Theory* 6:291-352.
- Bittner, Maria. 1987. On the Semantics of the Greenlandic Antipassive and Related Constructions. *International Journal of American Linguistics* 53:2, 194-231.
- Bittner, Maria. 1988. *Canonical and Noncanonical Argument Expressions*. Doctoral dissertation. University of Texas at Austin.
- Bittner, Maria. 1994. *Case, Scope, and Binding*. Kluwer Academic Publishers.
- Bittner, Maria and Ken Hale. 1994. The Structural Determination of Case. Ms., Rutgers University and MIT.
- Blake, Barry J. 1977. *Case Marking in Australian Languages*. Canberra: Australian Institute for Aboriginal Studies.
- Bobaljik, Jonathan. 1993. On Ergativity and Ergative Unergatives. MIT Working Papers in Linguistics 19.

- Bok Bennis, Reineke. 1985. On Marked Pronominal Anaphors and Eskimo pro. In J. Guéron, H.-G. Obenauer, J.-Y. Pollock (eds). *Grammatical Representation*. Foris: Dordrecht.
- Bok Bennis, Reineke. 1991. *Case and Agreement in Inuit*. Foris Publications.
- Borer, Hagit. 1993. The Projection of Arguments. University of Massachusetts Occasional Papers in Linguistics 17.
- Burzio, Luigi. 1986. *Italian Syntax*. Dordrecht: Reidel.
- Carrier, Jill and Janet Randall. 1993. Lexical Mapping. In Reuland and Abraham (eds.). *Knowledge and Language* vol.II. Kluwer.
- Chomsky, Noam. 1986a. *Knowledge of Language*. Praeger.
- Chomsky, Noam. 1992. A Minimalist Program for Linguistic Theory. MIT Occasional Papers in Linguistics No.1.
- Comrie, Bernard. 1973. The Ergative: Variations on a Theme. *Lingua* 32, 239-253.
- Comrie, Bernard. 1976. *Aspect An Introduction to the Study of Verbal Aspect and Related Problems*. Cambridge Textbooks in Linguistics.
- DeLancey, Scott. 1981. An Interpretation of Split Ergativity and Related Patterns. *Language* 57:3, 626-657.
- DeLancey, Scott. 1984a. Transitivity and Ergative Case in Lhasa Tibetan. *Proceedings of the Berkeley Linguistic Society* 10.
- DeLancey, Scott. 1985b. Categories of Non-Volitional Actor in Lhasa Tibetan. In A. Zide et al. (eds.), *Proceedings of the Conference on Participant Roles: South Asia and Adjacent Areas*. Bloomington, IN: Indiana University Linguistics Club, 58-70
- DeLancey, Scott. 1990. Ergativity and the Cognitive Model of Event Structure. *Cognitive Linguistics* 1-3, 289-321.
- Diesing, Molly. 1990. *The Syntactic Roots of Semantic Partition*. Doctoral dissertation, University of Massachusetts, Amherst.
- Diesing, Molly and Eloise Jelinek. 1993. Distributing Arguments. Ms., Cornell University and The University of Arizona.
- Dixon, R.M.W. 1979. Ergativity. *Language* 55:1, 59-139.
- Dowty, David R. 1979. *Word Meaning and Montague Grammar*. Reidel Publishing Co.
- Dowty, David. 1991. Thematic Proto-Roles and Argument Selection. *Language* 66.
- Enç, Mürvet. 1991. The Semantics of Specificity. *Linguistic Inquiry* 22:1, 1-25.
- Fodor, Janet Dean and Ivan A. Sag. 1982. Referential and Quantificational Indefinites. *Linguistics and Philosophy* 5:355-398.
- Fortescue, M.D. 1980. Affix Ordering in West Greenlandic Derivational Processes. *International Journal of American Linguistics* 46:4, 259-278.
- Grimshaw, Jane and Ralf-Armin Mester. 1985. Complex Verb Formation in Eskimo. *Natural Language and Linguistic Theory* 3, 1-19.
- Grimshaw, Jane. 1990. *Argument Structure*. Cambridge, MA: MIT Press.
- Gropen, Jess, Steven Pinker & Michelle Hollander, Richard Goldberg. 1991. Affectedness and Direct Objects: The Role of Lexical Semantics in the Acquisition of Verb Argument Structure. In B. Levin and S. Pinker (eds.) *Lexical and Conceptual Semantics*. Blackwell.
- Hale, Ken and Samuel Jay Keyser. 1992. The Syntactic Character of Thematic Structure. In I.M. Roca (ed.) *Thematic Structure: Its Role in Grammar*. Dordrecht: Foris.
- Harris, Alice C. 1982. Georgian and the Unaccusative Hypothesis. *Language* 58:2, 290-306.
- Heath, Jeffrey. 1976. Antipassivization: A Functional Typology. *Proceedings of the Berkeley Linguistics Society* 2.
- Heim, Irene. 1982. *The Semantics of Definite and Indefinite Noun Phrases*. New York: Garland Publishing.
- Hill, Jane. 1969. Volitional and Non-Volitional Verbs in Cupeño. *Proceedings of the Chicago Linguistic Society* 5.
- Hoekstra, Teun and René Mulder. 1990. Unergatives as Copular Verbs: Locational and Existential Predication. *The Linguistic Review* 7:1-79.

- Hoop, Helen de. 1989. Case Assignment and Generalized Quantifiers. *Proceedings of the North East Linguistics Society* 19.
- Hoop, Helen de. 1992. *Case Configuration and Noun Phrase Interpretation*. Doctoral dissertation. Rijksuniversiteit Groningen.
- Jacobson, Steven A. 1984. *Yup'ik Eskimo Dictionary*. Alaska Native Language Center, University of Alaska.
- Jacobson, Steven A. 1993. *A Practical Grammar of the Central Alaskan Yup'ik Eskimo Language*. Unpublished ms, Alaska Native Language Center and Program, University of Alaska, Fairbanks.
- Jelinek, Eloise and Richard A. Demers. 1983. The Agent Hierarchy and Voice in Some Coast Salish Languages. *International Journal of American Linguistics* 49:2, 167-185.
- Johns, Alana. 1992. Deriving Ergativity. *Linguistic Inquiry* 23:1, 57-87.
- Kalmár, I. 1979. The Antipassive and Grammatical Relations in Eskimo. In Franz Plank (ed.) *Ergativity*. New York: Academic Press.
- Kamp, J.A.W. 1981. A Theory of Truth and Semantic Representation. In J. Groenendijk, T. Janssen and M. Stokhof (eds.). *Formal Methods in the Study of Language* Amsterdam: Mathematical Centre, 277-321.
- Laka, Itziar. 1993. Unergatives that Assign Ergative; Unaccusatives that Assign Accusative. *MIT Working Papers in Linguistics* 18, 149-172.
- Legendre, Géraldine and David S. Rood. 1992. On the Interaction of Grammar Components in Lakhóta: Evidence from Split Intransitivity. *Proceedings of the Berkeley Linguistics Society* 18.
- Levin, Beth and Malka Rappaport. 1986a. What to Do With theta-Roles. *Lexicon Working Papers* 11, MIT.
- Levin, Beth and Malka Rappaport Hovav. 1993. The Lexical Semantics of Verbs of Motion: the Perspective from Unaccusativity. In Reuland and Abraham (eds.). *Knowledge and Language* vol.II. Kluwer.
- Levin, Juliette and Diane Massam. 1985. Surface Ergativity: Case/Theta Relations Reexamined. NELS 15
- Mahajan, Anoop. 1991. Clitic Doubling, Object Agreement and Specificity. *Proceedings of the North East Linguistics Society* 21.
- Mahajan, Anoop. 1992. The Specificity Condition and the CED. *Linguistic Inquiry* 23, 510-516.
- McLendon, Sally. 1978. Ergativity, Case, and Transitivity in Eastern Pomo. *International Journal of American Linguistics* 44:1, 1-9.
- Merlan, Francesca. 1985. Split Intransitivity: Functional Oppositions in Intransitive Inflection. In J. Nichols and A. Woodbury (eds.). *Grammar Inside and Outside the Clause*. Cambridge: Cambridge University Press.
- Mey, Jacob. 1971. Reflexives in Eskimo. *International Journal of American Linguistics* 32:1, 1-5.
- Milsark, Gary. 1977. Toward an Explanation of Certain Peculiarities of the Existential Construction in English. *Linguistic Analysis* 3:1, 1-30.
- Ouhalla, Jamal. 1990. Sentential Negation, Relativized Minimality and the Aspectual Status of Auxiliaries. *The Linguistic Review* 7, 183-231.
- Partee, Barbara H. 1987. Noun Phrase Interpretation and Type-Shifting Principles. In J. Groenendijk, D. de Jongh and M. Stokhof (eds.). *Studies in Discourse Representation Theory and the Theory of Generalized Quantifiers*. Dordrecht: Foris, 115-143.
- Perlmutter, David. 1978. Impersonal Passives and the Unaccusative Hypothesis. *Proceedings of the Berkeley Linguistics Society* 4.
- Pesetsky, David. 1987. Wh-in-Situ: Movement and Unselective Binding. In E. Reuland and A. ter Meulen (eds.). *The Representation of (In)definiteness*. Cambridge, MA: MIT Press.
- Qian, Che. 1992. A Preliminary Discussion of Subject Marking (byed-sgra) in Lhasa Tibetan. *Linguistics of the Tibeto-Burman Area* 15:1, 53-63.
- Ramchand, Gillian Catronia. 1992. Aspect Phrase in Modern Scottish Gaelic. Ms.

- Reed, Irene, Osahito Miyaoka, Steven Jacobson, Paschal Afcan, Michael Krauss. 1977. *Yup'ik Eskimo Grammar*. Alaska Native Language Center and the Yup'ik Language Workshop, University of Alaska.
- Runner, Jeffrey T. 1993. Quantificational Objects and Agr-O. *Proceedings of SCILS, MIT Working Papers in Linguistics*.
- Sadock, Jerrold M. 1980. Noun Incorporation in Greenlandic: A Case of Syntactic Word Formation. *Language* 56:2.
- Sadock, Jerrold M. 1985. Autolexical Syntax: A Proposal for the Treatment of Noun Incorporation and Similar Phenomena. *Natural Language and Linguistic Theory* 3, 379-439.
- Silverstein, Michael. 1976. Hierarchy of Features and Ergativity. In R.M.W. Dixon (ed.). *Grammatical Categories in Australian Languages*. Humanities Press.
- Smith, Lawrence R. 1982. An Analysis of Affixal Verb Derivation and Complementation in Labrador Inuttut. *Linguistic Analysis* 10:2, 161-189.
- Speas, Margaret. 1990. *Phrase Structure in Natural Language*. Dordrecht: Kluwer Academic Publishers.
- Suñer, Margarita. 1988. The Role of Agreement in Clitic-doubled Constructions. *Natural Language and Linguistic Theory* 6, 391-434.
- Tarpen, Marie-Lucie. 1982. Ergative and Accusative: A Single Representation of Grammatical Relations With Evidence From Nisgha. *Working Papers of the Linguistics Circle of the University of Victoria (WPLC)* 2:1, 50-106.
- Tenny, Carol. 1992. The Aspectual Interface Hypothesis. In I. Sag and A. Szabolcsi (eds.). *Lexical Matters*. CLSI Lecture Notes No. 24.
- Tournadre, Nicolas. 1991. The Rhetorical Use of the Tibetan Ergative. *Linguistics of the Tibeto-Burman Area* 14:1, 93-107.
- Urbanczyk, Suzanne. 1993. English Passive and Nisgha Antipassive: One Voice. Ms., University of Massachusetts, Amherst.
- Van Valin, Robert D., Jr. 1977. Ergativity and the Universality of Subjects. *Proceedings of the Chicago Linguistic Society* 13
- Van Valin, Robert D., Jr. 1985. Case Marking and the Structure of the Lakhota Clause. In J. Nichols and A. Woodbury (eds.). *Grammar Inside and Outside the Clause*. Cambridge: Cambridge University Press.
- Van Valin, Robert D., Jr. 1990. Semantic Parameters of Split Intransitivity. *Language* 66.
- Verkuyl, Henk J. 1993. *A Theory of Aspectuality*. Cambridge: Cambridge University Press.
- Woodbury, Anthony C. 1977a. Greenlandic Eskimo, Ergativity, and Relational Grammar. In P. Cole and J. Sadock (eds.). *Grammatical Relations*. Syntax and Semantics 8. New York: Academic Press.
- Woodbury, Anthony C. 1977b. The Greenlandic Verbal Suffix [-ut-]: Interactions of Linguistic Form and Grammatical Function. *Proceedings of the Berkeley Linguistics Society* 3.
- Woodbury, Anthony C. 1981. *Study of the Chevak Dialect of Central Yup'ik Eskimo*. Doctoral dissertation. University of California, Berkeley.
- Woodbury, Anthony C. 1985. Marginal Agent Clauses in Central Alaskan Yupik Eskimo: Internal and External Syntax. *Proceedings of the Chicago Linguistic Society* 21.
- Woodbury, Anthony C. and Jerrold M. Sadock. 1986. Affixal Verbs in Syntax: A Reply to Grimshaw and Mester. *Natural Language and Linguistic Theory* 4, 229-244.
- Woolford, Ellen. 1993. Four-Way Case Systems: Ergative, Nominative, Objective and Accusative. Ms., University of Massachusetts, Amherst.

Department of Linguistics
1401 Marie Mount Hall
University of Maryland
College Park, MD 20742

lbenua@deans.umd.edu